

A photograph of a modern building's entrance. The entrance features a glass door system with a white frame. An elephant is standing in the doorway, looking out. The building has a wooden deck and a balcony above. The background shows a scenic view of a lake and snow-capped mountains under a blue sky.

FFT FLEX Green
FFT FLEX Green 2D

Mounting instructions

Contents

	Page
1. General	3
2. Safety	4
3. Product description.....	5
4. Installation.....	7
4.1 Wall installation	8
4.1.1 Cutting the channel for the optional floor guide	9
4.1.2 Installing the wall mounting profiles	10
4.1.3 Installing the drive unit	12
4.2 Corridor installation	14
4.2.1 Cutting the channel for the optional floor guide	15
4.2.2 Installing the wall mounting profile.....	16
4.2.3 Installing the drive unit	18
4.3 Mounting the floor guide rail (optional)	20
4.4 Checking and adjusting the locking (optional)	20
4.5 Installing the manual release (optional).....	20
4.6 Installing the MDU	23
4.7 Preparing the door panels.....	23
4.8 Installing the door panels	24
4.9 Aligning the closing edge.....	26
4.10 Fixing the floor bearings.....	27
4.11 Tightening the wall mounting profiles	27
4.12 Cover on the wall mounting profile for a 1-panel wall mounting	27
4.13 Mounting the covers to the wall mounting profiles.....	27
4.14 Mounting the cover caps	28
4.15 Preparing the rods	29
4.16 Mounting the rods	29
4.17 Mounting the end stop	31
4.18 Mounting the cable duct	31
4.19 Mounting the cable holder.....	32
4.20 Mounting the battery	32
4.21 Mounting the cover for the pivot bearing	32
4.22 Mounting the inner lining	33
4.23 Mounting the rail profile.....	34
4.24 Mounting components.....	34
4.25 Wiring inside the drive unit	34
4.26 Mounting the cover angles (Installing the door in the corridor).....	35
4.27 Mounting the fanlight (optional)	36
5. Commissioning	38
6. Error display.....	40
7. Troubleshooting	41

APPENDIX



	Page
Control unit basic module.....	42
Control unit 2D module (FST module).....	43
Control unit functional module.....	44
Connection diagram night-bank opening via key switch KT 3 or card reader.....	45
Connection diagram battery.....	45
Connection diagram EMERGENCY STOP button (not for escape route systems).....	46
Connection diagram mechanical program switch.....	46
Connection diagram program switch EPS-S.....	47
Connection diagram detector.....	47
Connection diagram locking with response contact.....	48
Connection diagram service display.....	48
Connection diagram EMERGENCY STOP input (not for escape route systems).....	49
Connection diagram battery (FST module).....	49
Connection diagram mechanical program switch (FST module).....	50
Connection diagram EPS-FST (FST module).....	50
Connection diagram locking with response contact (FST module).....	51
Connection diagram airlock.....	51
Connection diagram airlock with pulse relaying.....	52
Connection diagram time airlock.....	52
Connection diagram panic lock.....	53

1. General

Please retain the documents and forward them to the new owner in case the system is passed on.

The illustrations in these instructions are primarily concerned with the wall mounting.
In case the installation differs, these differences are shown based on the corridor installation illustration.

Symbols used in this manual

-  **NOTE** A note points to important information that will facilitate your work.
-  **REMARK** A remark warns you against possible damage to the device and explains how it can be prevented.
-  **WARNING** Indicates risks that may lead to physical injury or death.

 **Unless indicated otherwise all measurements are shown in mm.**

"Translation of the original manual"

2. Safety

This documentation contains important instructions for the installation and safe operation. Read these instructions before you begin with the installation.

In order ensure your safety please follow all the enclosed instructions.

An incorrect installation can lead to serious injuries.

The use of control elements, settings or procedures that are not described in this document may result in electrical shocks, risks due to electrical voltages/currents and/or risks due to mechanical processes.

Intended use

FFT and **FFT-F** are folding doors for passenger traffic.

They may be used only in dry rooms.

The **FFT** may not be used along escape and emergency routes.

The **FFT-F** may be used for escape and emergency routes. The cable length for external components may not exceed 30 m.

Limitation of liability

FFT and **FFT-F** may be used only for their intended purpose. Unauthorized modifications to the door system will exclude any liability by **DORMA Deutschland GmbH** for the resulting damage. We will not be liable for the use of accessories that are not approved by **DORMA**.

Risk assessment by the installer

The installer, i.e. the person carrying out the installation and the customer/operator must together carry out an individual risk assessment when planning the system.

Please refer to the "Risk assessment" form available to support the procedure. They are available under the **PRODUCTS** tab on our website www.dorma.de.

Special safeguard requirements for people in need of protection

Should the risk assessment indicate that the door panels could hit a person resulting in an injury, additional sensors are to be installed in order to rule out the risk.

This is to be considered especially if children, seniors or handicapped persons use the door system.

Standards, laws, guidelines and regulations

The latest version of the generally applicable and country-specific standards, laws, guidelines and regulations is to be complied with.

EMERGENCY stop button (optional)

The EMERGENCY STOP button may not be used for escape route systems.

In case of a hazardous situation or in order to prevent danger, the EMERGENCY STOP button will put the door system quickly into a safe state.

The EMERGENCY STOP switch features a red operating element on a yellow background.

It is located near the door system.

Safety instructions



Work on electrical equipment may only be performed by properly qualified specialists.



Never insert a metal object into the openings of the door system. Otherwise, there will be the risk of an electrical shock.



Safety glass must be used for glass door panels.

Residual risk

Depending on the structural conditions, the type of door and protection, it is not possible to rule out residual risks (e. g. slight bruising, limited impact and the risk to unsupervised children).

Instruction

After a successful adjustment, commissioning and functional test of the door system, the operating manual is to be handed over to the owner who is to be instructed in the operation and maintenance of the door system.

3. Product description

FFT FLEX Green (in the text **FFT**) and FFT FLEX Green-2D (in the text **FFT-F**) are folding doors. The door panels consist of 2 half panels in each case. When opened, they are moved to the side by a folding movement. This minimizes the required space in favor of the passage width.

There are 4 installation options available: Single-panel and double panel doors each for wall mounting and corridor installation.

Scope of delivery

Since the FFT will always be prepackaged according to the order, please refer to the parts list on the delivery note to check the shipment.

Technical data

Power supply:	230 V/50-60 Hz
Protection class:	IP 20
Fuse protection provided by the customer:	10 A
Operating noise:	< 55 dB (A)
Temperature range:	-15°C to +60°C
Maximum passage width	1- panel: 1200 mm 2-panel: 2400 mm
Weight of door panel	max. 90 kg

Program switch

You can select 5 functions via the program switch. The switch is located near the door system.

Function	Meaning
OFF ← →	The system does not open automatically. In case of systems with a locking device, the door is mechanically locked.
AUTOMATIC ↑↓	The door will be automatically opened once an activator has been activated. The door will close again once the set hold-open time has expired.
PERMANENT OPEN ← →	The door will be automatically opened and stays open as long as this function is activated.
EXIT ONLY ↑↑	The door will be automatically opened only after the inside activator has been enabled. The door will close again once the set hold-open time has expired.
PARTIAL OPEN ↑↓↑↓	The door will be opened automatically up to the set partial passage width once an activator has been enabled. The door will close again once the set hold-open time has expired.

Error LED (only for escape route systems)

The fault LED is located at the program switch. It will light in case of an error that interferes with the escape route operation. The door will stay open in the "Open position".

Operating elements on the control unit

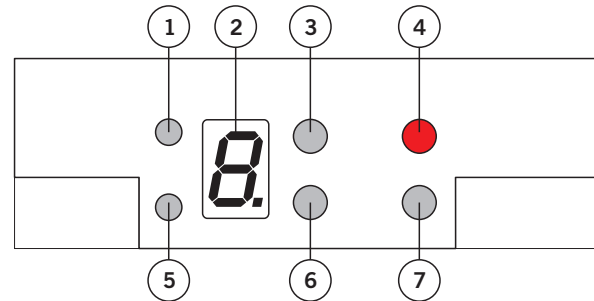

- 1 LED 1 (status of the safety sensor system 1)
- 2 7-segment display
- 3 Drucktaster (+)
- 4 Servicetaste
- 5 LED 2 (status of the safety sensor system 2)
- 6 Drucktaster (-)
- 7 Select key (menu control)

Floor guide (optional)

The floor guide helps to stabilize large doors during their movement.

Locking device (optional)

The locking device is used to secure the door against an unintended opening.

Manual lock release (optional)

The manual lock release allows you to open the locked door during a power failure.

Fanlight (optional)

The fanlight can be used for doors with a corridor installation.

Night/bank activator (optional)

The night/bank activator is used to open the disabled door system from the outside. Depending on the model, it can be operated using a key or electronically (e. g. with a credit card or EC card). It is located on the outside near the door system.

Service display (optional)

The display will remind the operator that maintenance is to be carried out on the door system. The maintenance intervals can be set by the service technician. You can enter a time interval (month, e. g. every 6 months) and/or a load cycle interval (e. g. after 80000 load cycles).

Depending on the type of event, the service display will light up as follows:

- Load cycle interval has lapsed:
 - Display shows continuous light:
- Time interval has lapsed:
 - Display flashes (every 0.5 seconds).
- Time and load cycle intervals have lapsed:
 - Display shows 10 seconds of continuous light and flashes for 10 seconds.

The maintenance notification will be acknowledged by the service technician.

FFT FLEX GREEN / FFT FLEX GREEN 2D

Menu structure

Display during operation

 Display in case of an fault-free operation of the drive unit.

 Display in case of a faulty operation of the drive unit (display flashes).

Parameters display







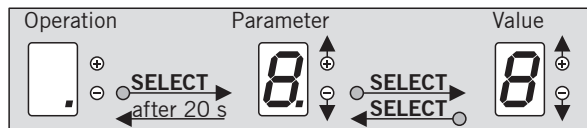





Menu for selecting the parameter to be checked or changed.

Value display

Displays the value that was selected earlier via the parameter display.













Parameter display

Parameter display	Value display
 Error message	0 - F
 Closing speed	0 - 8
 Opening speed	0 - d
 Hold-open time	0 - F
 Night/bank hold-open time	0 - F
 Battery emergency operation	0 - 3
 Type of locking	0 - 2
 Locking in program switch positions	0 - 3
 Parameter lock	0, 1
 Protocol UART 1	1, 2, 4, 8
 Reset maintenance	1
 Opening width	700 - 3000















Meaning of the display

 **Error message**
see page 28.











 **Closing speed**

 8 %/second
 12 %/second
 17 %/second
 21 %/second
 25 %/second
 30 %/second
 34 %/second
 38 %/second
 42 %/second

Opening speed

 7 %/second
 11 %/second
 16 %/second
 20 %/second
 24 %/second
 29 %/second
 33 %/second
 37 %/second
 41 %/second
 46 %/second
 50 %/second
 54 %/second
 59 %/second
 63 %/second





Hold-open time

 0 seconds
 1 seconds
 2 seconds
 5 seconds
 8 seconds
 10 seconds
 15 seconds
 20 seconds
 25 seconds
 30 seconds
 Setting via hand terminal



Hold-open time night/bank

see **hold-open time**





Battery emergency operation

 No battery operation
 Emergency closing
 Emergency opening
 Battery emergency operation

Type of locking

 No locking
 Bistable locking
 Bistable locking with response contact (closing contact)



Locking in program switch position

 OFF
 OFF and EXIT ONLY
 OFF, AUTOMATIC and PARTIAL OPEN
 Always in the CLOSED position

Parameter lock

 on
 OFF

Protocol UART 1

 Hand terminal
 Data logger
 TMS Soft

Opening width

see page 27

Setting the opening width on the control unit.

4. Installation

 **Protect the workspace against trespassing. Dropped parts or tools may result in injuries.**

The described procedure is only an example. Another procedure might be preferable due to structural or local conditions, available tools or other circumstances.

Requirements

A 230 V/50-60 Hz connection with a fuse protection of 10 A must be available at the place of installation.

Standard tightening torques

M 5 5 Nm
 M 6 9,5 Nm
 M 8 23 Nm
 M 10 46 Nm
 M 12 79 Nm

Required material

- Padwood in several thicknesses

Depending on the local conditions

- PU foam
- Compriband
- Silicon

Material to be provided on site (optional)

For the manual lock release (optional):

Profile half cylinder 10/60 according to EN 1303 / DIN18252
 or
 round half cylinder 10/62 according to VSSB standard 20200

For the hook-shaped dead bolt lock (optional):

short cylinder 21/21mm

For the floor lock (optional):

Lockable from the outside and inside
 Profile half cylinder 30.5/45.5 according to EN 1303 / DIN18252
 or
 lockable from the inside
 Profile half cylinder 9.8/26.5 according to EN 1303 / DIN18252

Required tools

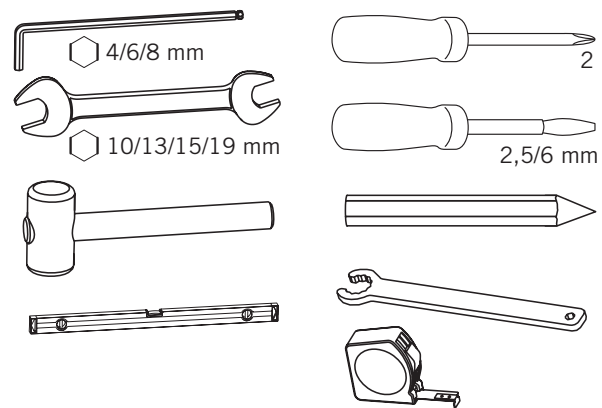

FFT FLEX GREEN / FFT FLEX GREEN 2D

4.1 Wall installation

Clear width	Double panel		Single panel	
	B1	B2	B1	B2
800	-	-	1028	906
900	1260	1100	1128	1006
1000	1360	1200	1228	1106
1100	1460	1300	1328	1206
1200	1560	1400	1428	1306
1300	1660	1500	-	-
1400	1760	1600	-	-
1500	1860	1700	-	-
1600	1960	1800	-	-
1700	2060	1900	-	-
1800	2160	2000	-	-
1900	2260	2100	-	-
2000	2360	2200	-	-
2100	2460	2300	-	-
2200	2560	2400	-	-
2300	2660	2500	-	-
2400	2760	2600	-	-
	B1 = LW + 360		B1 = LW + 228	
	B2 = LW + 200		B2 = LW + 106	

Depending on the structural situation, the clear width (LW) can be increased to up to 40 mm for each door panel.

Please follow the safety instructions according to the risk assessment.

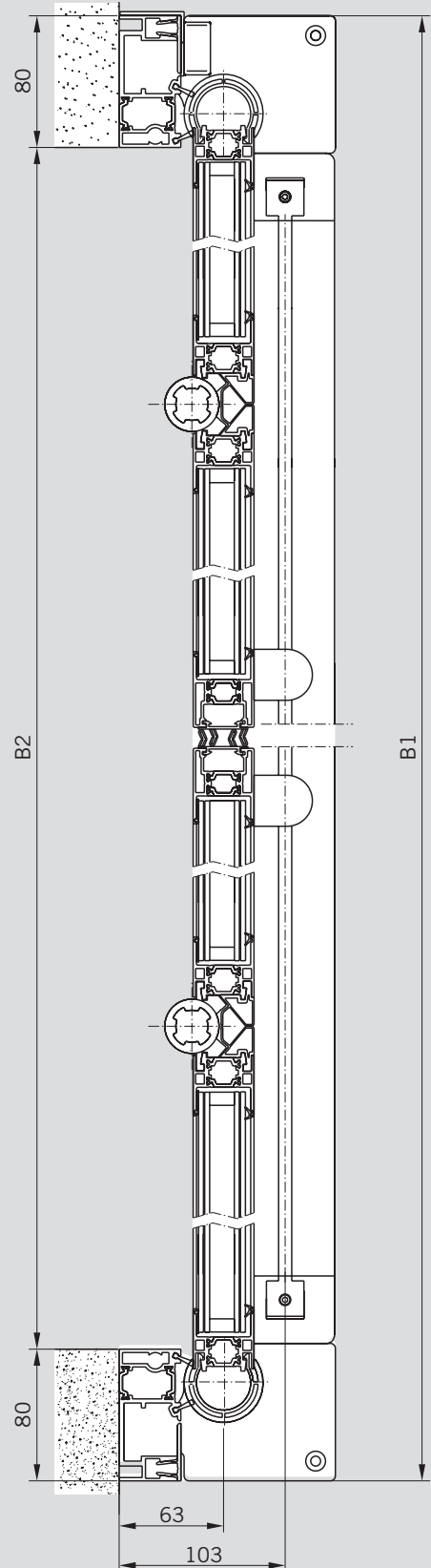
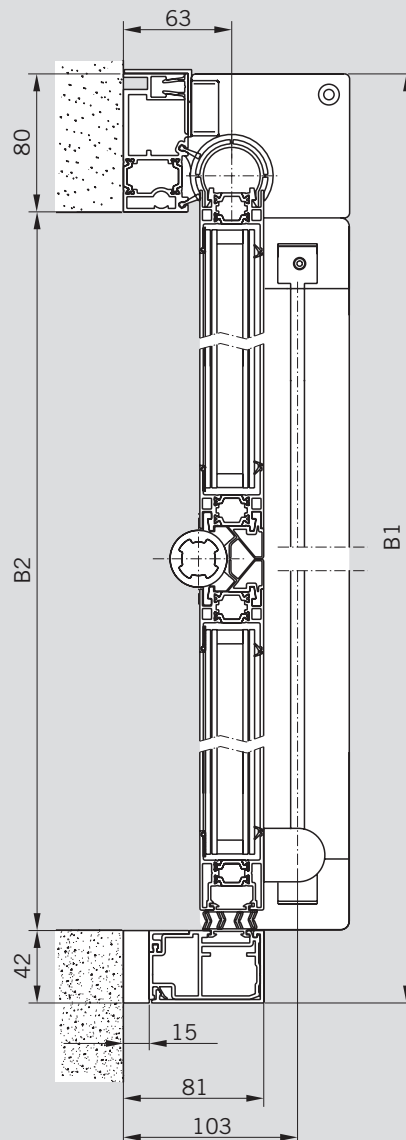

FFT FLEX GREEN / FFT FLEX GREEN 2D



The illustrations show the 2 panel wall installation but apply only to the single and double panel wall installation.

Steps that apply only to the 2 panel wall installation are marked with the picture number and **a**.

In addition, the symbol  is shown left at the top in picture.

Steps that apply only to the 2-panel wall installation are marked with the picture number and **b**.

In addition, the symbol  is shown left at the top in picture.

1. Mark the lower edge of the floor bearings on both sides of the corridor.
2. Determine the highest point within the clear width.
 -  Use a level.
3. Transfer this point to the wall.
 -  Should there be no finished floor, then transfer the intended height of the finished floor to the wall.

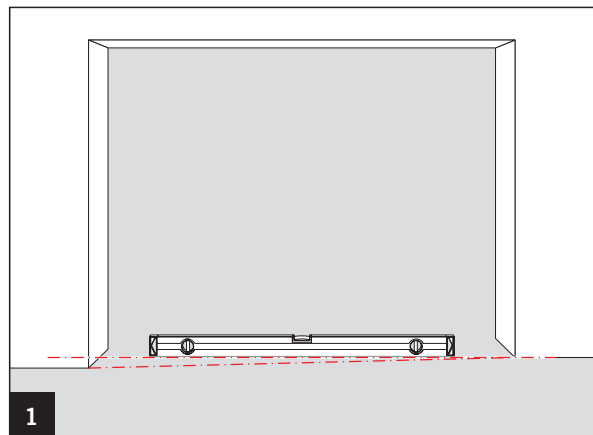
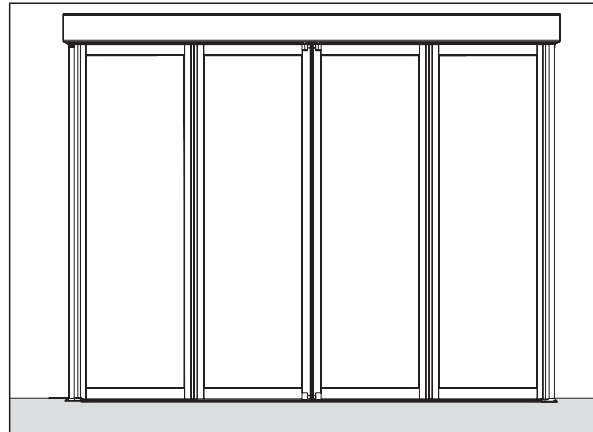

4.1.1 Cutting the channel for the optional floor guide

1. Cut the channel for the floor guide rail.
 -  In case the wall in the upper area extends into the room, you have to measure from this point.

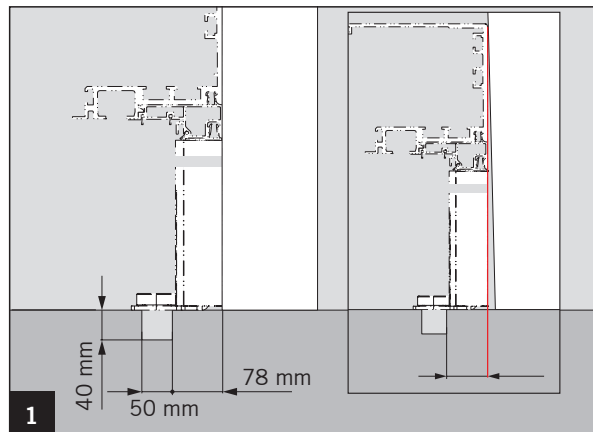

Placement of the channel in case of a double panel wall installation

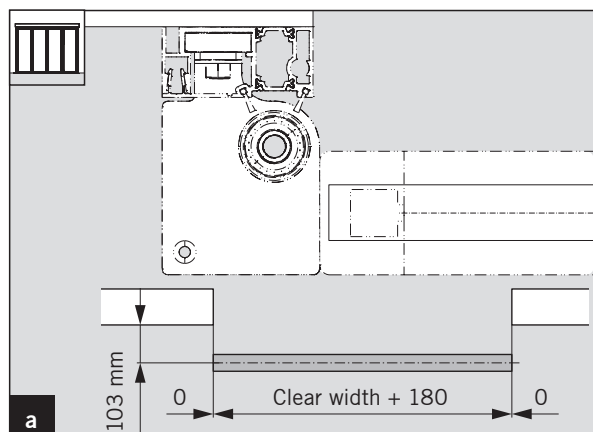

Placement of the channel in case of a singlepanel wall installation

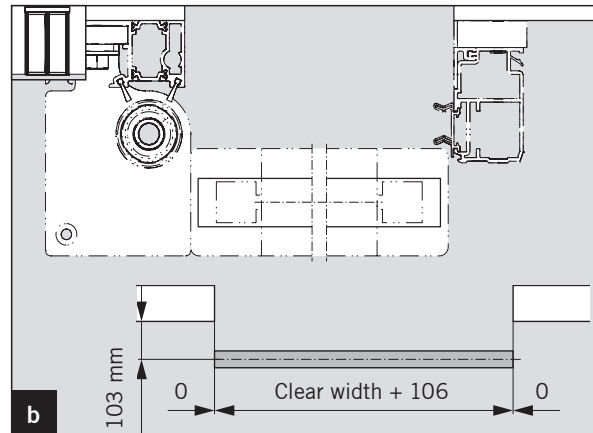

4.1.2 Installing the wall mounting profile

1. Look up the measurement **B1** (distance between the outer edges of the wall mounting profiles) in the enclosed documents.
2. Position the wall mounting profile to the left and right of the corridor.
 - ✎ Calculate the distance between the floor bearings using the formula **B1 - 119**.

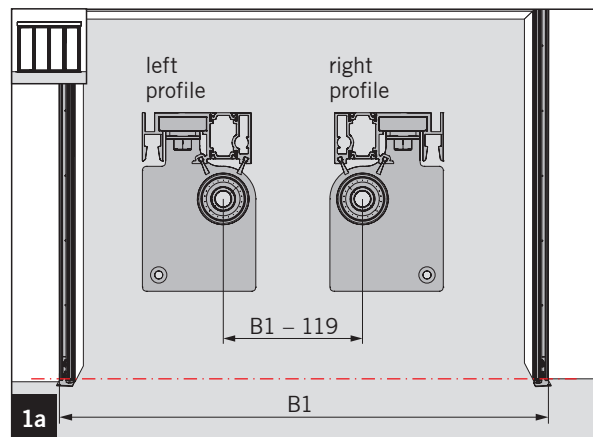

1. Look up the measurement **B1** (distance between the outer edges of the wall mounting profiles) in the enclosed documents.
2. Position the wall mounting profile to the left and right of the corridor.
 - ✎ Calculate the distance between the floor bearing and the wall mounting profile at the main closing edge using the formula **B1 - 101.5**.

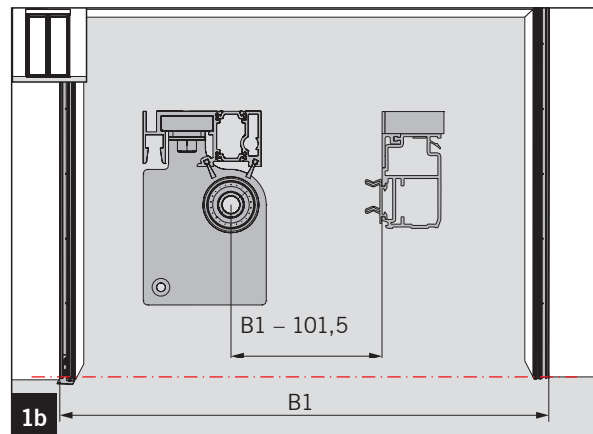

3. Place the lower edges of the floor bearings on the marking.
4. Carefully underpin the floor bearing (capable of bearing) with the provided shims as the entire door panel weight has to be permanently supported.
 - ✎ Should the floor not be finished, then firmly underpin the floor bearings. Make sure that the substructure does not extend beyond the floor bearings.

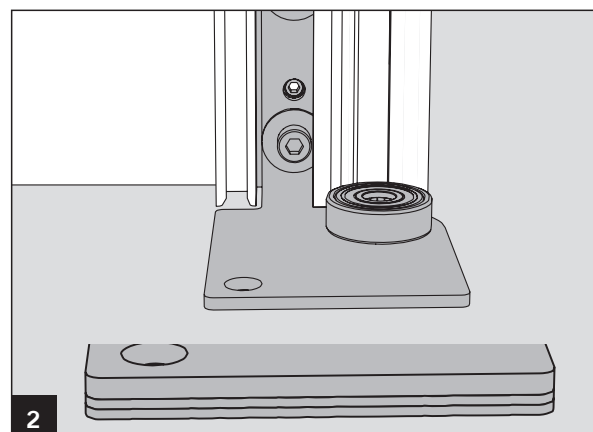

FFT FLEX GREEN / FFT FLEX GREEN 2D

5. Align the wall mounting profiles vertically and parallel in all directions.
They may not be misaligned to each other.
- ✎ Align the wall mounting profiles very accurately.
Any deviation will lead to additional work during the further installation.

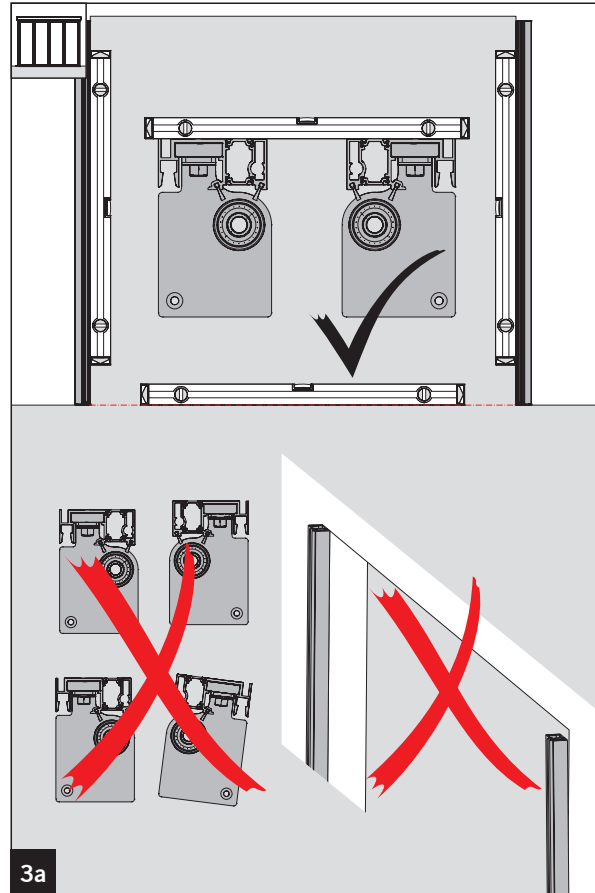

5. Align the wall mounting profiles vertically and parallel in all directions.
They may not be misaligned to each other.
- ✎ Align the wall mounting profiles very accurately.
Any deviation will lead to additional work during the further installation.

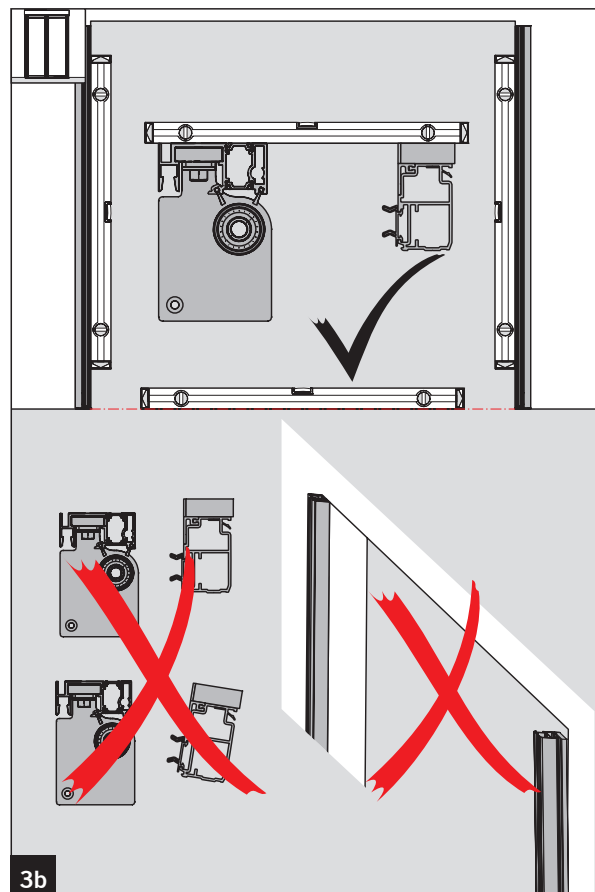

FFT FLEX GREEN / FFT FLEX GREEN 2D

6. Drill through the holes and fasten the wall mounting profiles with one screw each on the top and on the bottom.
 - 🔧 Protect the bearing against dirt.
 - 🔧 Support the resulting gaps with padwoods.
 - 🔧 For the fastening, use dowels and screws that match the background.
7. Seal the spaces with compriband to make it airtight. Seal the seam to the structure with a suitable sealing compound (e. g. silicon or acrylic).

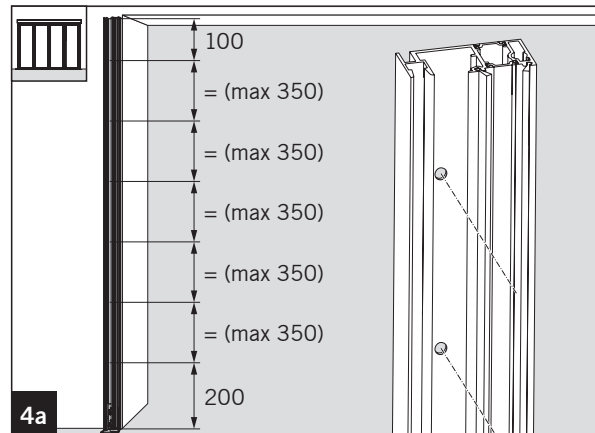

6. Drill through the holes and fasten the wall mounting profiles with one screw each on the top and on the bottom.
 - 🔧 Protect the bearing against dirt.
 - 🔧 Support the resulting gaps with padwoods.
 - 🔧 For the fastening, use dowels and screws that match the background.
7. Seal the spaces with compriband to make it airtight. Seal the seam to the structure with a suitable sealing compound (e. g. silicon or acrylic).

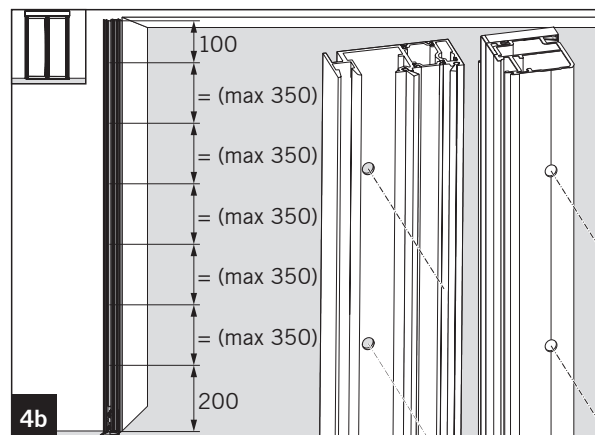

4.1.3 Installing the drive unit

1. Remove the inside panel.
 - 🔧 The inserted hinge profiles are used for a secure transport and have to be disposed of.
 - 🔧 Check the drive profile for transport damage and perpendicularity. Should the drive unit not be perpendicular, you will not be able to correctly mount the door.
2. Loosen the 4 screws on the base support of the MDU until the MDU can be taken out of the profile while the spacer is still connected to the screws.
3. Remove the MDU from the drive profile.

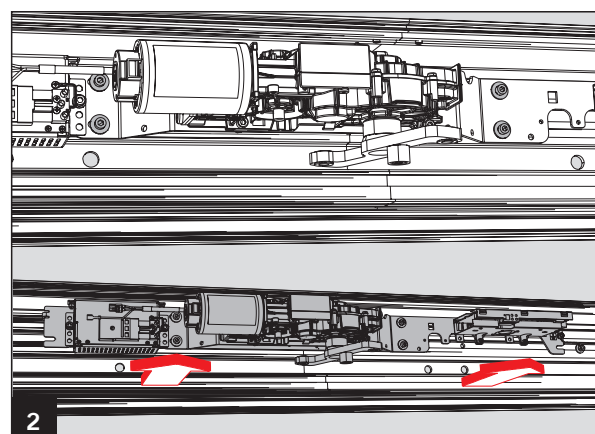
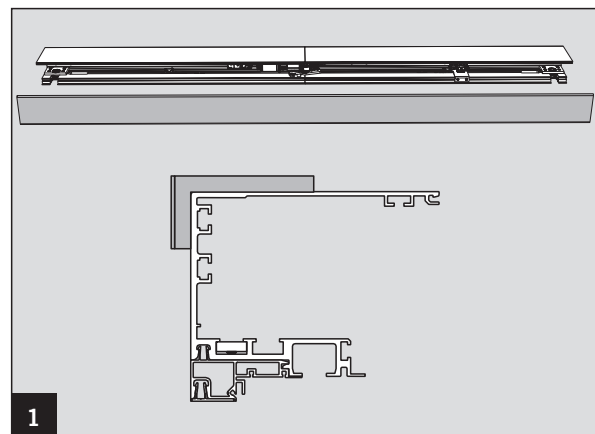

FFT FLEX GREEN / FFT FLEX GREEN 2D

4. Position the drive profile in the center on the two wall mounting profiles. The drive unit and wall mounting profile have to be flush on the outside. The clear passage height is achieved automatically.
 - ☞ Make sure to adhere to the clear passage height (LH) (LH +2 mm).
5. Mark **all** mounting holes.
6. Take down the drive unit and drill the holes.

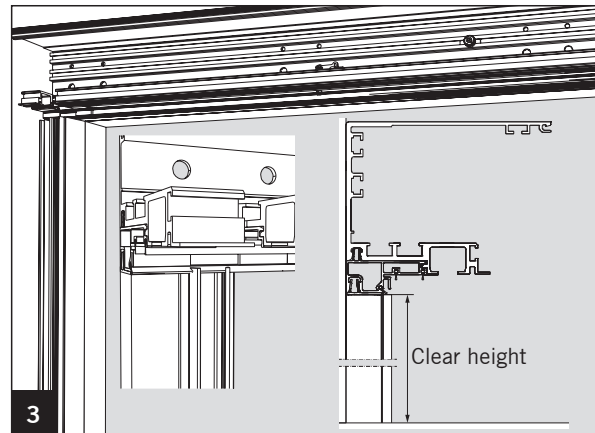

7. Place the drive profile again on the wall mounting profile and fasten it through the two outer and inner holes of the lower row.
8. Align the drive profile very accurately.
 - 🔗 Any deviation will lead to additional work during the course of the installation.
 - ☞ Make sure that the divided drive profile does not bend.
9. Tighten the drive profile through **all** holes
 - ☞ For the fastening, use dowels and screws that match the background.

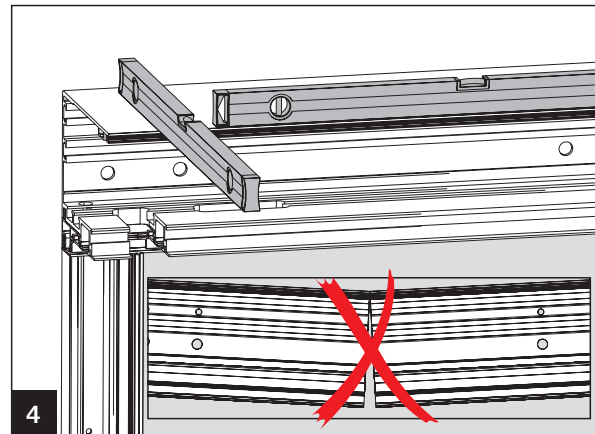

FFT FLEX GREEN / FFT FLEX GREEN 2D

4.2 Corridor installation

Clear width	Double panel	Single panel
	B	B
800	-	1060
900	1314	1160
1000	1414	1260
1100	1514	1360
1200	1614	1460
1300	1714	-
1400	1814	-
1500	1914	-
1600	2014	-
1700	2114	-
1800	2214	-
1900	2314	-
2000	2414	-
2100	2514	-
2200	2614	-
2300	2714	-
2400	2814	-
	$W = LW + 414$	$W = LW + 259$

Depending on the structural situation, the clear width (LW) can be increased to up to 40 mm for each door panel.

Please follow the safety instructions according to the risk assessment.

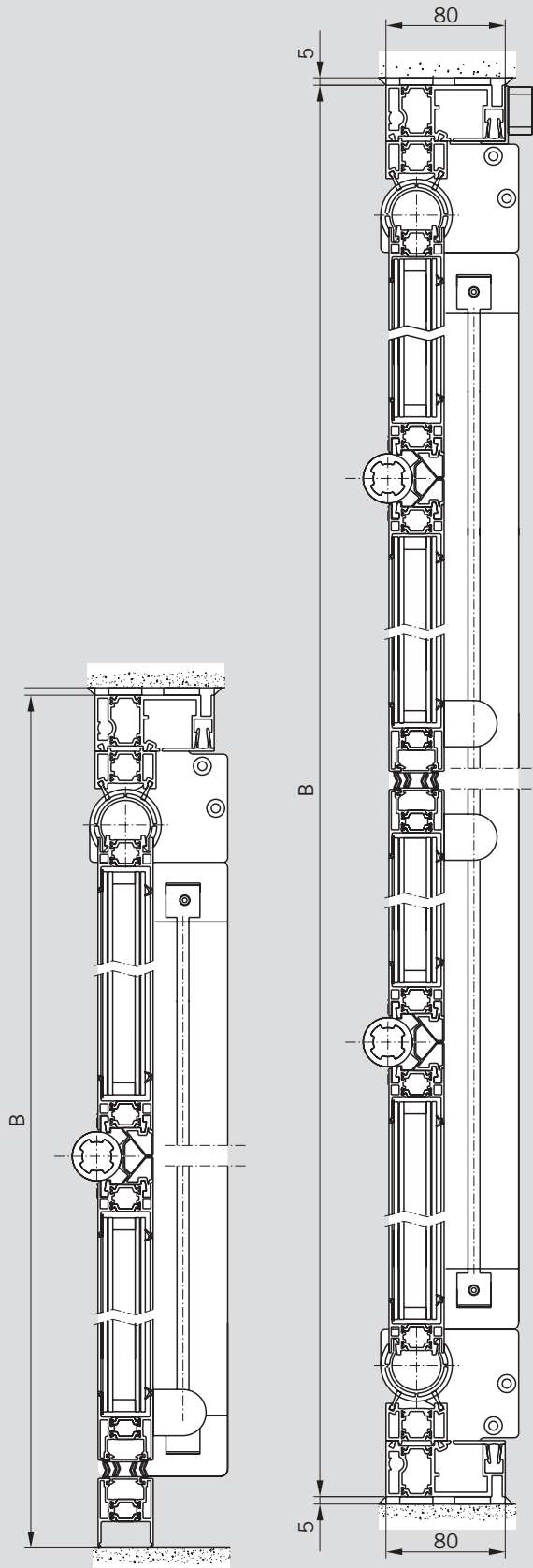

FFT FLEX GREEN / FFT FLEX GREEN 2D

The illustrations show the double panel corridor installation but apply both to the single and double panel corridor installation.

Steps that apply only to the double panel corridor installation are marked with the picture number and **a**.

In addition, the symbol  is shown left at the top in picture.

Steps that apply only to the single panel corridor installation are marked with the picture number and **b**.

In addition, the symbol  is shown left at the top in picture.

1. Mark the lower edge of the floor bearings on both sides of the corridor.
2. Determine the highest point within the clear width.
3. Transfer this point to the walls.
 -  Should there be no finished floor, then transfer the intended height of the finished floor to the wall.

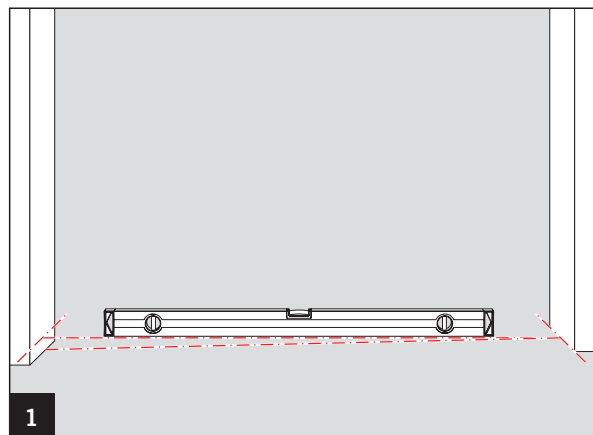
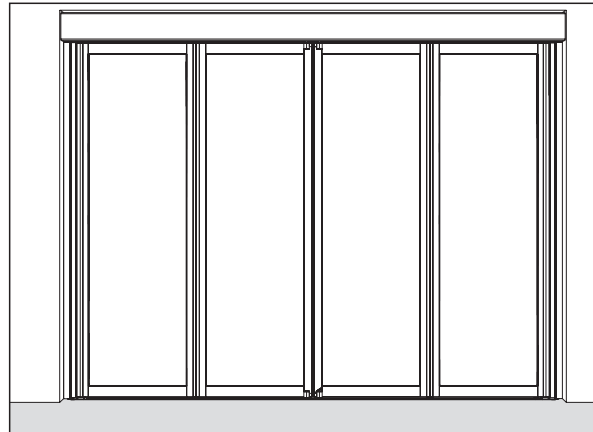

4.2.1 Cutting the channel for the optional floor guide

1. Cut the channel for the floor guide rail.

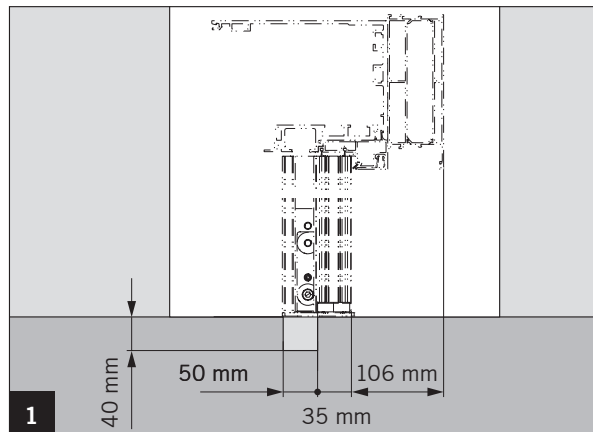

Placement of the channel for a double panel corridor installation

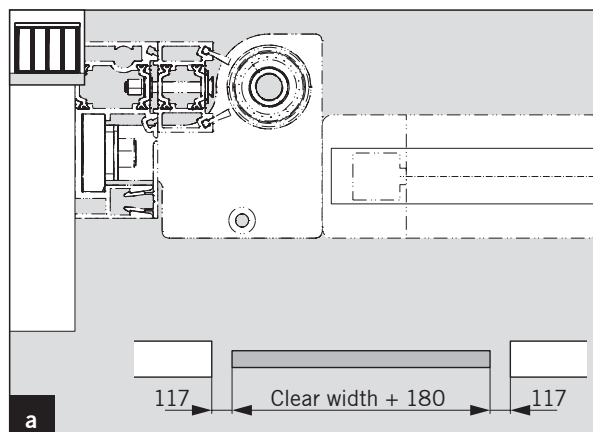

Placement of the channel for a double panel corridor installation

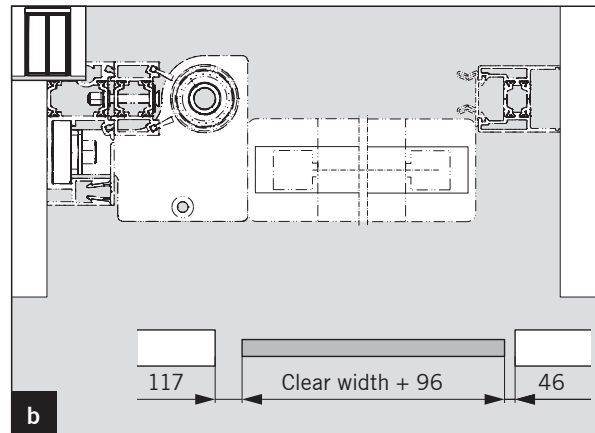

4.2.2 Installing the wall mounting profile

1. Look up the measurement **B** (distance between the outer edges of the wall mounting profiles) in the enclosed documents.
2. Position the wall mounting profile to the left and right of the corridor.
 - ✎ Calculate the distance between the floor bearings using the formula **B - 176**.

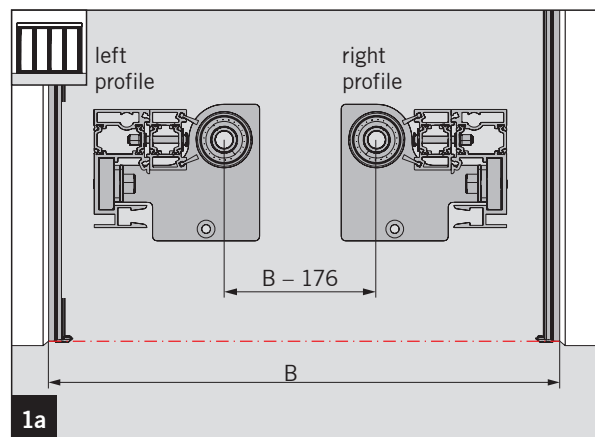

1. Remove the center seal from the wall mounting profile.
2. Look up the measurement **B** (distance between the outer edges of the wall mounting profiles) in the enclosed documents.
3. Position the wall mounting profile to the left and right of the corridor.
 - ✎ Calculate the distance between the floor bearings using the formula **B - 134**.

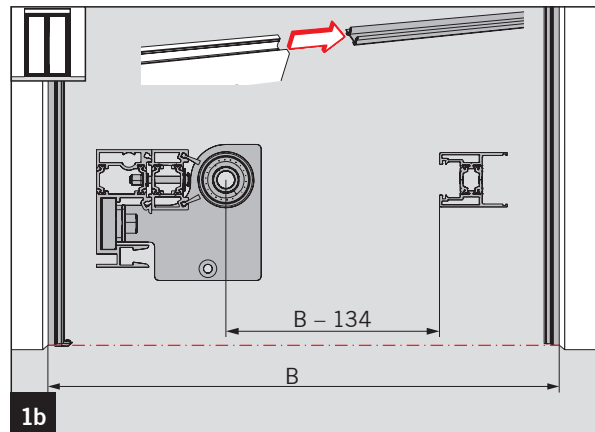

4. Place the lower edges of the floor bearings on the marking.
5. Carefully underpin the floor bearing (capable of bearing) with the provided shims as the entire door panel weight has to be permanently supported.
 - ✎ Should the floor not be finished, then firmly underpin the floor bearings. Make sure that the substructure does not extend beyond the floor bearings.

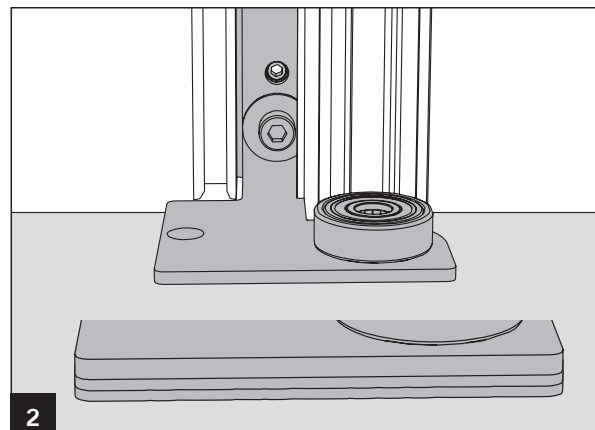

FFT FLEX GREEN / FFT FLEX GREEN 2D

- Align the wall mounting profiles vertically and parallel in all directions.
They may not be misaligned to each other.
- Align the wall mounting profiles very accurately.
Any deviation will lead to additional work during the course of the installation.

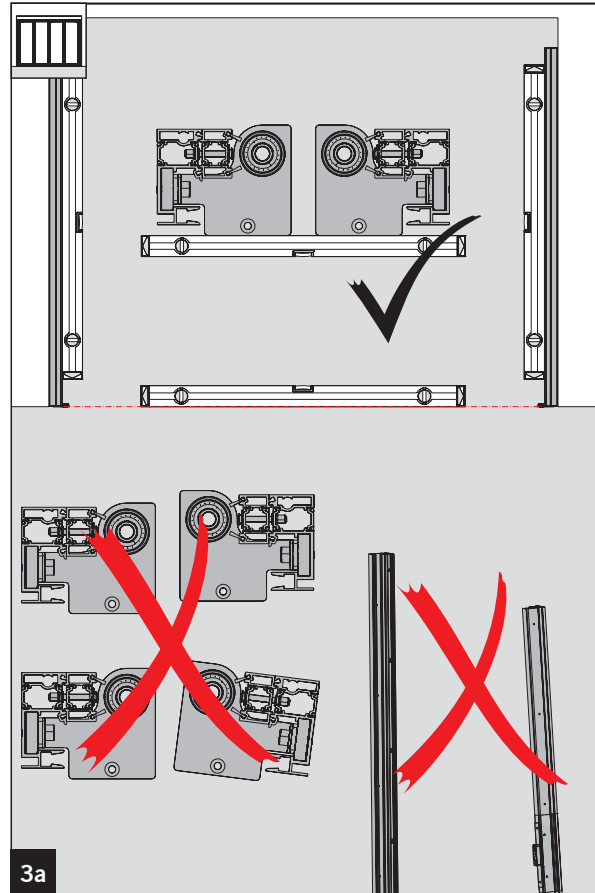

- Align the wall mounting profiles vertically and parallel in all directions.
They may not be misaligned to each other.
- Align the wall mounting profiles very accurately.
Any deviation will lead to additional work during the course of the installation.

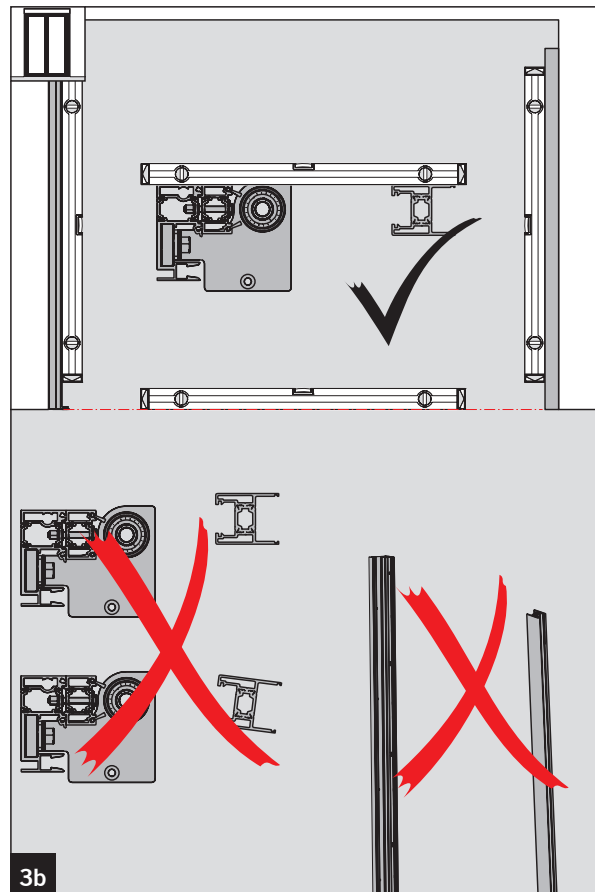

FFT FLEX GREEN / FFT FLEX GREEN 2D

7. Drill through the holes and fasten the wall mounting profiles with one screw each on the top and on the bottom.
 - 🔧 Protect the bearing against dirt.
 - 🔧 Support the resulting gaps with padwoods.
 - 🔧 For the fastening, use dowels and screws that match the background.
8. Seal the spaces with compriband to make it airtight. Seal the seam to the structure with a suitable sealing compound (e. g. silicon or acrylic).

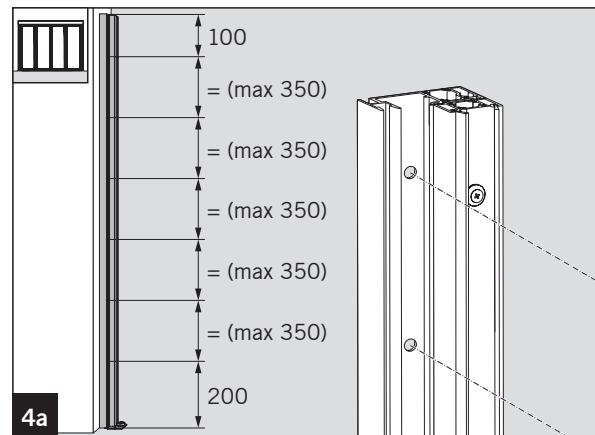

7. Transfer the position of the holes in the wall mounting profile to the center seal and drill it with $\varnothing 10$ mm.
8. Insert the center seal into the wall mounting profile.

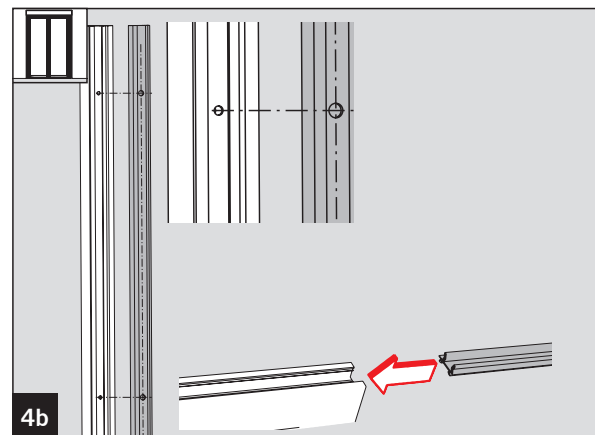

9. Drill through the holes and fasten the wall mounting profiles with one screw each on the top and on the bottom.
 - 🔧 Protect the bearing against dirt.
 - 🔧 Support the resulting gaps with padwoods.
 - 🔧 For the fastening, use dowels and screws that match the background.
10. Seal the spaces with compriband to make it airtight. Seal the seam to the structure with a suitable sealing compound (e. g. silicon or acrylic).

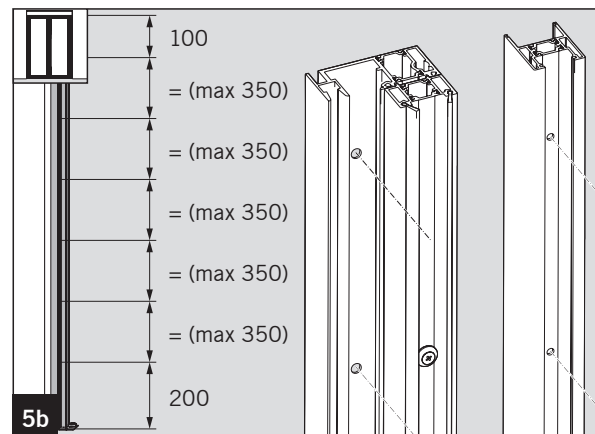

4.2.3 Installing the drive unit

1. Remove the inside panel.
 - 🔧 The inserted hinge profiles are used for a secure transport and have to be disposed of.
 - 🔧 Check the drive profile for transport damage and perpendicularity. Should the drive unit not be perpendicular, you will not be able to correctly mount the door.

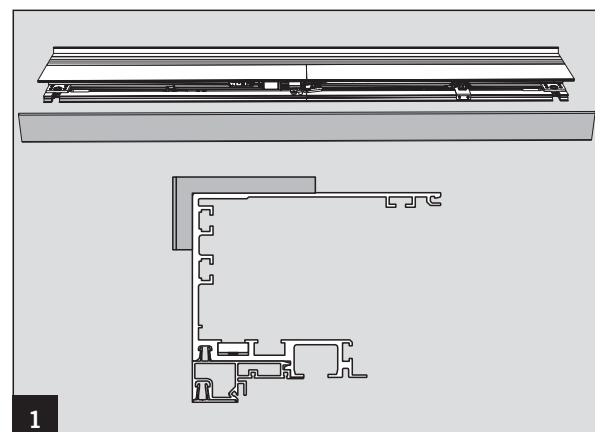

FFT FLEX GREEN / FFT FLEX GREEN 2D

2. Loosen the 4 screws on the base support of the MDU until the MDU can be taken out of the profile while the spacer is still connected to the screws.
3. Remove the MDU from the drive profile.

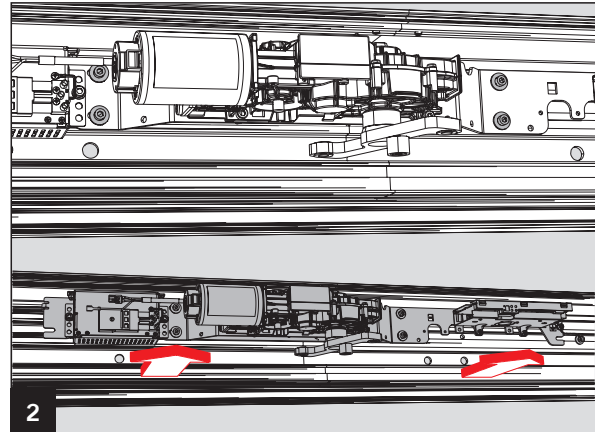

4. Position the drive unit in the center of the two wall mounting profiles. The drive unit and wall mounting profile have to be flush on the outside. The drive unit with the insulating profile must rest against the wall mounting profile. The clear passage height is achieved automatically.

☞ Make sure to adhere to the clear passage height (LH) (LH +2 mm).

5. Mark all mounting holes.
6. Take down the drive unit and drill the holes.

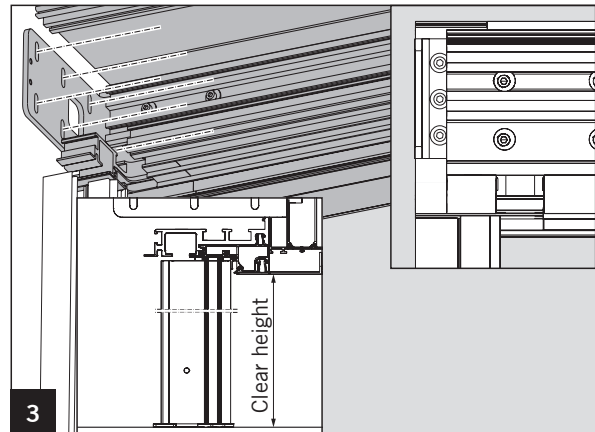

7. Place the drive again on the wall mounting profile and screw it through all holes to the wall.

8. Align the drive profile in all directions vertically and horizontally very accurately.

☞ Any deviation will lead to additional work during the course of the installation.

9. Tighten the drive profile through all holes.

☞ For the fastening, use dowels and screws that match the background.

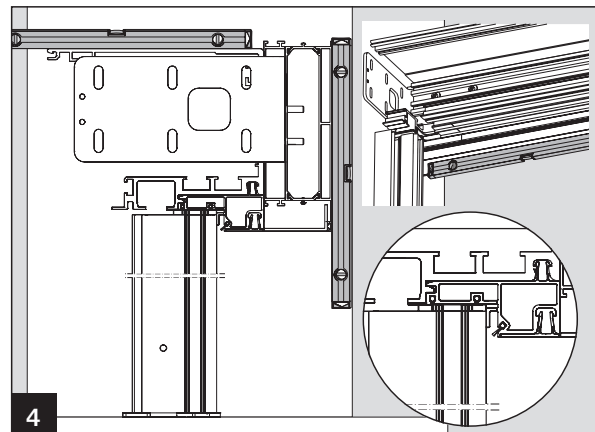

For systems without fanlight

1. Fill the hollow space above the drive unit with a suitable insulating material (e. g. PU foam).

FFT FLEX GREEN / FFT FLEX GREEN 2D

4.3 Mounting the floor guide rail (optional)

1. Mount the floor guide rail according to the enclosed instructions.

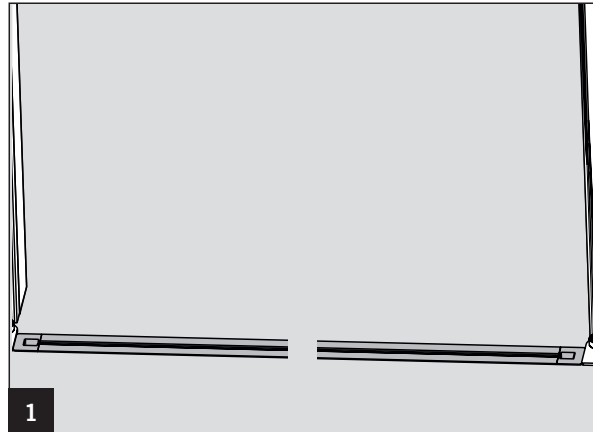

4.4 Checking and adjusting the locking device (optional)

1. Set the locking device into the OPEN position.
2. Check whether the locking bolts on the bottom of the drive unit end with the guide sleeves.
3. Should this not be the case, then loosen the nuts holding the locking device and align the bolts by moving the locking device.
4. Retighten the nuts.

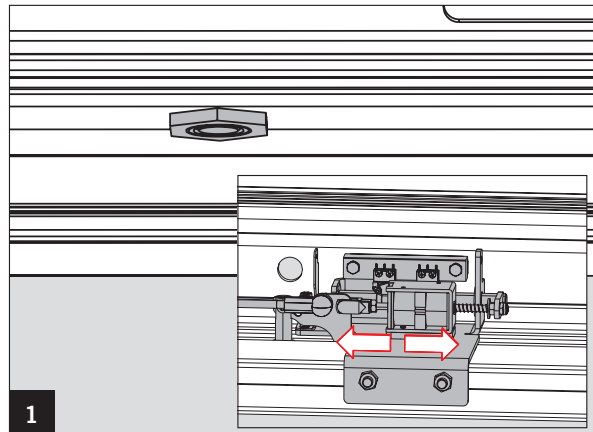

4.5 Mounting the manual lock release (optional)

1. Remove the cover from the manual lock release.

 The figure shows the manual lock release for the 2-panel wall installation. Use the same procedure for the corridor installation.

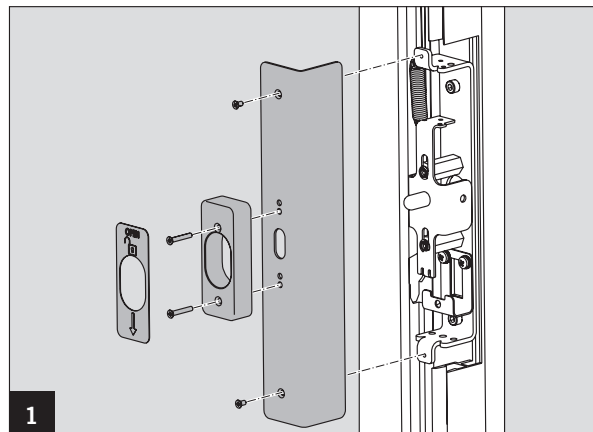

2. Slip the setscrew onto the hose and pass the wire cable.

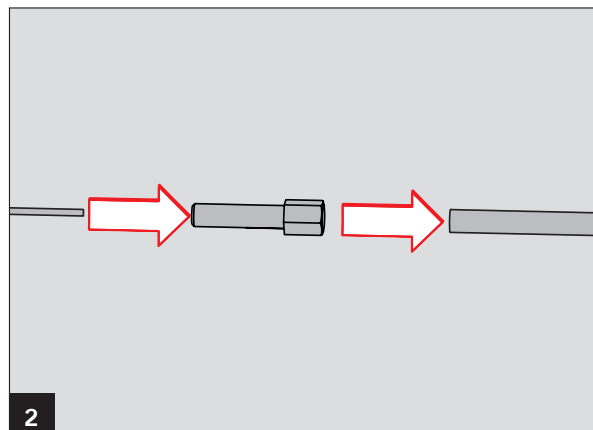

FFT FLEX GREEN / FFT FLEX GREEN 2D

3. Set the locking device into the CLOSE position, screw the setscrew into the base holder and the conternut onto the setscrew.

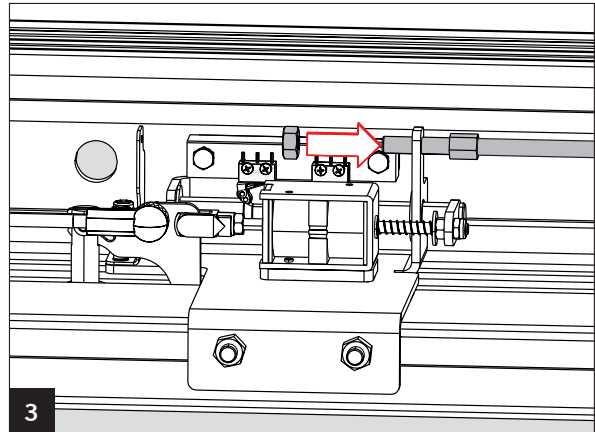

4. Pass the wire cable through the opening on the spring sheet and screw 2 mounting clips at the end of the cable .

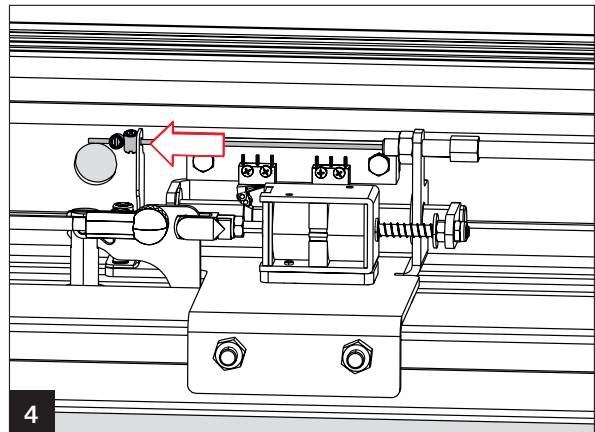

5. In case of a 1-panel door opening to the right, pass the cable in an arc to the left. Carry out steps 6 - 11 on the left wall mounting profile.

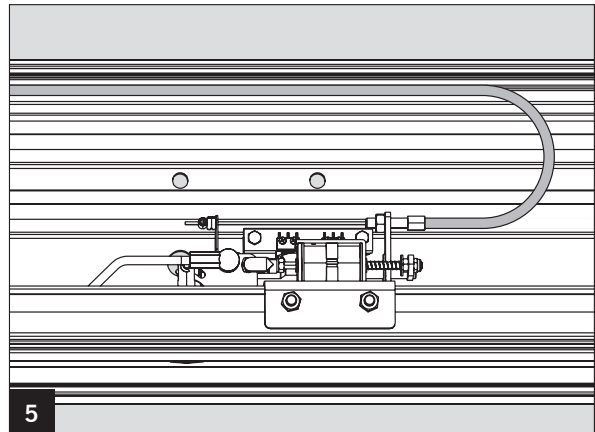

6. Pass the cable from the top into the wall mounting profile.

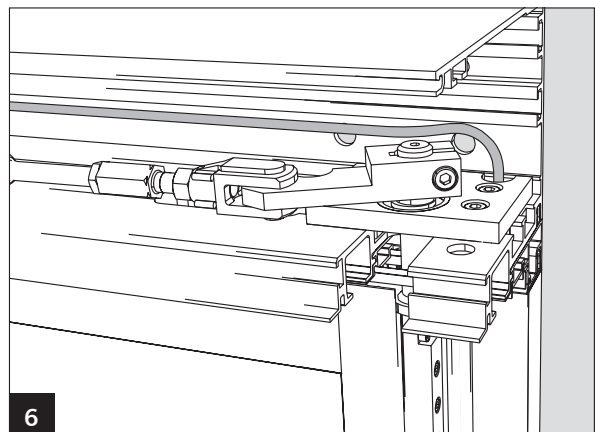

FFT FLEX GREEN / FFT FLEX GREEN 2D

7. At the end of the cable in the wall mounting profile, screw the counternut onto the setscrew.
8. Screw the setscrew into the brackets.
9. Fasten the cable with 2 mounting clips to the manual lock release.

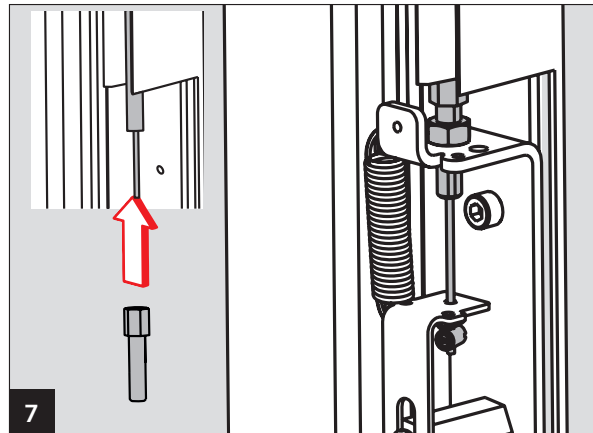

10. If a closing cylinder (profile half cylinder 10/60) is installed, then insert it into the manual lock release and tighten it.
 - 📌 Ensure the correct mounting position of the profile half-cylinder. The key must be inserted from the outside.

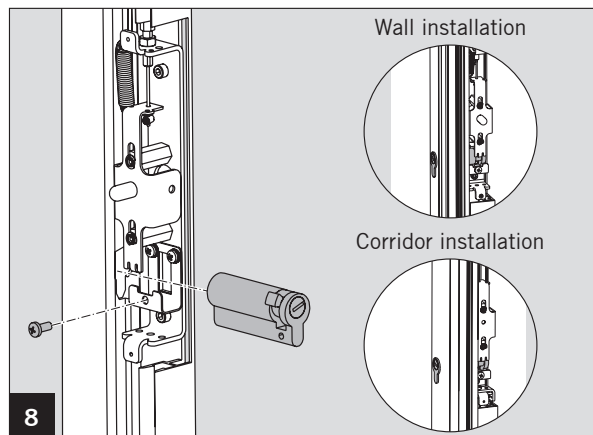

11. Adjust the cable with the setscrews on the locking device and manual lock release so that the locking device can be unlocked.

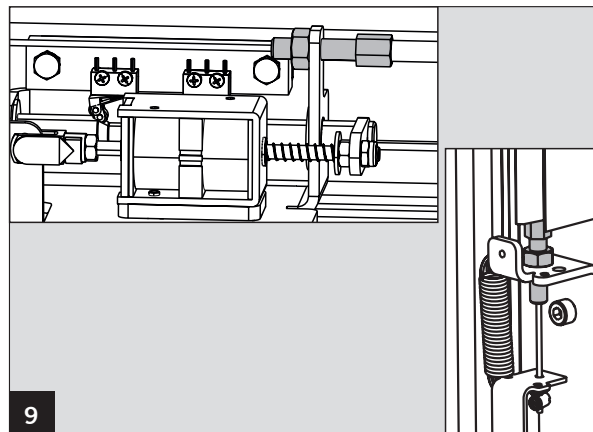

12. Screw the cover to the manual lock release.

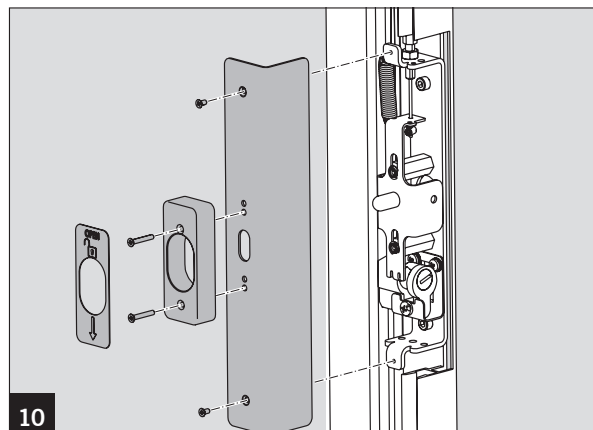

4.6 Installing the MDU

1. Mount the MDU to the drive unit.
2. Screw the MDU to the thread plate in the drive profile using the 4 screws.

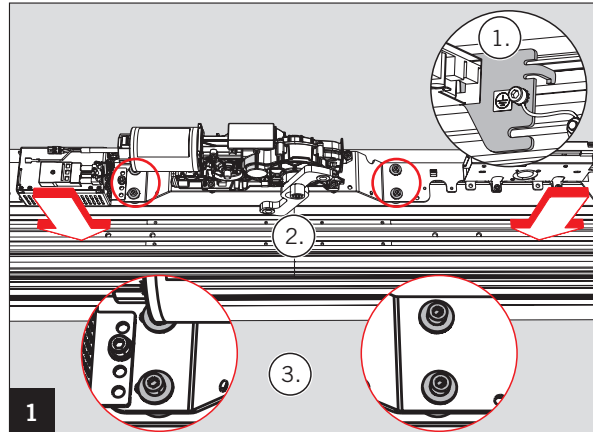

3. Insert one mount each to the right and to the left of the MDU into the profile.
4. Slide the screw connections in the cut-outs in the MDU mount and screw the MDU with the mounts to the drive unit.
5. Tighten the grounding conductor into the profile.

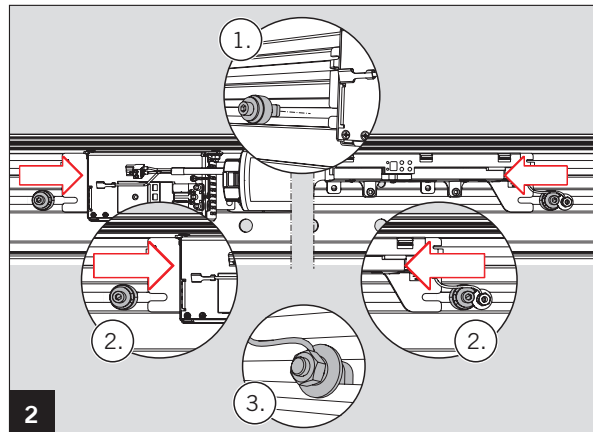

4.7 Preparing the door panels

1. Slide a center seal each on both door panels into the center seal profile and make it flush at the bottom.

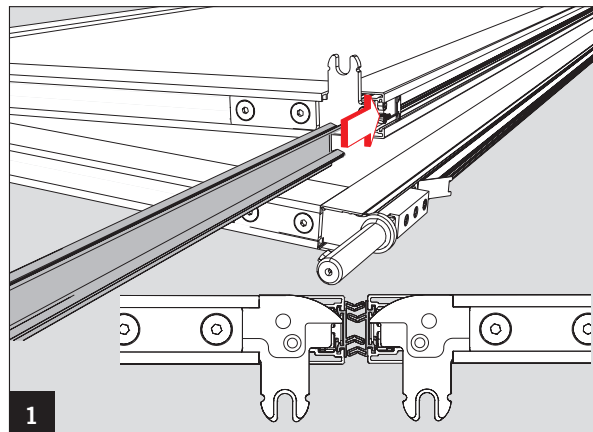

2. Slide on both door panels 2 anti-pinch profiles each into the hinge profiles.

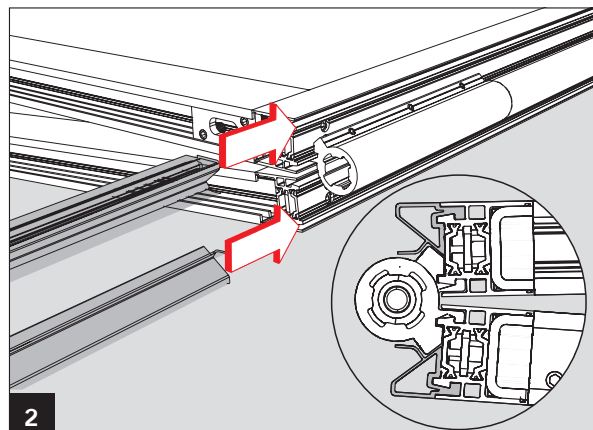

FFT FLEX GREEN / FFT FLEX GREEN 2D

3. Bend or twist the ends of the grayed-out bars on the underside of the door panels in order to secure the anti-pinch profiles in the hinge profiles.

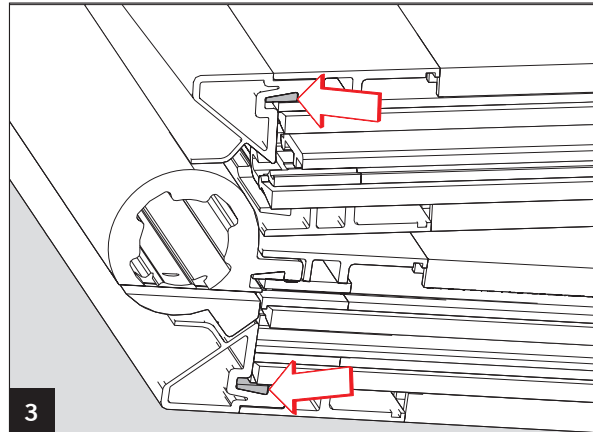

4.8 Installing the door panels

1. Unscrew the support plate.

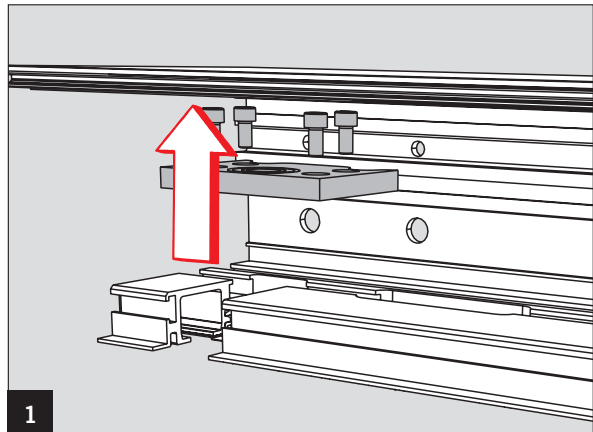

2. Remove the dust cover from the floor bearings.
3. Position the swivel on the center of the ball bearing and put the door in a vertical position.

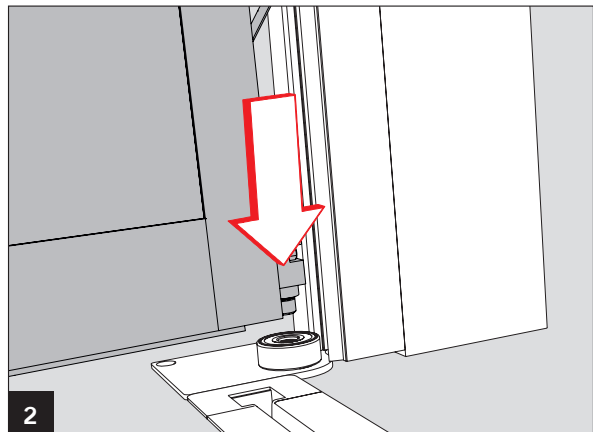

4. Turn the door panel by 90° relative to the drive unit.
5. Insert the upper swivel into the cut-out of the drive profile.
6. Attach the support plate to the swivel.

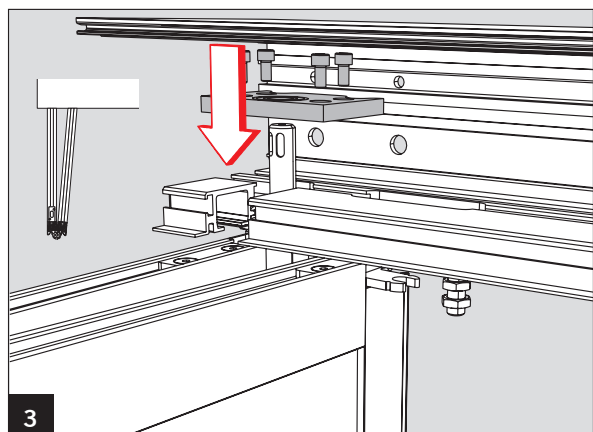

FFT FLEX GREEN / FFT FLEX GREEN 2D

- Align the door panel vertically.
- Screw the support plate to the threaded plates.

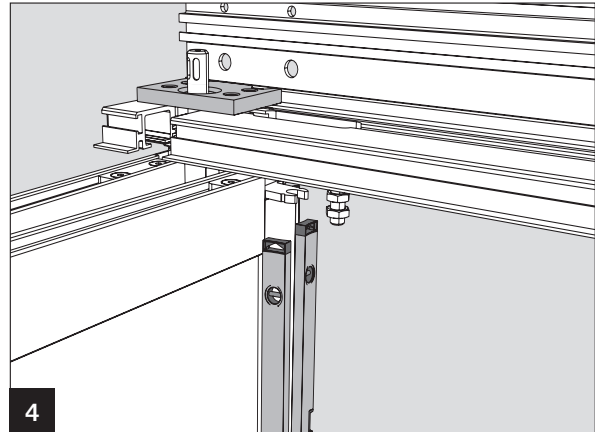

- Close the door panel.
- Insert a track carriage into the drive profile.

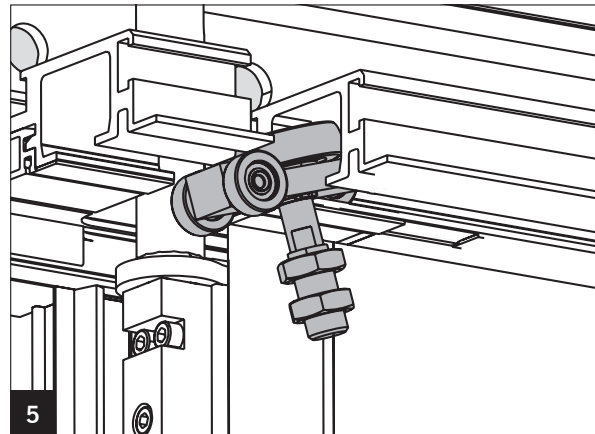

- Insert a floor guide roll into the floor guide rail.

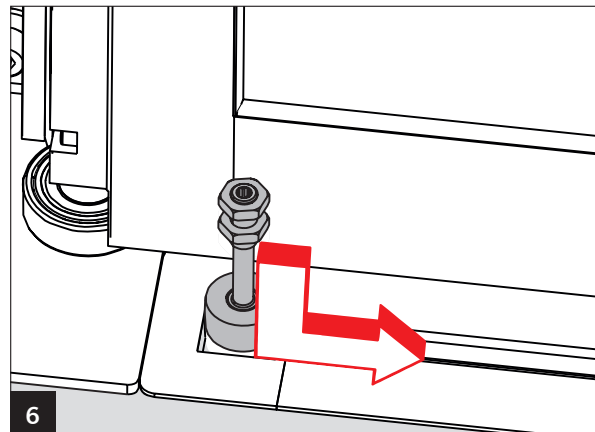

- Insert the track carriage into the guide on the door panel.
- Close the door panel.
- Adjust the height of the track carriage until the center seals of the door panels are parallel to each other.
 - The rolls must carry the door panel along the entire track.
- Tighten the nuts.

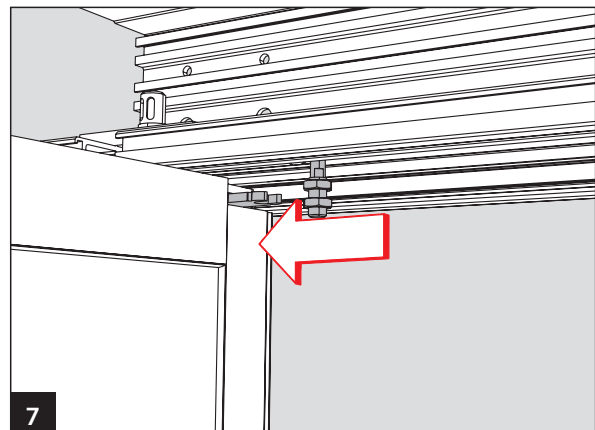

FFT FLEX GREEN / FFT FLEX GREEN 2D

16. Insert the floor guide roll into the guide on the door panel.
 - ☞ The rolls must move freely along the entire track.
17. Adjust the height using the nuts in case the rolls are in contact with the floor guide rail on the top or at the bottom.
18. Tighten the nuts.
19. Install the right door panel in the same way as the left panel.
20. Close both door panels.

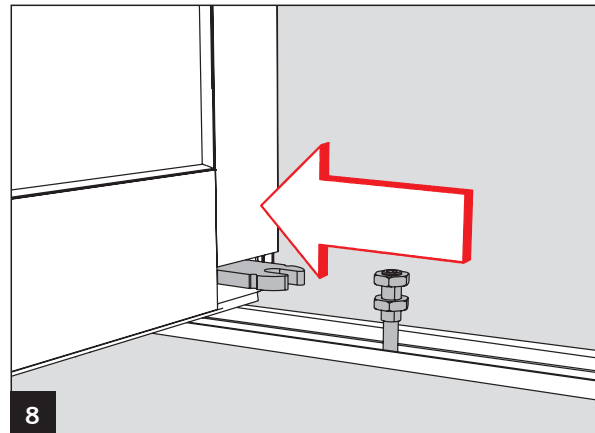

4.9 Aligning the closing edge

You have 2 options to align the gap on the main closing edge to have it parallel. It might make sense to combine both options.

At the upper swivel

1. Loosen the screws on the support plates.
2. Align the door panels to each other.
3. Tighten the screws on the support plates.

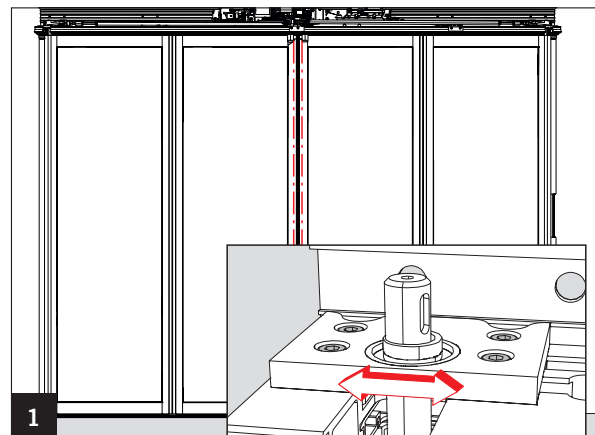

At the floor bearing in case of a wall installation

1. Loosen the cylinder head screws on the floor bearing.
2. Align the door panels to each other.
3. Tighten the cylinder head screws.

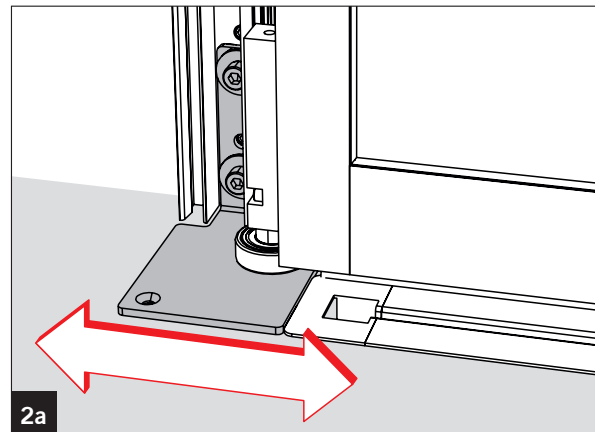

At the floor bearing in case of a corridor installation

1. Loosen the cylinder head screws on the floor bearing.
2. Align the door panels with each other by placing one or several of the U-shaped washers behind the floor bearing. Now push the floor bearing towards the center of the door.
3. Tighten the cylinder head screws.

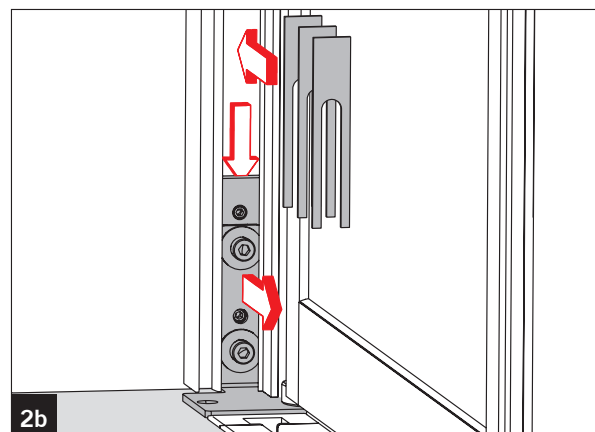

FFT FLEX GREEN / FFT FLEX GREEN 2D

4.10 Fixing the floor bearing

1. Screw the floor bearing to the floor.
 For the fastening, use dowels and screws that match the background.

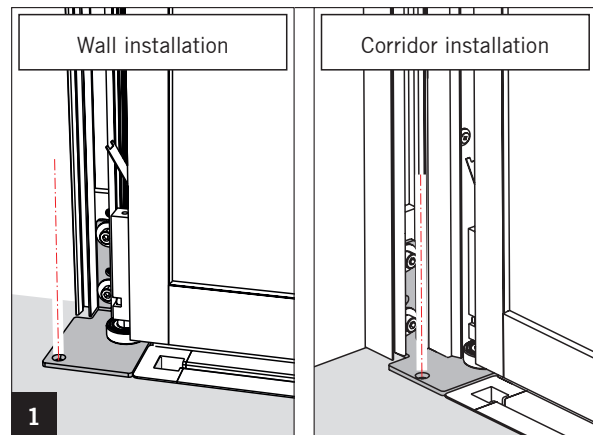

4.11 Fastening the wall mounting profiles

1. Screw the wall mounting profiles through all existing holes.

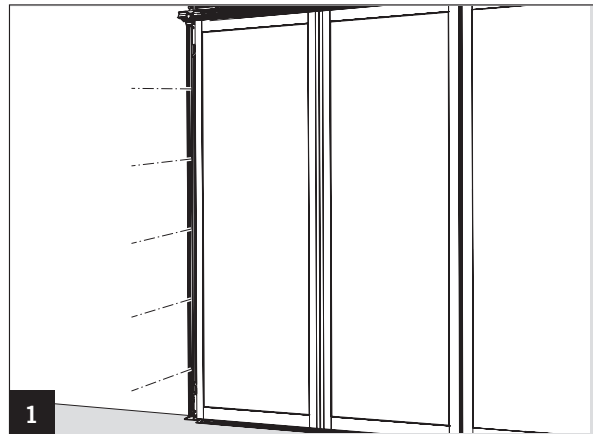

4.12 Cover on the wall mounting profile in case of a single-panel wall installation

1. Press the cover into the channels on the wall mounting profile.

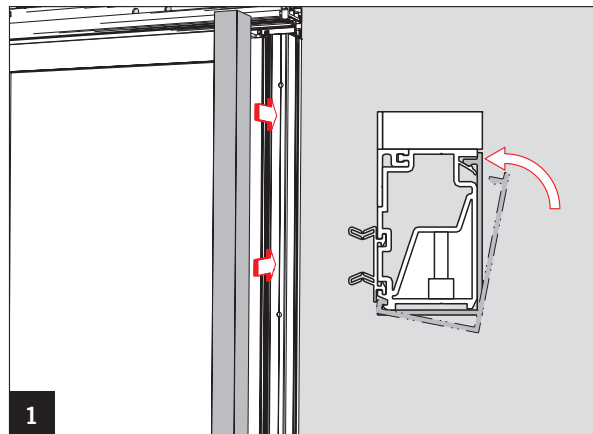

4.13 Mounting the covers to the wall mounting profiles

1. Press the cover into the channel on the wall mounting profile.
 When a manual lock release is used, the corresponding cover consists of 2 parts.

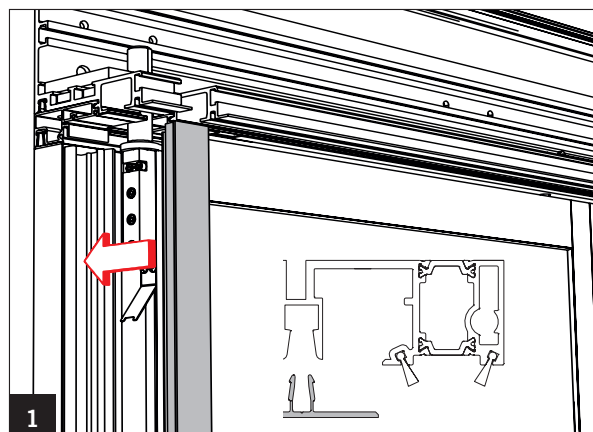

FFT FLEX GREEN / FFT FLEX GREEN 2D

4.14 Mounting the cover caps

1. Remove the grey parts of the cover caps.

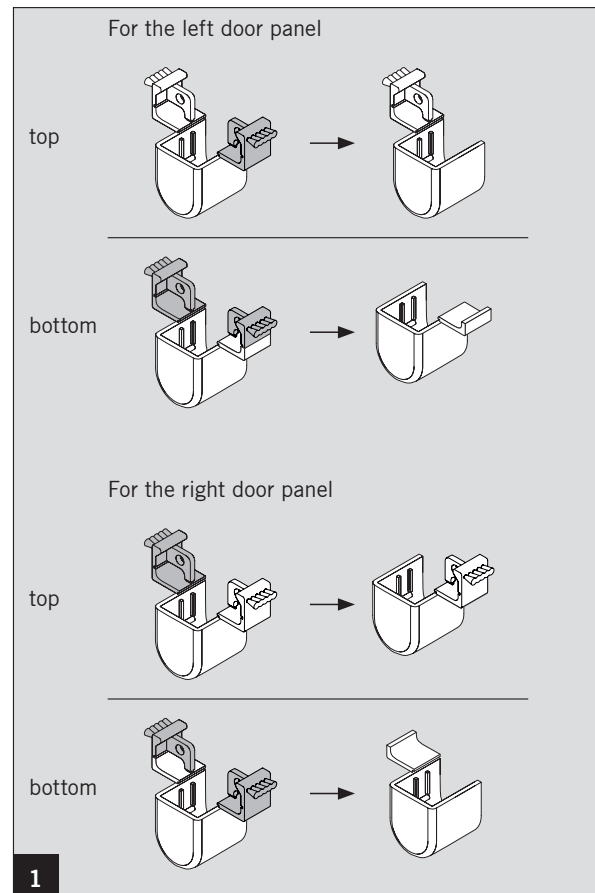

2. Attach the cover caps.

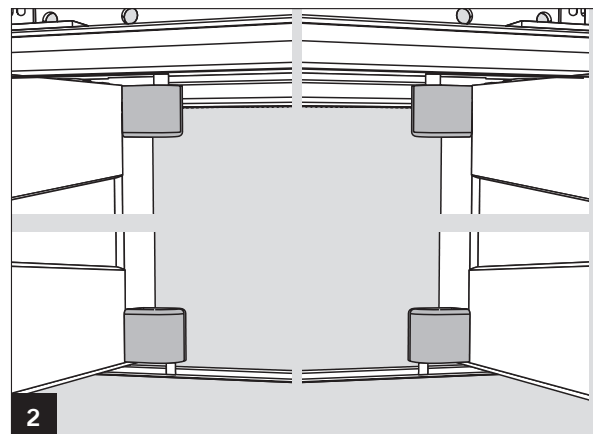

FFT FLEX GREEN / FFT FLEX GREEN 2D

4.15 Preparing the rods

The rods have been completely prepared in the factory.

- ✎ Prior to the installation, check the measurement **L** according to the formulas listed below and adjust, if applicable.
- ✎ After the installation, only use the adjustment screw marked in red for the adjustment.

Double panel: $L = (LW/2) + 115 \text{ mm}$

Single panel: $L = (LW/2) + 54 \text{ mm}$

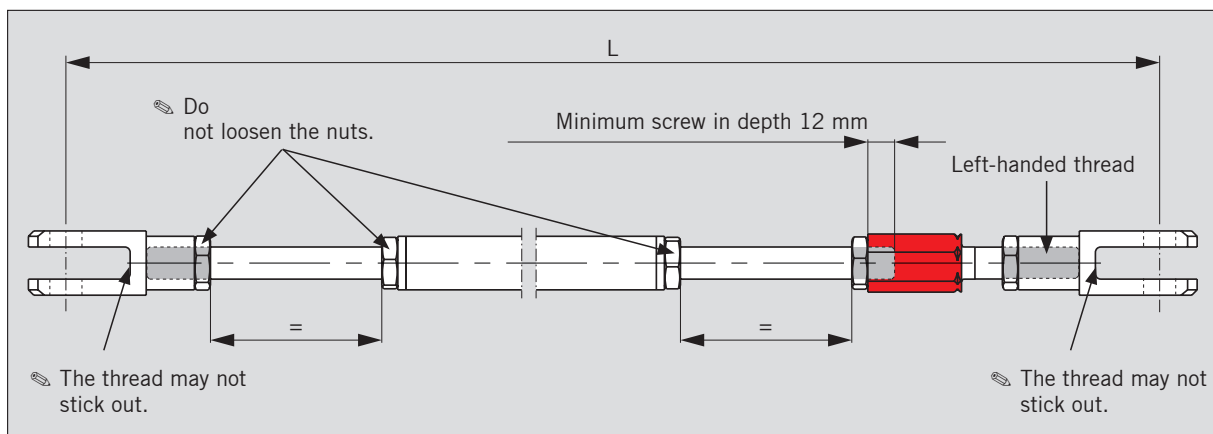

4.16 Mounting the rods

1. Attach the spacer to the swivel.
2. Insert the feather key into the channel.
 - ✎ For the feather key, use the channel that is pointing outward.
3. Attach the drive arm onto the swivel and tighten.
 - ✎ Pay attention to the mounting position.

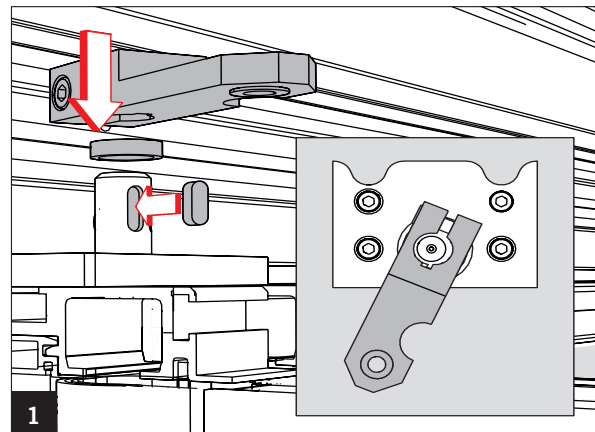

Installation layout with the door closed, top view

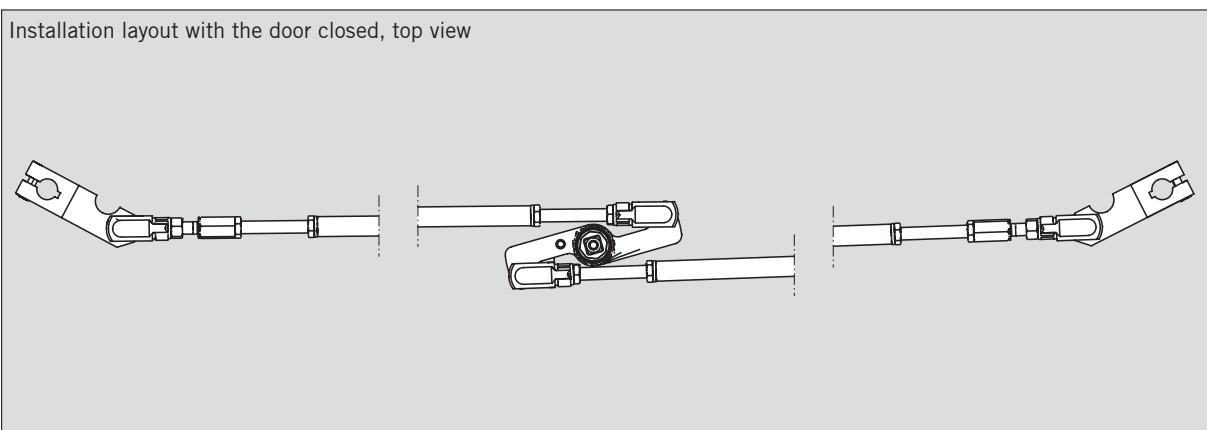

FFT FLEX GREEN / FFT FLEX GREEN 2D

4. Turn the rotational guide lever so that the forkhead can be attached.
5. Install the left rod into the drive unit.
6. Tighten the fork heads using the clips. Put the spring bolt through the bearing and clip the spring onto the fork head.

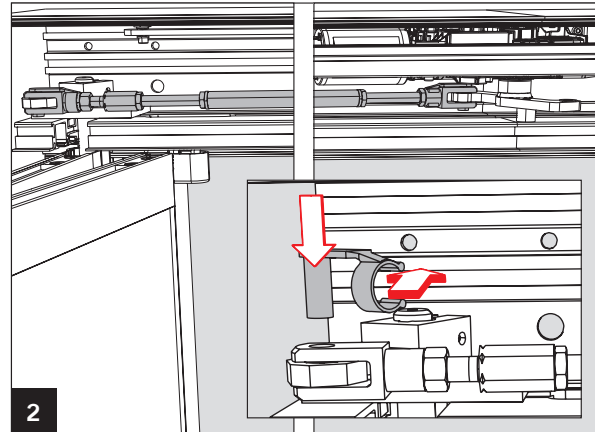

7. Close the left door panel.
8. Adjust the length of the rod so that the door panel rests against the locating surface of the drive profile but so that the rotational guide lever is short of being in contact with the rod.

Use the enclosed wrench.

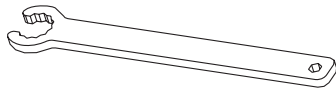

9. Tighten all counternuts.
 - Further adjustments are made via the right rods.

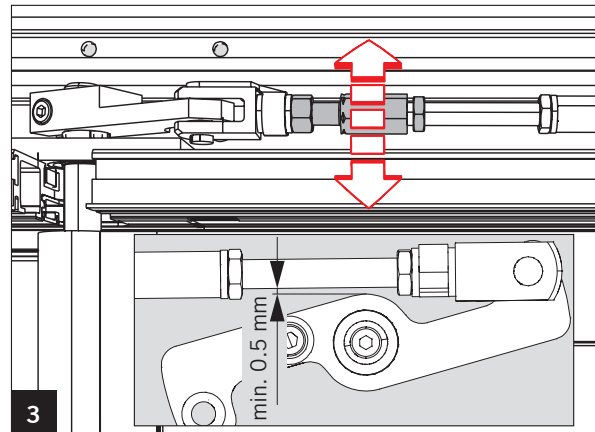

10. Close the right door panel.
11. Fasten the right rods with the clips on the rotational guide lever and the right drive arm.

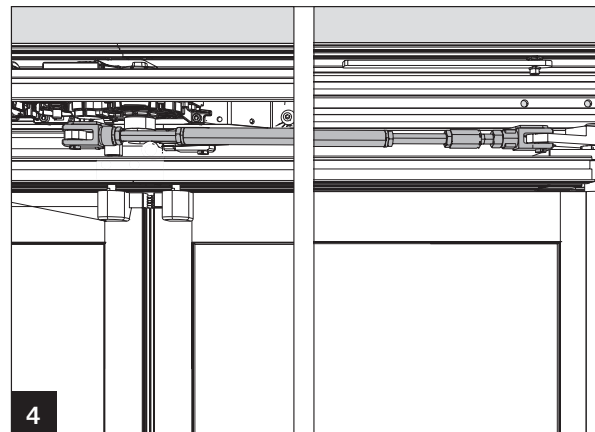

12. Adjust the right door panel via the adjusting piece so that both door panels rest evenly against the stop bar of the drive unit.

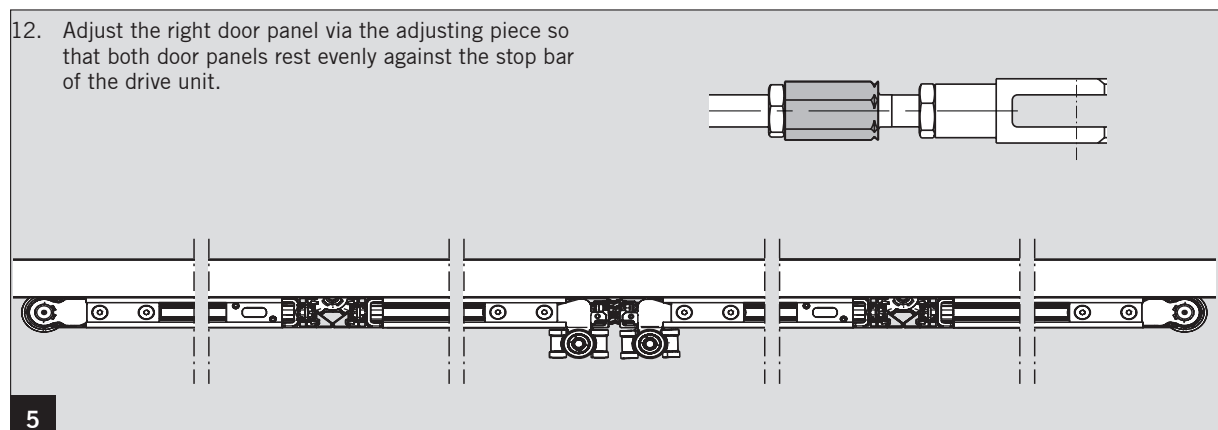

4.17 End stop installation

1. Push the end stop from the right into the drive profile.

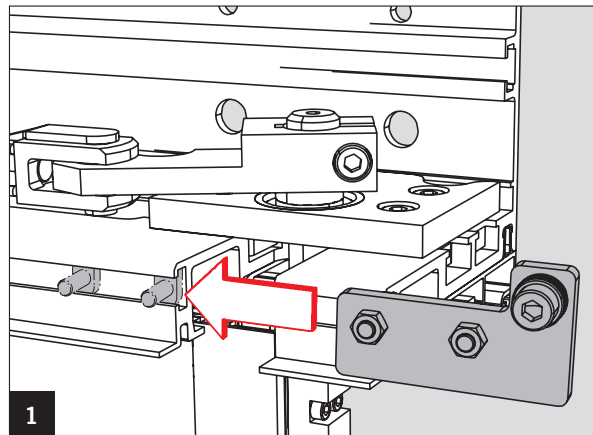

2. Open the door to the opening width (Clear width ± 20 mm) so that the outer part of the right door panel is exactly 90° relative to the drive unit.

 The other dimensions are achieved automatically.

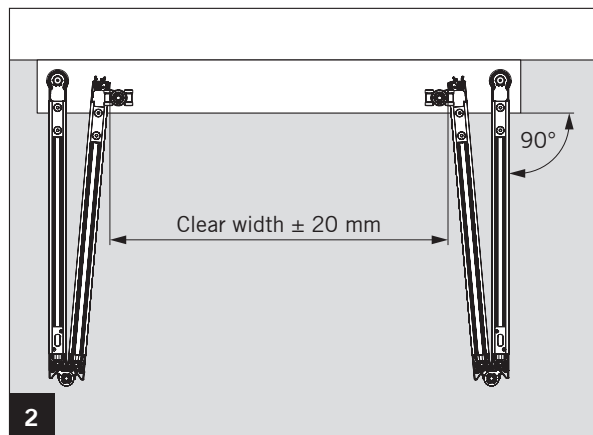

3. Push the end stop against the rotational guide lever.
4. Tighten the end stop.

 The positions of the two door panels are not symmetrical due to the special drive geometry of the folding door.

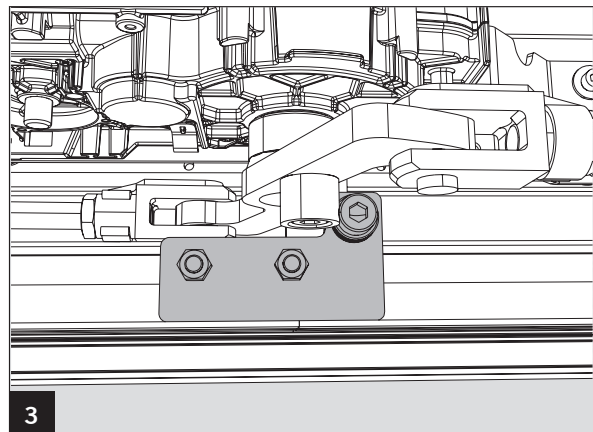

4.18 Mounting the cable duct

1. Insert the cable duct holder into the drive profile from the outside.
2. Position the cable duct in the center of the drive and tighten it.

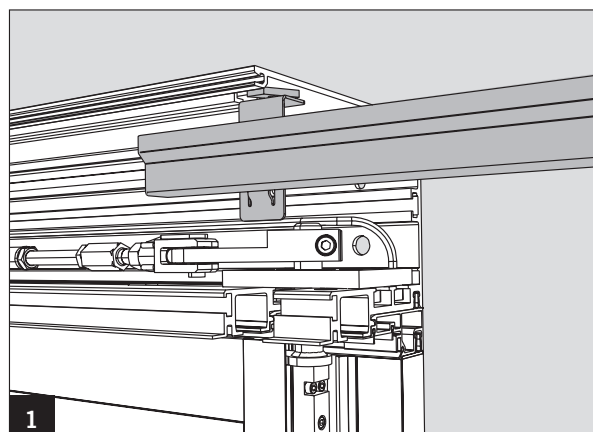

4.19 Cable duct installation

1. Insert the nuts of the cable holder into the drive profile from the outside.
2. Position the cable holders as needed and tighten them.

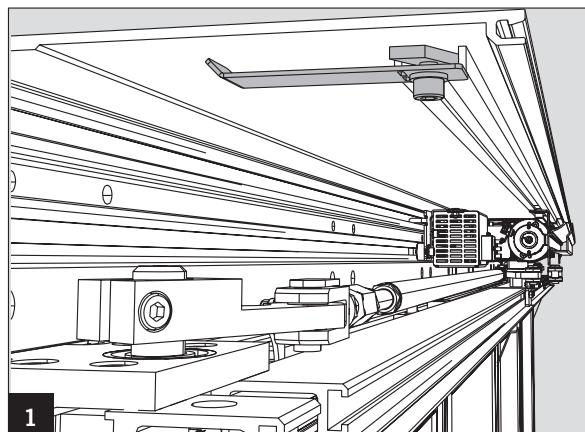

4.20 Mounting the battery

1. Insert the two hammer head screws from the right into the drive profile.
2. Position the battery to the right from the MDU and tighten it.

⚠ Ensure the correct mounting position. An incorrect mounting position may result in a short-circuit.

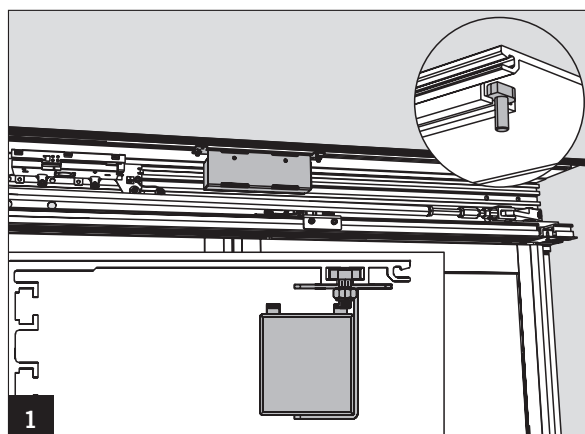

4.21 Mounting the cover for the swivel cover

1. Insert the two screws into the drive profile.
2. Tighten the swivel cover.

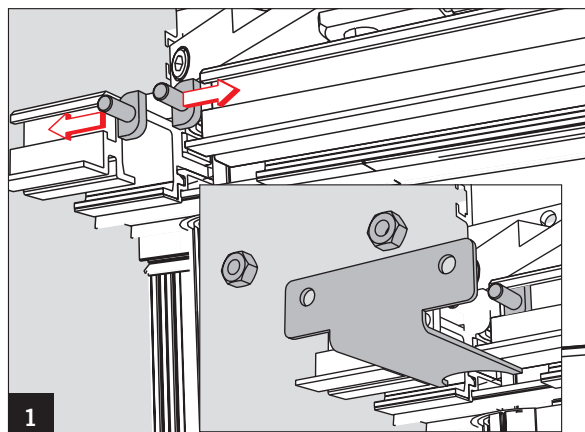

4.22 Inner cover installation

1. Insert the hinge profiles into the inside panel and distribute them evenly.
2. Screw the front plates to the side of the inside panel.

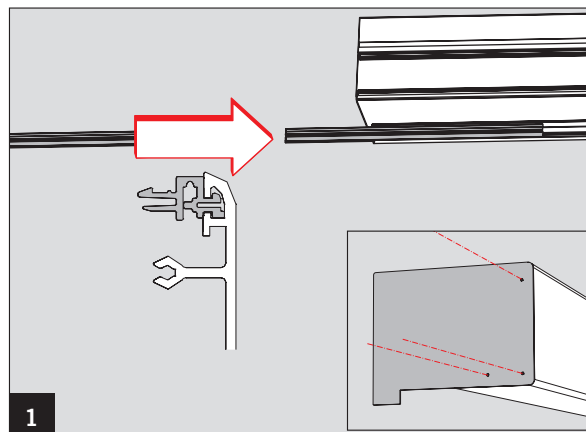

3. Insert the holder for the inside panel into the drive profile from both sides.
4. Position the holders so that they can be turned into the drive unit and tighten them.

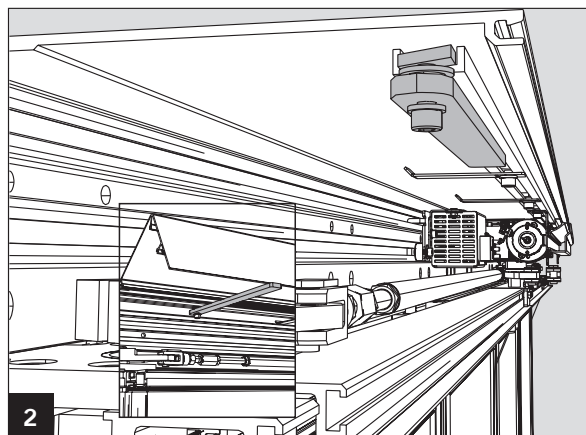

5. Fix the inside panel by slightly banging against the drive profile with the heel of your hand.
6. Close the panel. In order to lock it in place, press the panel from below slightly against the drive unit.

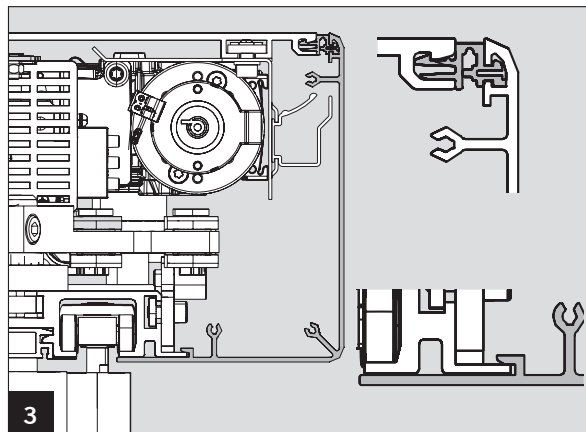

7. Drill on both sides at the specified point through the panel and the drive unit profile.
8. Countersink the holes.
9. Fasten the inside panel with 2 countersunk screws KRZ B3.9 x 19 to the drive unit profile.

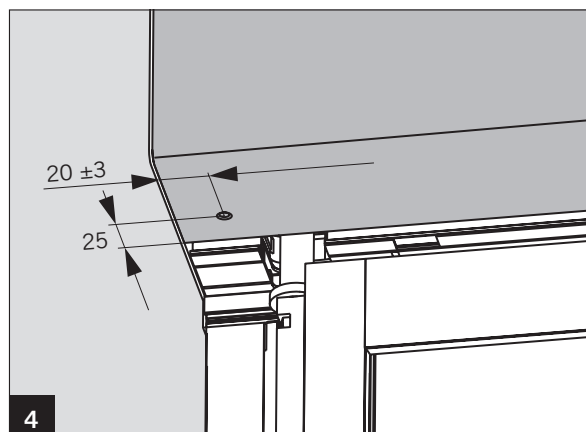

4.23 Mounting the rail profile

1. Place the rail profiles in such a way that the notch is at the bottom and that they are flush with the door panels.
2. Fix them by slightly banging against the door panels with the heel of your hand.

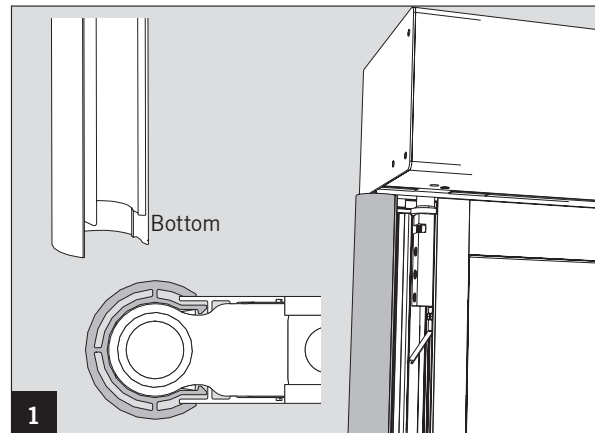

4.24 Mounting the components

⚠ Work on electrical equipment may only be performed by properly qualified specialists.

1. Connect to the mains.
2. Install the program switch and other external components according to the enclosed instructions and connect them.

3. Install the sensors according to the enclosed instructions but do not yet connect them.

📌 The sensors on the inner side of the drive unit have to be mounted to the inner cover whereas the lower edge of the sensors may not lie more than 20 mm above the lower edge of the cover.

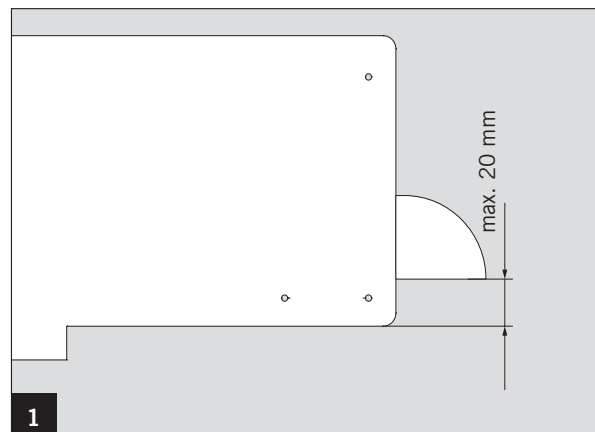

4.25 Wiring inside the drive unit

1. In order to prevent a collision with moving parts, always run the cables within the drive unit inside the cable holders or in the center of the drive unit inside the cable duct.

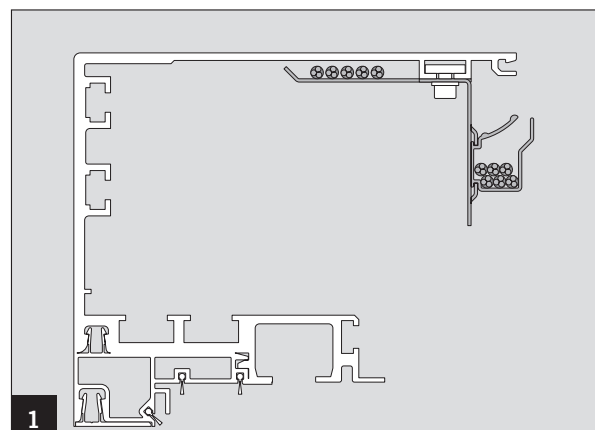

4.26 Mounting the cover angles (corridor installation)

1. Position the cover angles from the outside so that the hollow space is covered on the top, the bottom and on the sides of the drive unit.

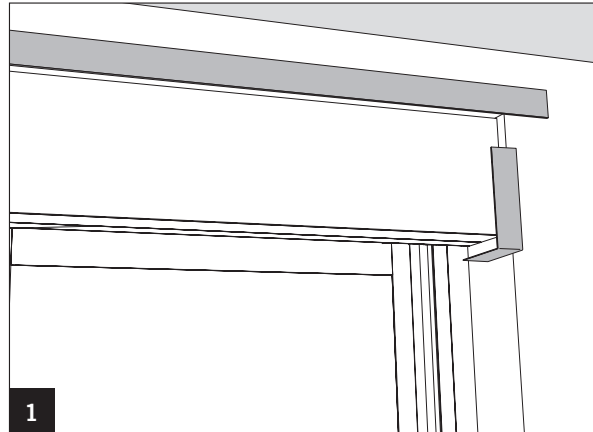

2. Glue the angles with silicon.

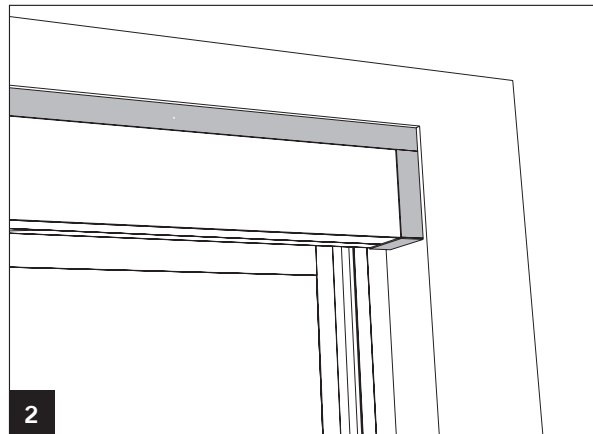

4.27 Fanlight installation (optional)

1. Place the two vertical wall mounting profiles to the right and left of the carrier section.
2. Align them vertically.
3. Screw them to the walls.

☞ For the fastening, use dowels and screws that match the background.

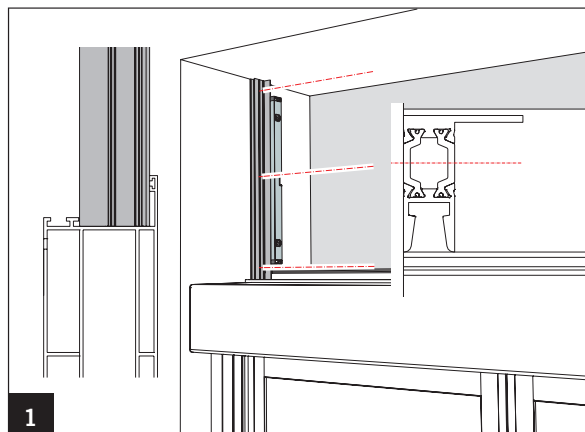

4. Align the horizontal wall mounting profile along the two verticals.
5. Tighten it.

☞ For the fastening, use dowels and screws that match the background.

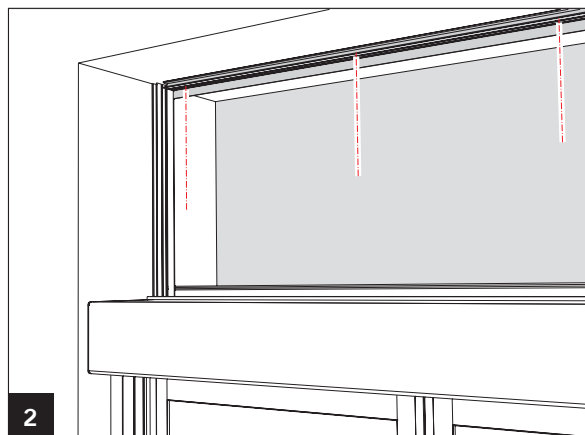

6. Place the left fanlight on the carrier profile.
7. Push it until flush with the wall mounting profile.

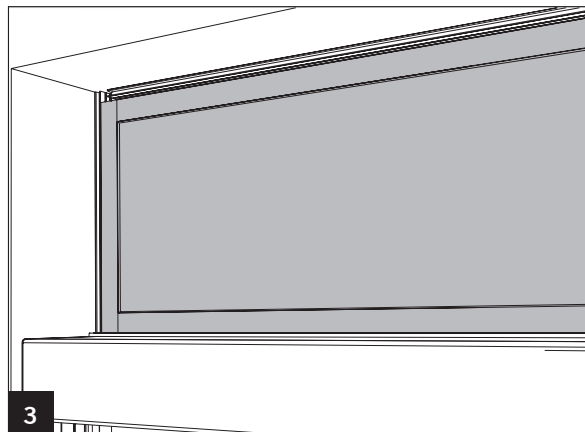

8. Insert the foam rubber seal from the right into the profile of the fanlight.

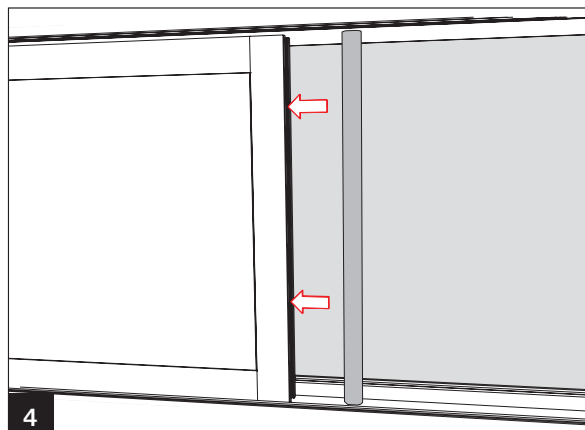

FFT FLEX GREEN / FFT FLEX GREEN 2D

- Place the right fanlight on the carrier profile.
- Push the fanlight until flush with the right wall mounting profile. The foam rubber seal has to fit into the profile of the fanlight.

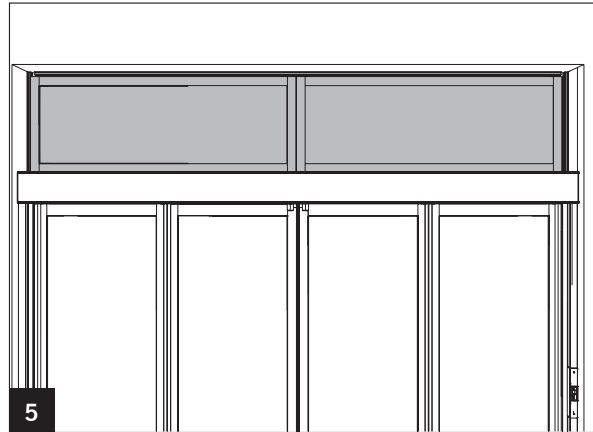

- Insert the covers with the nose inside the channel into the wall mounting profiles.

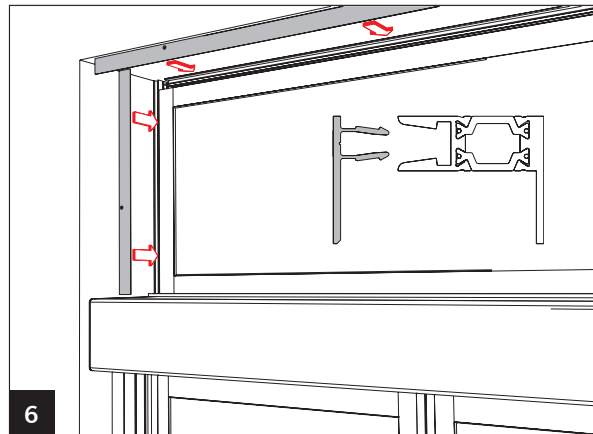

- Screw on the covers.

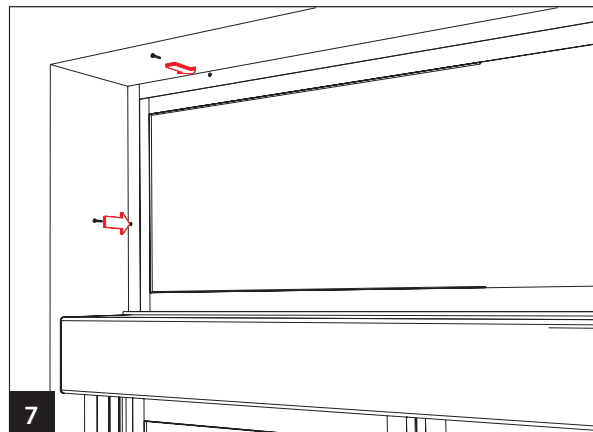

- Seal the fanlight around the outer side using silicone.

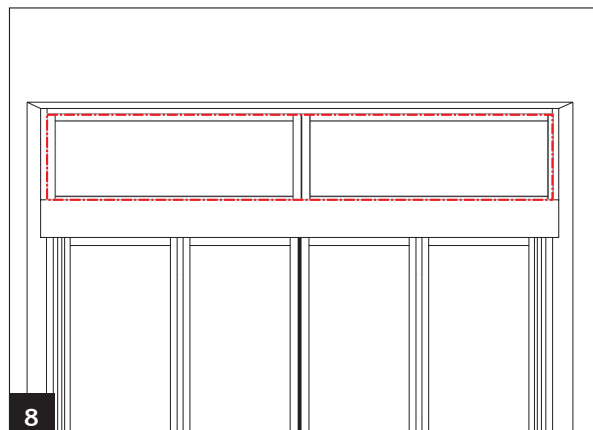

5. Commissioning

⚠ Work on electrical equipment may only be performed by properly qualified specialists.

Requirements

- The drive unit is installed.
- The grounding conductor is connected.
- The program switch, EMERGENCY STOP button and activator, (microwave detector, night/bank switches) are installed and connected.
- The connections for the sensors are bridged.
- The sliding door panels are moving freely.
- The program switch is in the OFF position.

Setting the control to the factory setting

1. Pull the power plug from the control unit.
2. Half open the door panel.
2. Plug the power plug into the control unit.
3. Immediately push the service key and hold it until the two yellow safety LEDs are on.
 - ▶ The control is now set to the factory setting.
 - ▶  flashes.

Setting the opening width

- 🔧 In order to be able to carry out the commissioning, you must first set the opening width.
- 🔧 When you set the opening width, we recommend using the hand terminal.
- 🔧 In case of single panel systems, the number of panels parameter must be set via the hand terminal to single panel before the opening width is set.

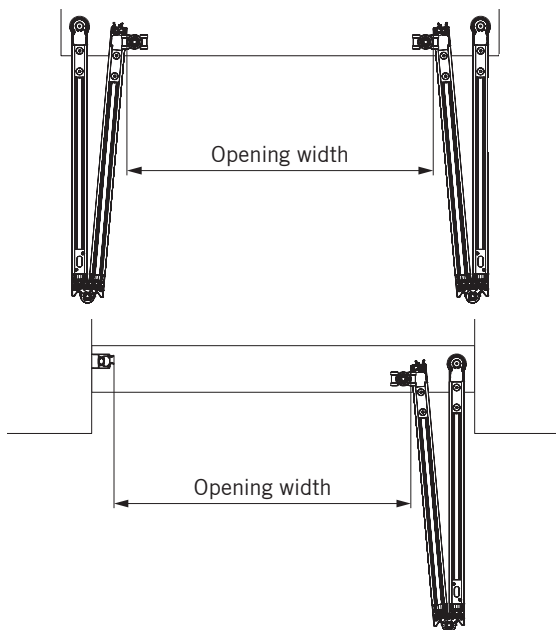











Setting the opening width via hand terminal

1. Open the door until it is fully open.
2. Measure the opening width.
3. Enter the opening width.
4. Confirm the input.
 - ▶ The door performs a teach-in run in the closing direction.
 - 🔧 If the teach-in movement starts with an opening movement, press the minus key on the control unit. This will change the sense of rotation of the motor.

Setting the opening width on the control unit

The opening width is entered with 4 digits in mm. Each digit is individually entered.



1. Measure the opening width.
2. Press the select key.
3. Use the button (+) (-) to select the parameter .
 - ▶  will be displayed.
4. Press the select key.
 - ▶  flashes for the setting of the thousands.
5. Press the select key.
 - ▶  lights.
6. Use the (+) (-) button to set the first digit.
7. Press the select key.
 - ▶  flashes for the setting of the hundreds.
8. Press the select key.
 - ▶  lights
9. Use the (+) (-) button to select the second digit.
10. Press the select key.
 - ▶  flashes for the setting of the tens.
11. Press the select key.
 - ▶  lights
12. Use the (+) (-) button to set the third digit.
13. Press the select key.
 - ▶  flashes for the setting of the ones.
14. Press the select key.
 - ▶  lights
15. Use the (+) (-) button to set the fourth digit.
16. Press the select key.
 - ▶ The value will be saved and  lights up.

FFT FLEX GREEN / FFT FLEX GREEN 2D

Teach-in run

1. Turn the program switch to the OFF position.
2. Press the service button until the display spins. 
 - ▶ The door first performs an opening movement and then a closing movement.

Teach-in run after a mains reset

1. Turn the program switch to the OFF position.
The dot  must light up.
2. Press the service button until the display spins. 
 - ▶ The door first performs an opening movement and then a closing movement.

Setting the maximum opening speed

The opening speed for restricting the dynamic forces is set according to DIN18650 or EN16005 at the secondary closing edge.
Due to the special design of the door panels, the door panel forces can be measured only under laboratory conditions. A measurement on site is not required.
In case of other door dimensions, select the setting value for the next largest or next highest door from the table.

The tables provide the maximum opening speed in % per second.

For glass weight 25 kg/m²

Opening width [mm]		Clear height [mm]					
Double panel	Single panel	2000	2100	2200	2300	2400	2500
900		55	54	53	52	51	50
1000		53	52	51	50	49	48
1100		51	50	49	48	47	46
1200		49	48	47	46	45	44
1300		47	46	45	44	43	42
1400		45	44	43	42	41	40
1500		43	42	41	40	39	38
1600	800	41	40	39	38	37	36
1700	850	39	38	37	36	35	34
1800	900	37	36	35	34	33	32
1900	950	35	34	33	32	31	30
2000	1000	33	32	31	30	29	28
2100	1050	31	30	29	28	27	26
2200	1100	29	28	27	26	25	24
2300	1150	27	26	25	24	23	22
2400	1200	25	24	23	22	21	20

Commissioning the safety sensors

 **The door system can only be operated safely if the sensor system works properly. This is why the system may not be operated with a bridged sensor system.**

The factory setting for the control unit is such that the door panels moving through the sensor range are automatically suppressed (the value can be adjusted).
Set the activation width of the safety inside via the hand terminal. The door will reverse only with the safety inside activated if the current position of the door is below the activation width.

After the commissioning, check the settings and the functionality of the FFT and the protection devices for their proper mechanical condition.

Instruction

After the successful setting, commissioning and functional check of the door system, hand over the assembly and operating instructions to the owner and instruct him on the operation and maintenance of the door system.

Doors along escape routes:

In case of escape route doors, the "80% door opening in 3s" (see DIN18650-1, point 5.8.2.4.1) takes priority over the restriction of the maximum dynamic forces!
The automatically taught default value of the opening speed [%/s] in case of escape route doors may be increased only to the maximum value specified in the table.
If the taught opening speed already exceeds the value in the table, it may not be further increased.

For glass weight 30 kg/m²

Opening width [mm]		Clear height [mm]					
Double panel	Single panel	2000	2100	2200	2300	2400	2500
900		50	49	48	47	47	46
1000		48	47	47	46	45	44
1100		47	46	45	44	43	42
1200		45	44	43	42	41	40
1300		43	42	41	40	39	38
1400		41	40	39	38	37	37
1500		39	38	37	37	36	35
1600	800	37	37	36	35	34	33
1700	850	36	35	34	33	32	31
1800	900	34	33	32	31	30	29
1900	950	32	31	30	29	28	27
2000	1000	30	29	28	27	26	26
2100	1050	28	27	26	26	25	24
2200	1100	26	26	25	24	23	22
2300	1150	25	24	23	22	21	20
2400	1200	23	22	21	20	19	18

6. Error display

Only the current error can be acknowledged.

Errors must first be eliminated and then acknowledged,

It is possible to save up to 10 errors (depending on their type)

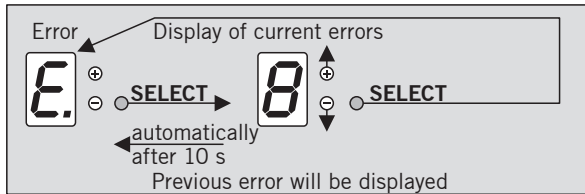

Display	Error	Type of acknowledgement
0	No error in memory	
1	Obstacle	Acknowledges automatically
2	Locking device	Switch the program switch to OFF.
3	Program switch	Switch the program switch to OFF.
4	Main closing edge	Acknowledges automatically
5	Incremental encoder	Acknowledges automatically
6	Battery	Switch the program switch to OFF.
7	System	Perform a mains reset.
8	EMERGENCY STOP button is pressed in.	Unlock EMERGENCY stop button.
9	Teach-in run parameters	Switch the program switch to OFF.
R	Motor	Acknowledges automatically
C	Force test	Acknowledges automatically
d	Excess current	Switch the program switch to OFF.
F	DCW	Perform a mains reset and switch to the factory setting.
L	Relay test	Perform a mains reset.
H	Collective fault (only in case of 2D drive)	Switch the program switch to OFF.

Errors during the commissioning

If the teach-in run starts with an opening movement press the minus key on the control unit. This will change the sense of rotation of the motor.



Additional error displays appear on the hand terminal.

7. Troubleshooting

In case errors occur during the commissioning or the operation, first check the following:

- Check the wear parts and replace them, if necessary.
- Mains voltage available?
- Is the EMERGENCY STOP button unlocked?
- Is the program switch in the correct position?
- Is the door blocked by objects?
- Are the door panels running smoothly (guide rollers top/bottom)?
- Are all external activators, EMERGENCY STOP buttons, program switch and lock correctly wired?
- Are all connection pairs tight?
- Is the battery connected?

The following table will provide further assistance. Keep the control unit de-energized during the installation. Once the error is eliminated, acknowledge the message by switching the program switch to OFF.

Error	Possible cause	Remedy
Teach-in run/factory settings are not carried out - the door moves into the OPEN position.	Safety sensors activated.	Bridge the connecting terminals.
After a self-test, the door stays in the OPEN position.	The battery is not full or low.	Change the battery.
The door is open in all program switch positions.	EMERGENCY STOP switch is pressed in or defective.	Bridge the inputs on the connector. If this eliminates the error, check the EMERGENCY STOP switch and replace it, if necessary.
Door is open in the program switch positions AUTOMATIC, EXIT ONLY and PARTIAL OPEN.	Sensor provides a continuous pulse.	Disconnect the sensor. If this eliminates the error, replace the sensor.
Basic module shows error "1" (obstacle) during the commissioning.	Teach-in run has not yet been performed (no door weight determination).	Perform a teach-in run.
	The setting for the obstacle detection is too sensitive.	Adjust the obstacle detection via the Force limitations (OPEN, CLOSED) and Obstacle time settings.
Door does not open in the program switch positions AUTOMATIC, EXIT ONLY, and PARTIAL OPEN.	External detector without function.	Pull the plug for the sensor and bridge the input. Once the error has been eliminated, check the voltage supply (27 V) at the basic module and sensor. If OK, check the sensor and replace it, if necessary.
	Internal detector without function.	Disconnect the plug for the sensor. If the door opens, check the voltage supply (27 V) on the basic module and sensor. If OK check the sensor and replace it, if necessary. Check whether an inherently safe detector with closed circuit principle is used.
Basic module indicates error "H".	The basic module searches for the FST module.	Reset the control unit to the factory setting and perform a teach-in run.

FFT FLEX GREEN / FFT FLEX GREEN 2D

Appendix

Control unit basic module

- ① LED 1
- ② LED 2
- ③ menu navigation: 7-segment display
- ④ + "Plus" key
- ⑤ - "Minus" key
- ⑥ SEL "Select" key
- ⑦ SERV "Service" key

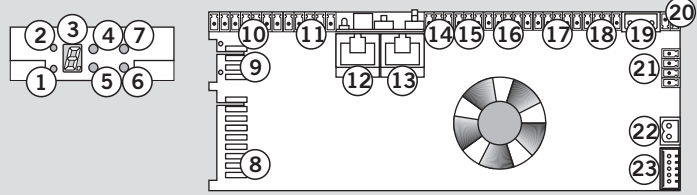

If DWC connections have been interchanged or if the GND connection is missing, then this may result in the destruction of all connected DCW users.

⑧				FST Interface	
	48	+ 27 V DC		DCW Interface	
⑨	47			Signal A	
	46			Signal B	
	45	⊥		GND	
	1	←		Program switch	OFF
	2	←			AUTOMATIC
	3	←			EXIT ONLY
⑩	4	←			PARTIAL OPEN
	5	←			PERMANENT OPEN
	6	→	⊥	GND	GND
	7	←			Night/bank
	8	→	⊥	GND	GND
	9	→	+ 27 V DC	Locking device	Power supply
	10	→			Lock
⑪	11	←			Response
	12	→			Unlock
	13	→	⊥	GND	GND
⑫				Interconnection LON adapter	
⑬				Service Interface für PDA	
	14	→	+ 27 V DC	Detector external	Power supply
⑭	15	←			External detector
	16	→	⊥	GND	GND
	17	→	+ 27 V DC	Detector inside	Power supply
⑮	18	←			Internal detector
	19	→	⊥	GND	GND
	20	→	+ 27 V DC	Safety 2 (Protection inside)	Power supply
	21	←			Recipient 2
⑯	22	→	+ 27 V DC		Power supply
	23	→			Sender 2
	24	→	⊥	GND	GND
	25	→	+ 27 V DC	Sicherheit1 (Protection outside)	Power supply
	26	←			Recipient 1
⑰	27	→	+ 27 V DC		Power supply
	28	→			Sender 1
	29	→	⊥	GND	GND
	30	→		Service	Service output (open Source, 1.5A)
⑱	31	→	+ 27 V DC		Power supply
	32	→		EMERGENCY STOP	GND
	33	←			EMERGENCY STOP
	34	→			Inhibit
⑲	35	←	⊥	GND	GND
	36	←	+ 35 V DC	Power supply	Power supply
⑳	37	←		Battery	Batt +
	38	←			Batt -
	39	→	+ 27 V DC	DCW Interface	
㉑	40	→		Signal A	
	41	→		Signal B	
	42	→	⊥	GND	
㉒	43	←		Motor	
	44	←			
㉓				Incremental encoder	

FFT FLEX GREEN / FFT FLEX GREEN 2D

Appendix

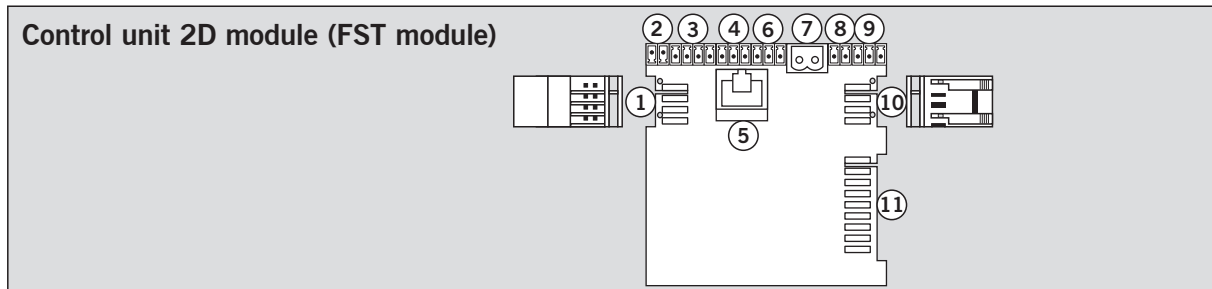

If DCW connections have been interchanged or if the GND connection is missing, then this may result in the destruction of all connected DCW users.

①	27		27 V DC	DCW Interface
	26		Signal A	
	25		Signal B	
	24		GND	
②	1		→ +	Battery
	2		→ -	
③	3		→ + 27 V DC	Internal detector (inherently safe)
	4		← 20 mA	
	5		← 20 mA	
	6		→ ⊥ GND	
④	7		→ Lock	Locking device
	8		→ + 27 V DC	
	9		→ Unlock	
⑤				Programming interface
⑥	10		← Unlock	Key switch button KT8
	11		→ ⊥ GND	
	12		← Lock	
⑦	13		→	Motor auxiliary drive
	14		→	
⑧	15		→	Alarm contact
	16		→	
⑨	17		←	PGS 2. Level fault LED
	18		→ +	
	19		→ -	
⑩	20		⊥ GND	DCW Interface
	21		Signal B	
	22		Signal A	
	23		+ 27 V DC	
⑪				FST Interface

FFT FLEX GREEN / FFT FLEX GREEN 2D

Appendix

Control unit functional module

Switching capacity of digital outputs
 1A 30V DC
 0.5 A 125V AC
 0.3 A 60V DC

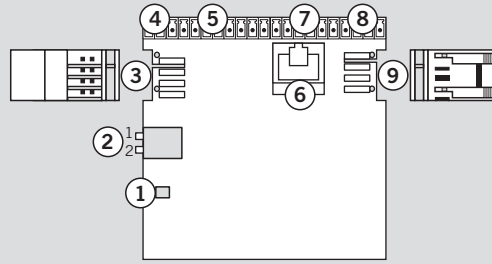

If DCW connections have been interchanged or if the GND connection is missing, then this may result in the destruction of all connected DCW users.

①				Operation LED
②				DIP switch
③	29	27 V DC		DCW Interface
	28	Signal A		
	27	Signal B		
	26	GND		
④	1	→ + C	↔	OUT 1
	2	→ - NO	↔	
	3	→ + NC	↔	OUT 2
	4	→ C	↔	
	5	→ NO	↔	OUT 3
	6	→ NC	↔	
⑤	7	→ C	↔	OUT 4
	8	→ + NO	↔	
	9	→ NC	↔	
	10	→ C	↔	
	11	→ NO	↔	
⑥				COM 1
				Programming interface
	12	→ + 27 V DC		Digital inputs
	13	← IN		
⑦	14	→ ⊥ GND		
	15	→ + 27 V DC		
	16	← IN		
	17	→ ⊥ GND		
	18	← + IN		
⑧	19	← - IN		
	20	← + IN		
	21	← - IN		
	22	⊥ GND		DCW Interface
⑨	23	Signal B		
	24	Signal A		
	25	+ 27 V DC		

DCW Address	Function	FST	Factory setting	Digital inputs				Digital outputs					
				1	2	3	4	1	2	3	4		
	Secondary closing edge sensor 1			X									
	Secondary closing edge sensor 2				X								
	Main closing edge	3				X							
	Panic lock						X						
	Door status contact 1	3	"DOOR OPEN"					X					
	Door status contact 2	3	"DOOR CLOSED"						X				
	Door status contact 3	3	"ERROR"							X			
	Door status contact 4	3	Bell contact									X	
	Airlock pulse		Input (opening pulse)	X									
	Pharmacy pulse	3			X								
	Block airlock		Input (blocks the door)			X							
	Panic lock						X						
	Door status contact 5	3	Door closed					X					
	Door status contact 6		Block airlock output						X				
	Door status contact 7		Airlock pulse output							X			
	Door status contact 8	3	Bell contact									X	

Connection diagram night-bank opening via key switch KT 3 or card reader

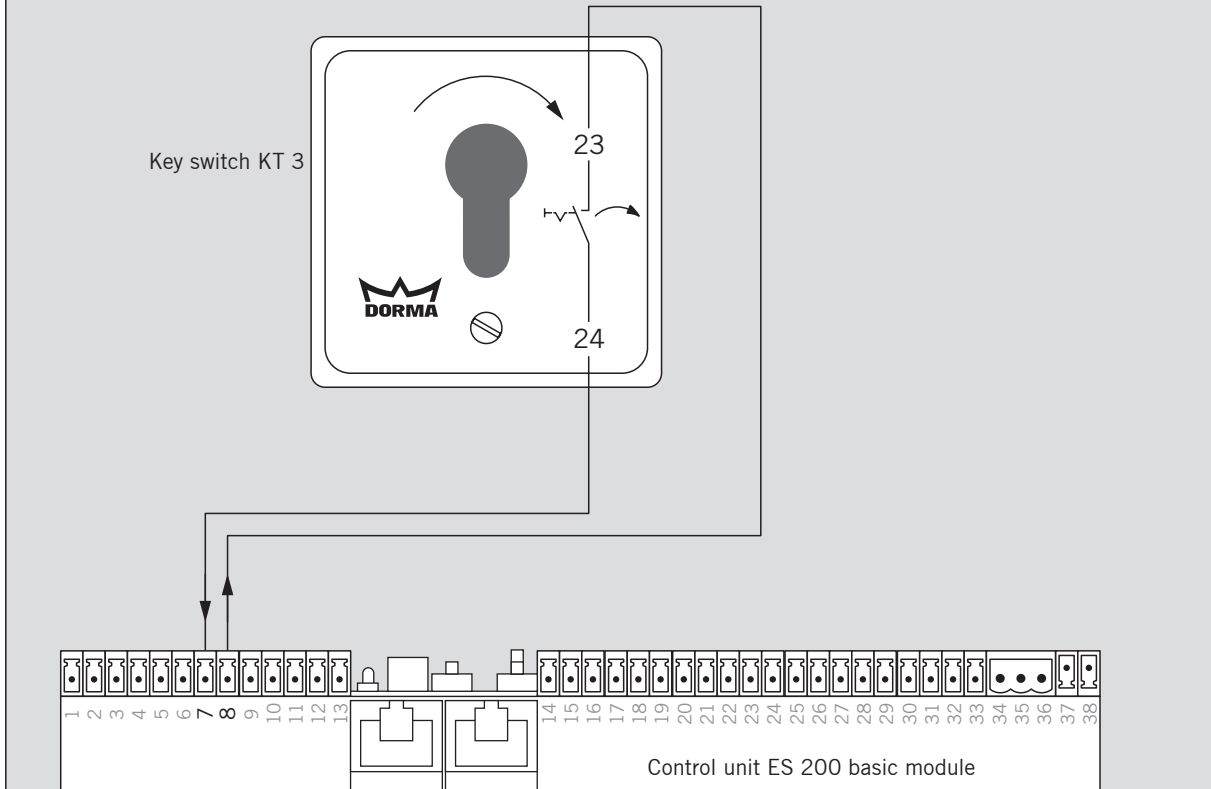

Connection diagram battery

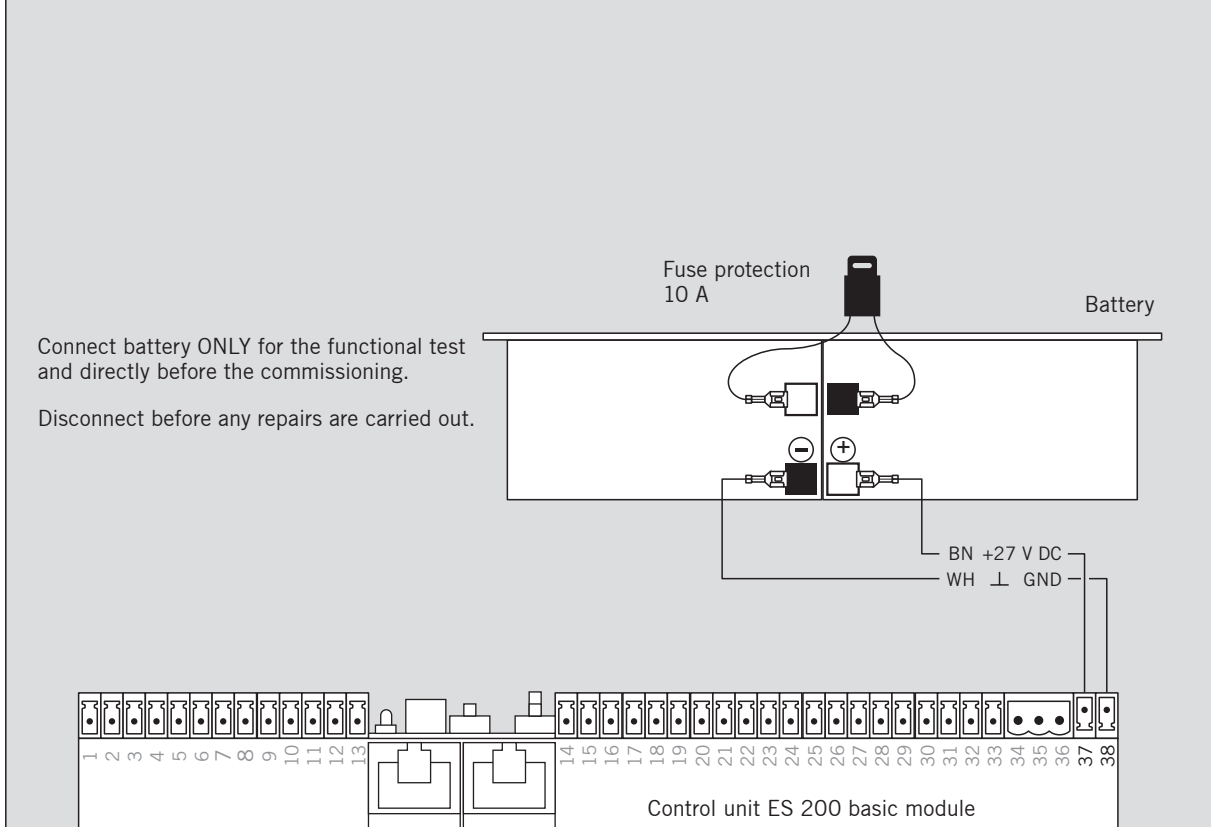

Connection diagram EMERGENCY STOP button (not for escape route systems)

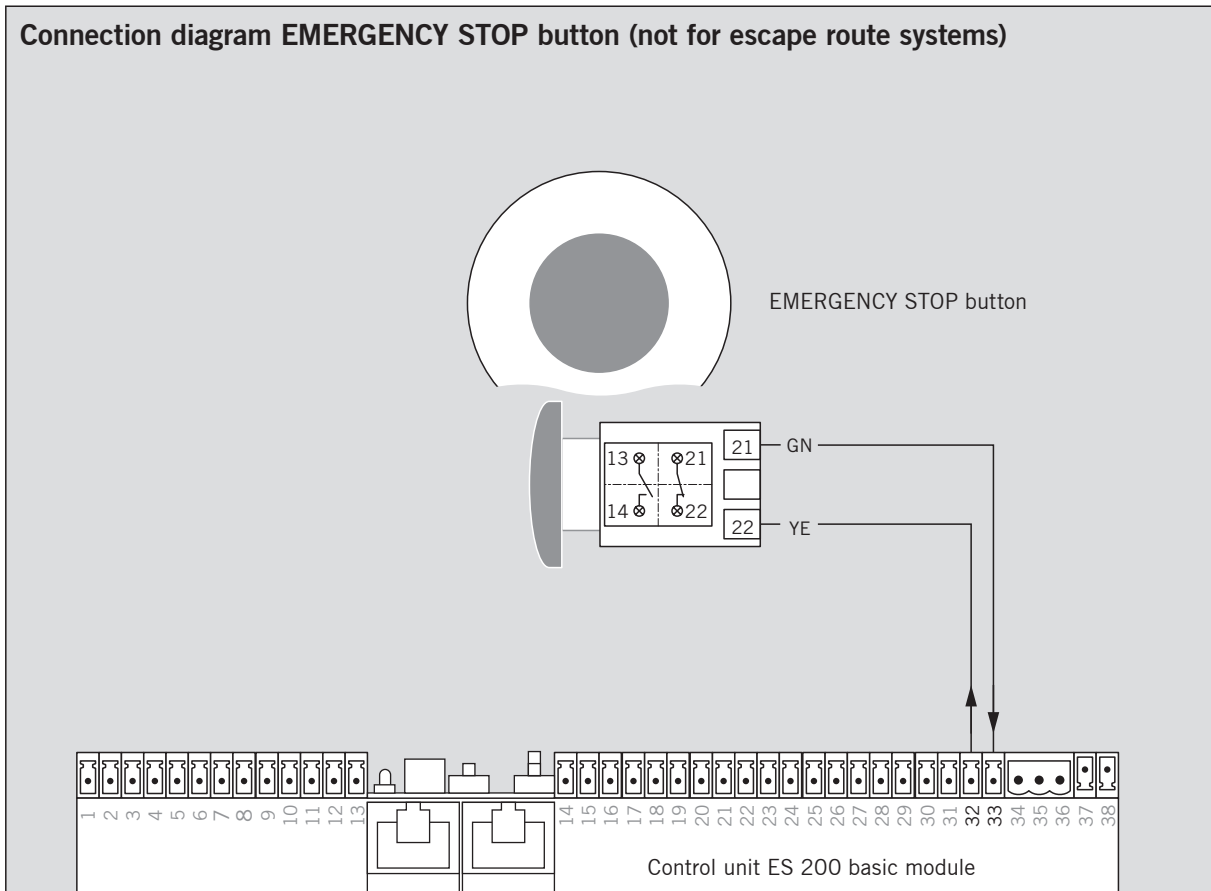

Connection diagram mechanical program switch

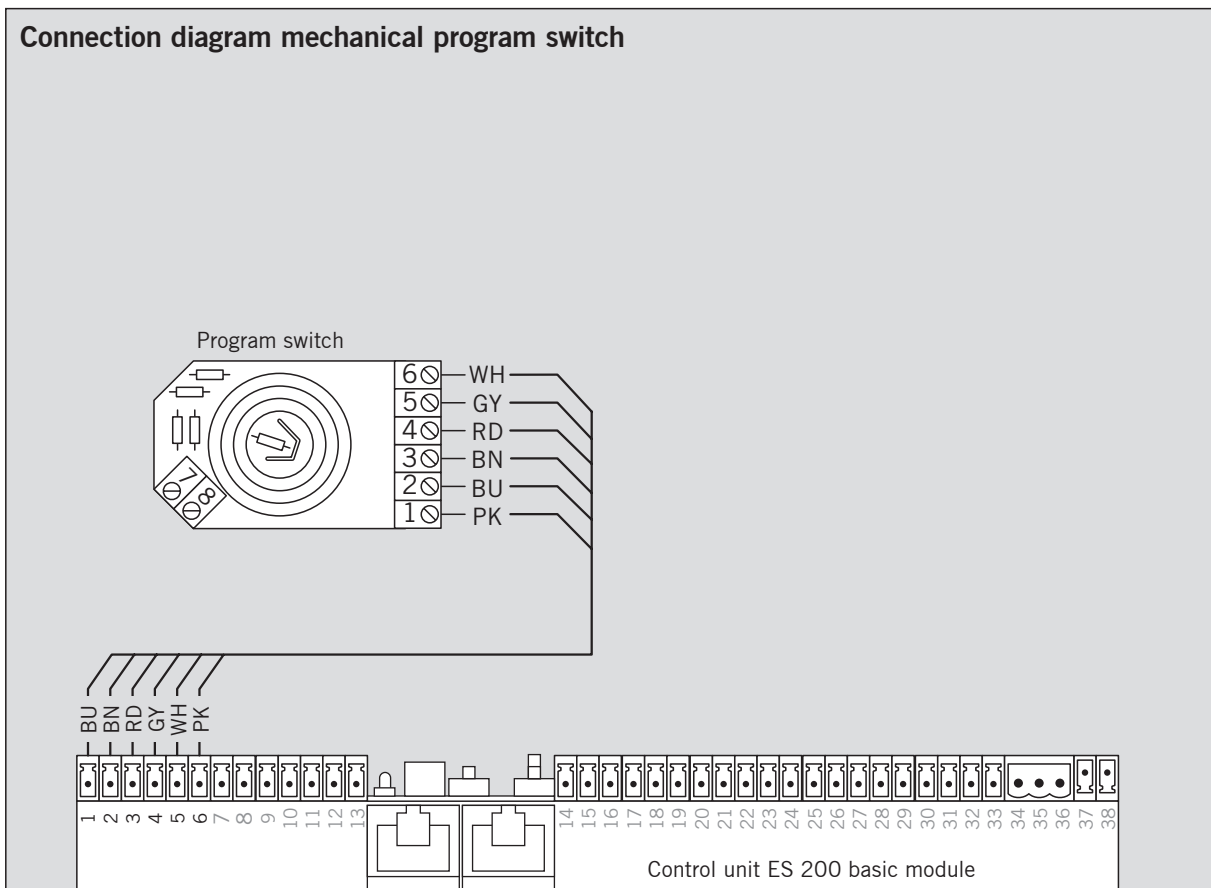

Connection diagram program switch EPS-S

Locking contact

- ☞ The locking contact is optional for doors that are not located along escape routes.
- ☞ In case of escape route systems, the locking contact is mandatory.

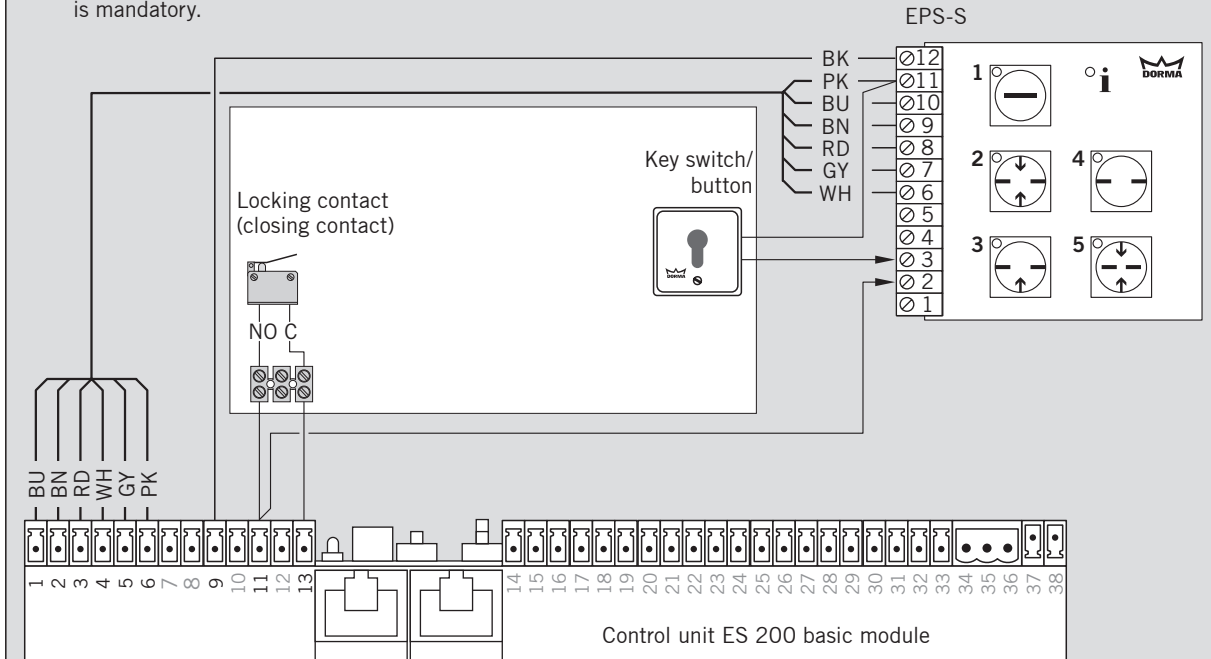

Connection diagram detector

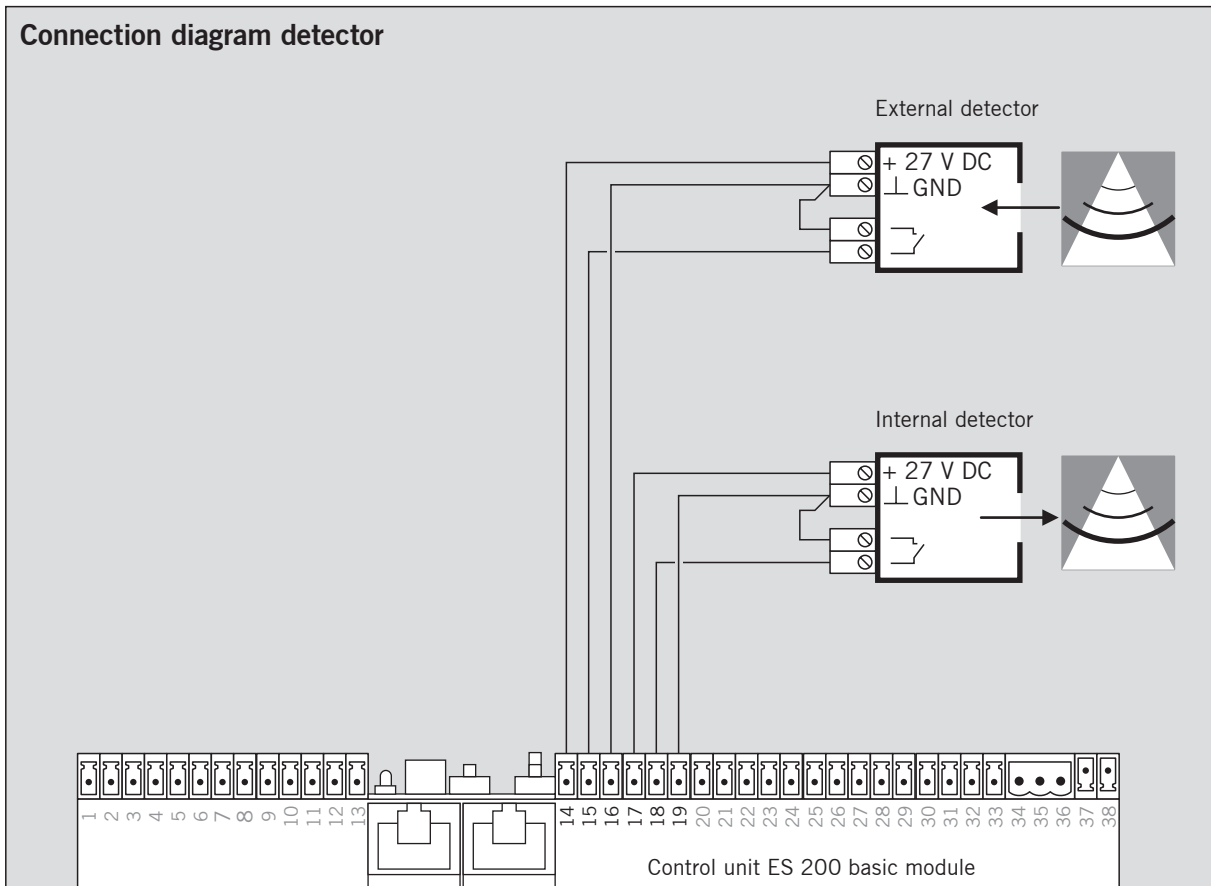

Connection diagram locking with response contact

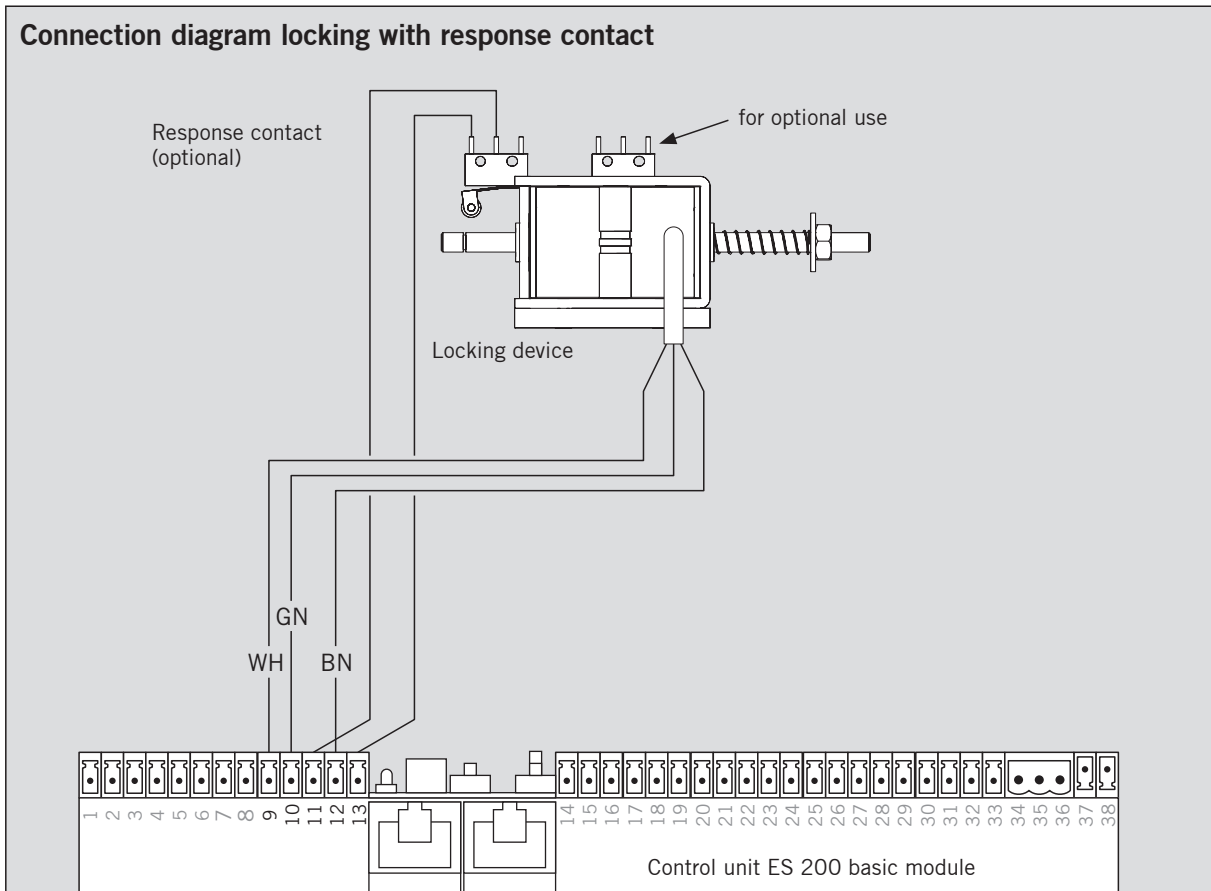

Connection diagram service display

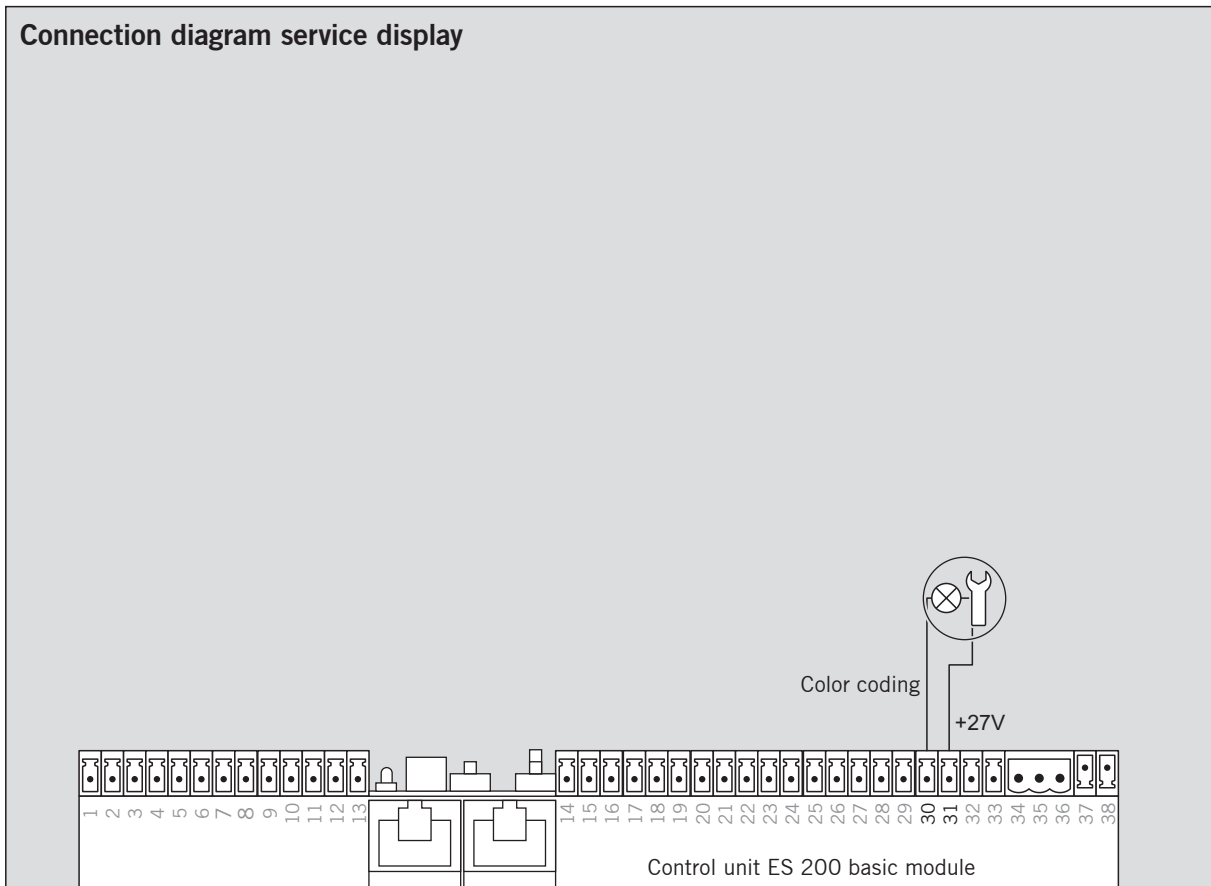

Connection diagram EMERGENCY STOP input (not for escape route systems)

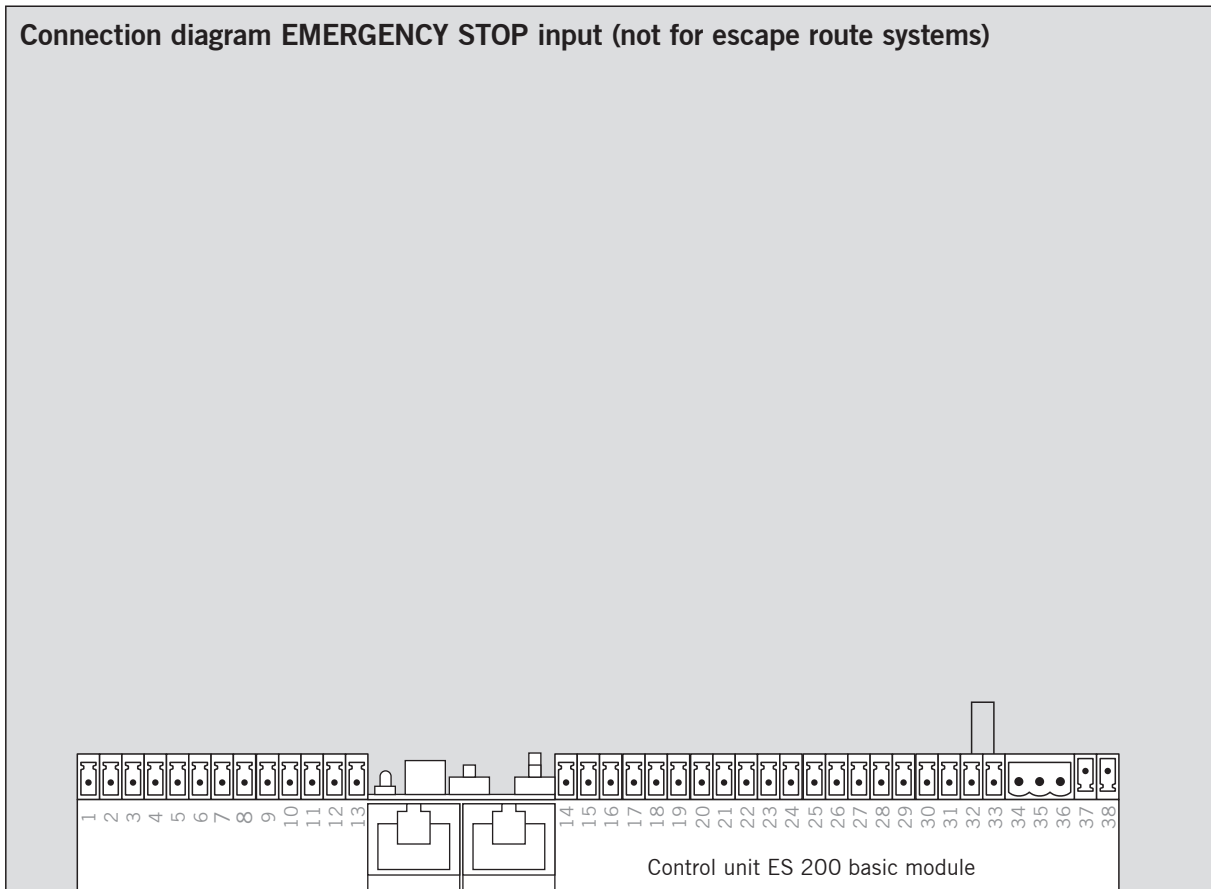

Connection diagram battery (FST module)

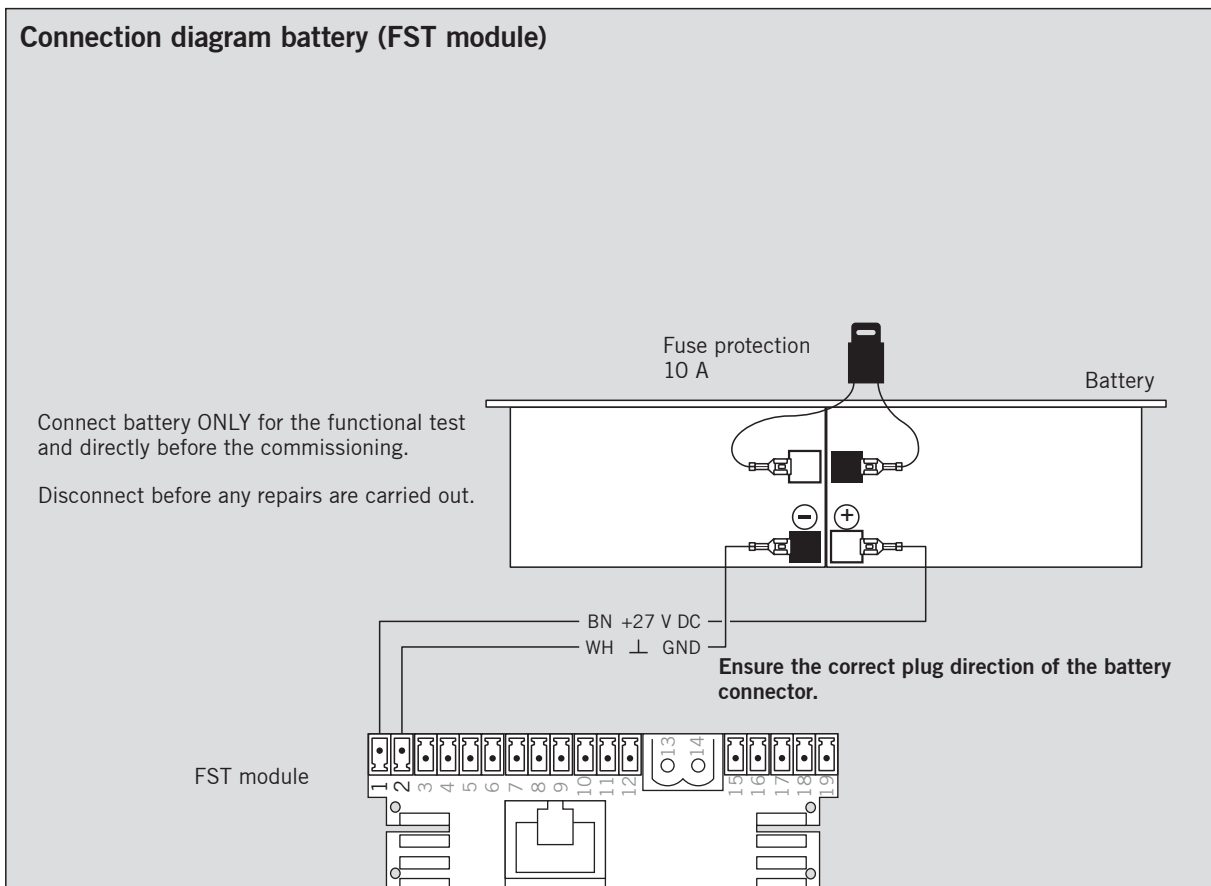

FFT FLEX GREEN / FFT FLEX GREEN 2D

Appendix

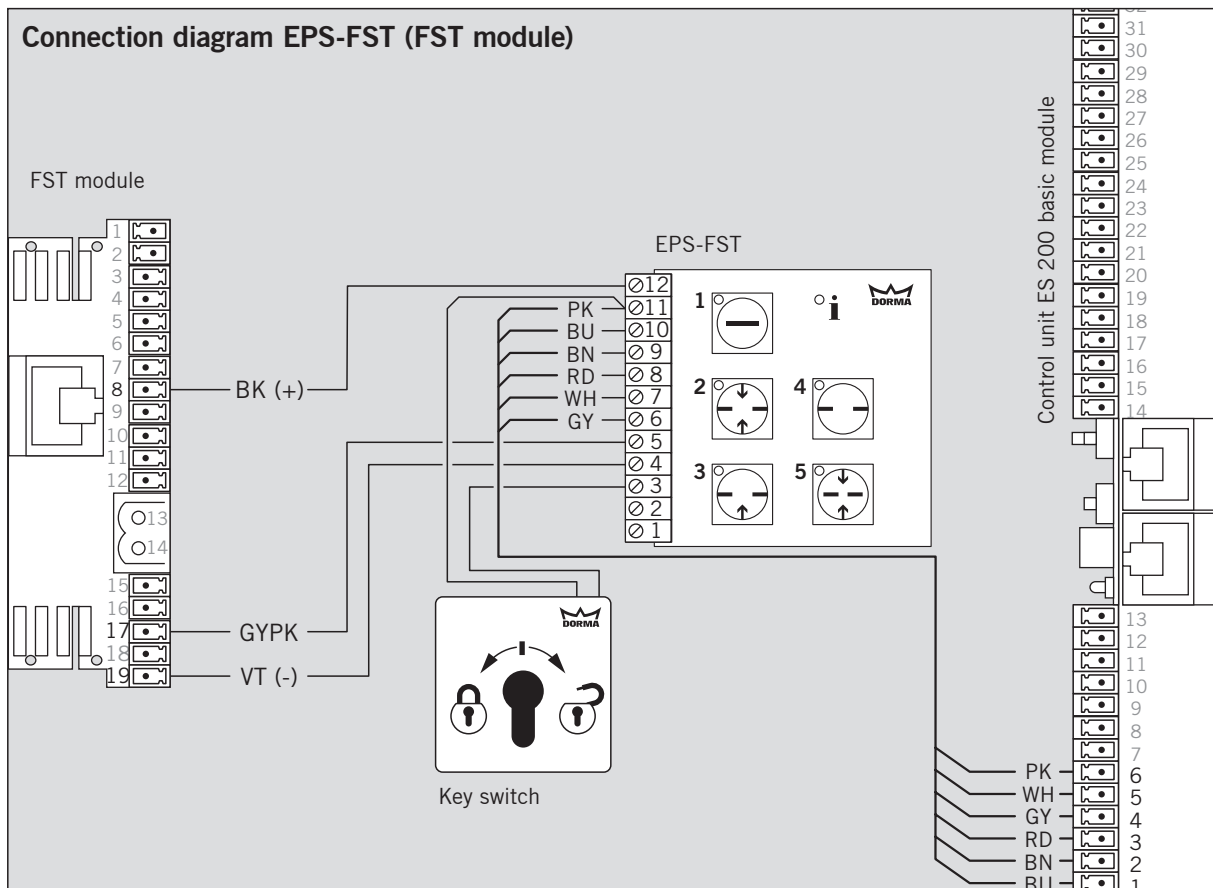
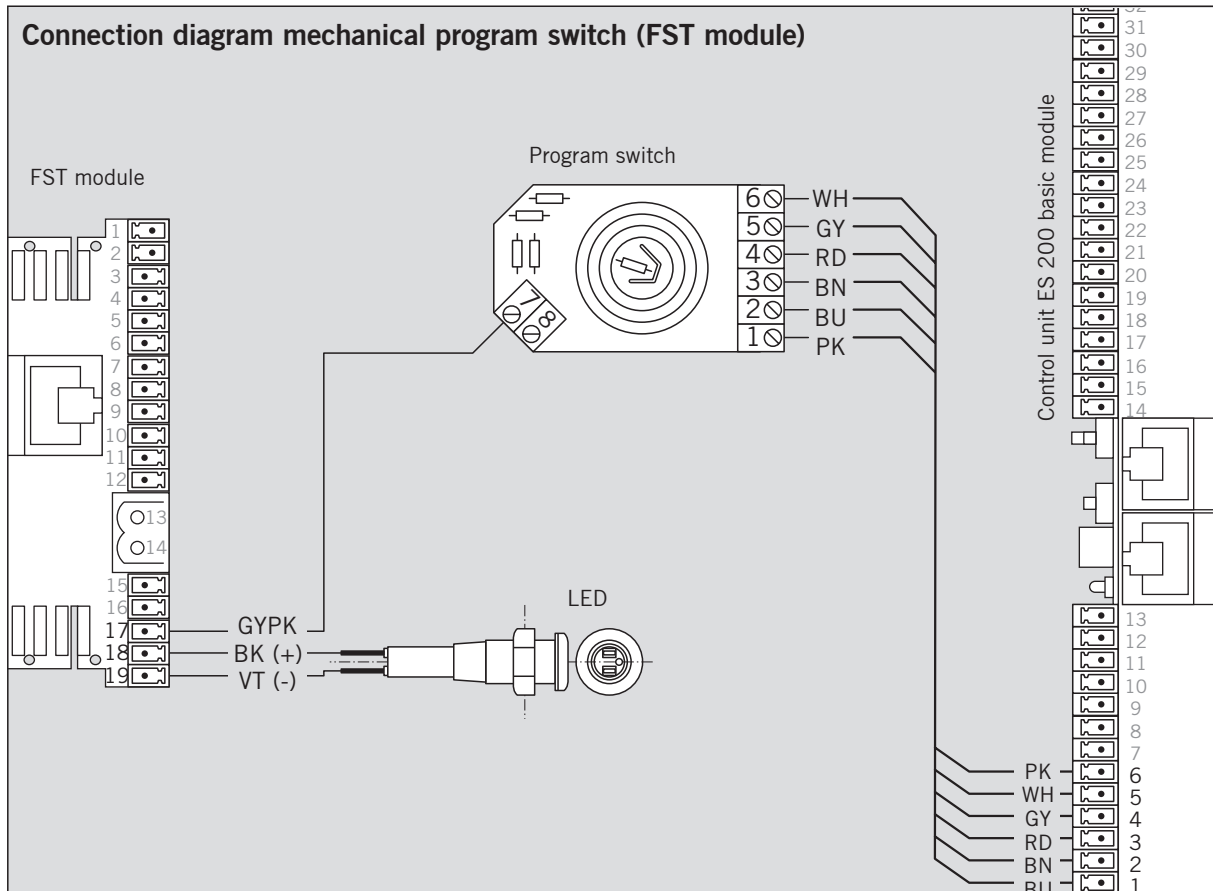

FFT FLEX GREEN / FFT FLEX GREEN 2D

Appendix

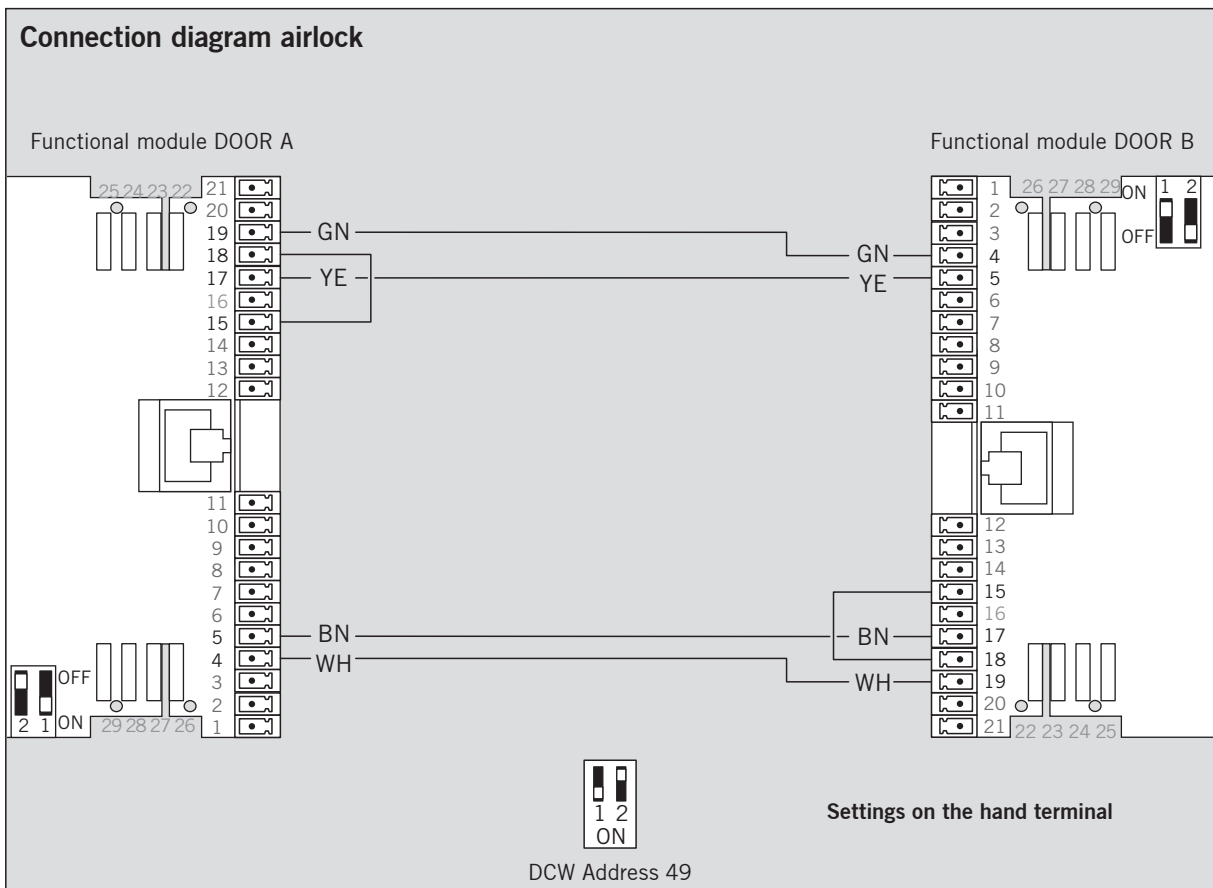
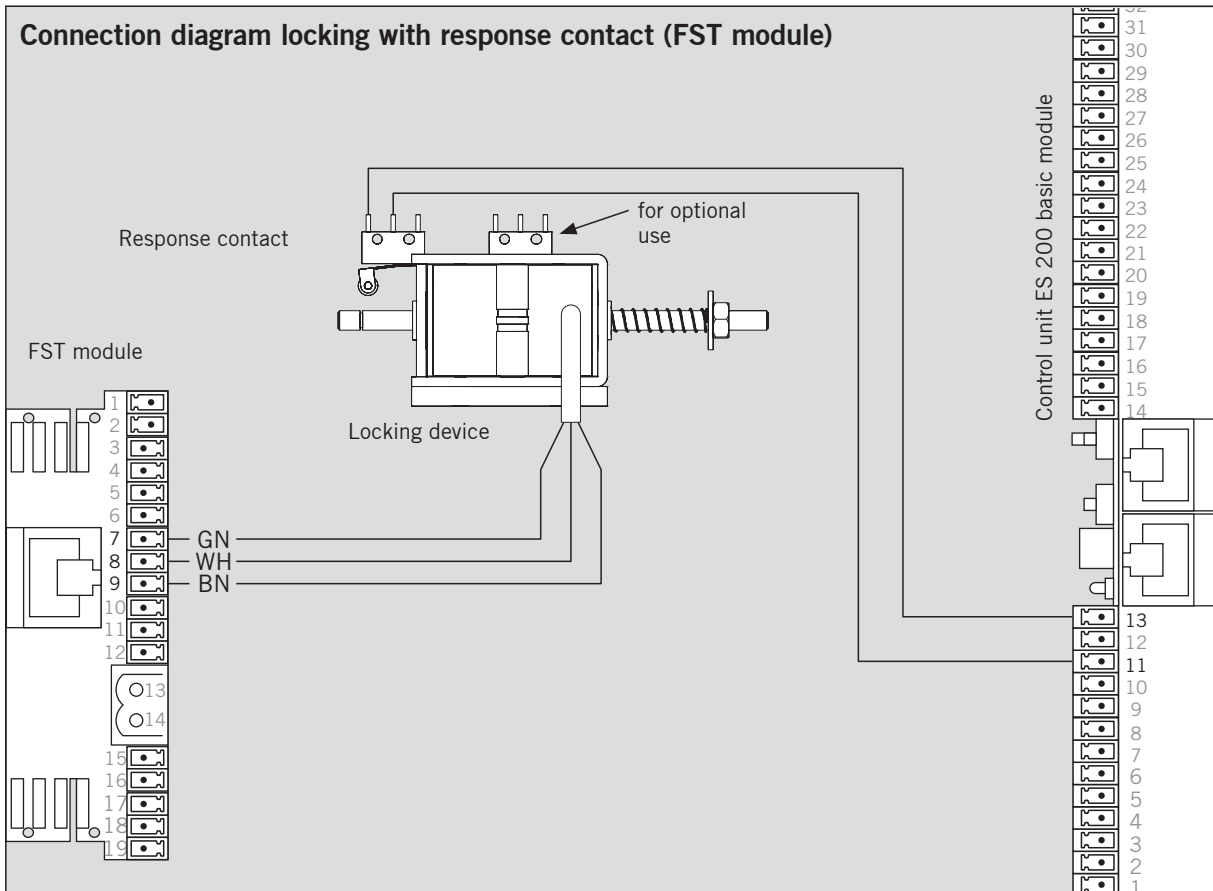

FFT FLEX GREEN / FFT FLEX GREEN 2D

Appendix

Connection diagram airlock with pulse relaying

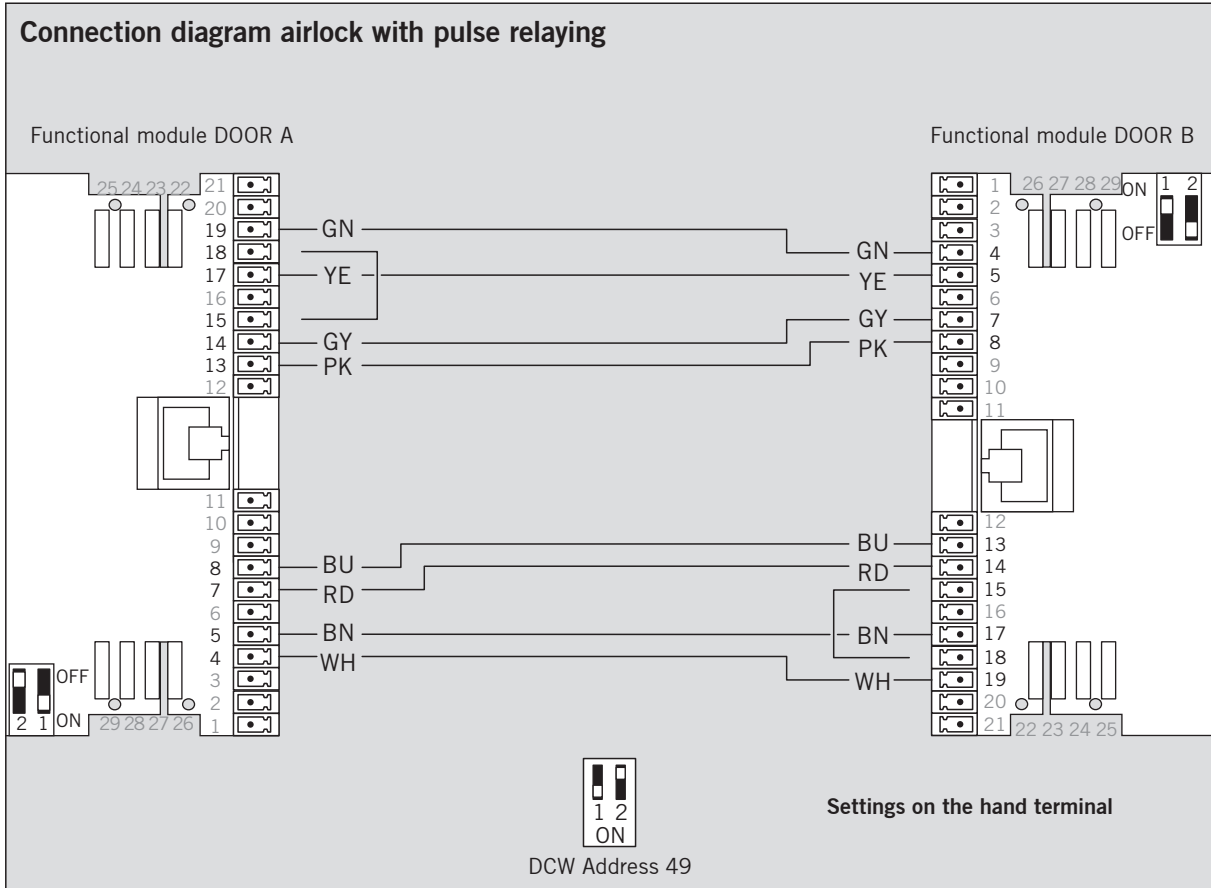

Connection diagram time airlock

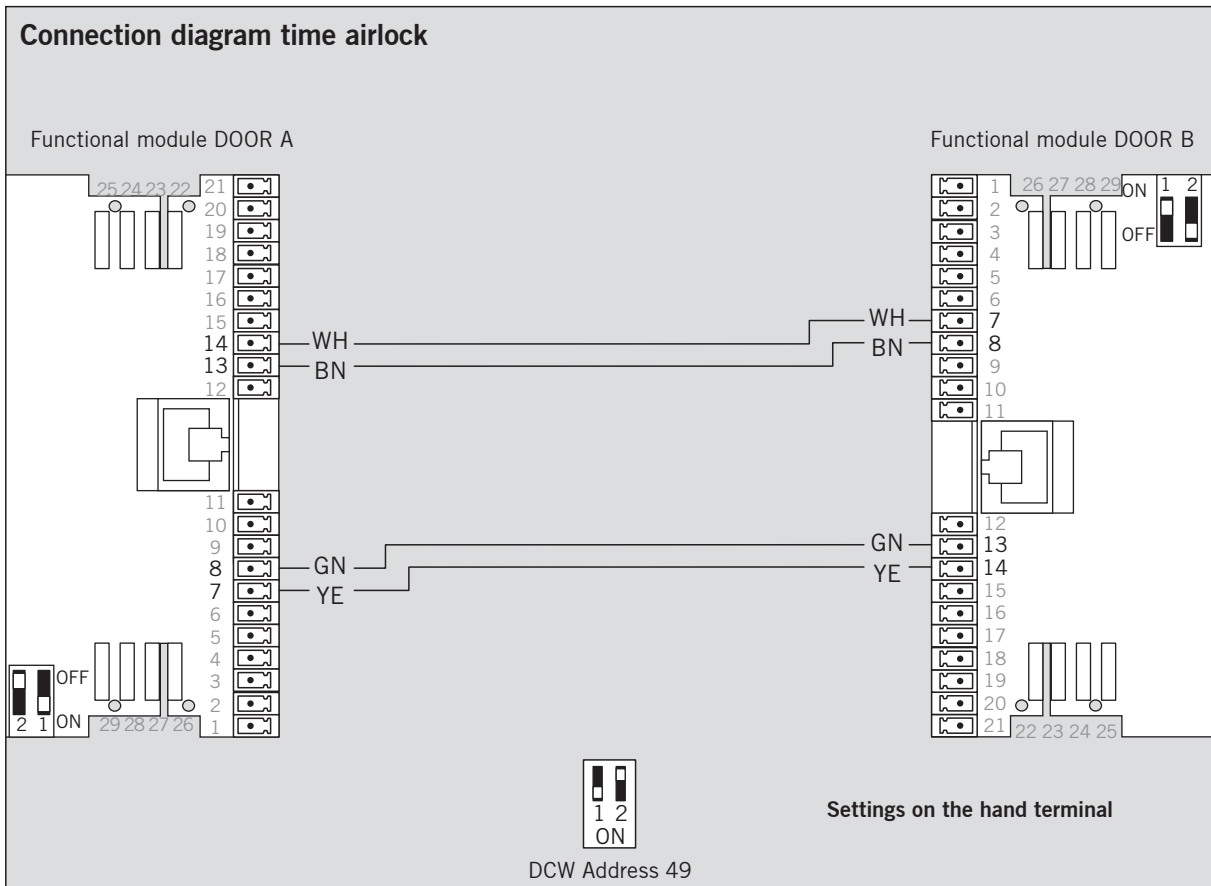

Connection plan panic lock

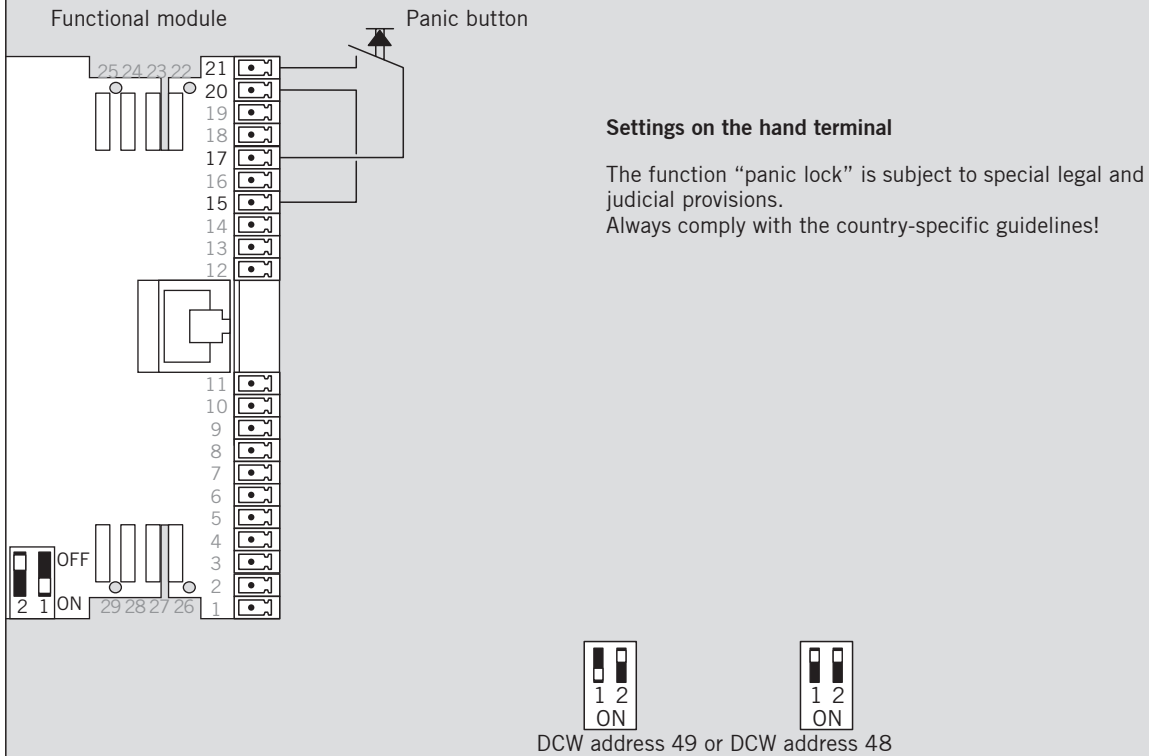



FFT FLEX GREEN / FFT FLEX GREEN 2D



FFT FLEX GREEN / FFT FLEX GREEN 2D



DORMA Deutschland GmbH
DORMA Platz 1
58256 ENNEPETAL
GERMANY
Phone +49 2333 793-0
Fax +49 2333 793-4950
www.dorma.com