

# Perimeter and Facility Access Hardware



## **SAFLOK Offers Premium Security**

In today's challenging world, having a building that is safe and secure is essential. SAFLOK<sup>™</sup>, a global leader in developing and manufacturing state-of-the-art access management solutions, offers a full range of door hardware and exit devices designed for securing high-traffic access areas anywhere around the property.

## Exit Device Hardware

SAFLOK™ offers a series of exit device hardware that is compatible with mechanical and electrical applications. This hardware is manufactured for the most demanding access/egress applications.

**Vertical Rod Exit Device:** The Advantex 20 series is a surface-mounted vertical rod exit device with a modern touch bar design.

**Rim Exit Device:** The Advantex 10 series is a single-point rim latch with a modern touch bar design.

### SAFLOK™ Panic Bar Locks, Combining the Best Features - Inside and Out

- Easy-to-install mechanical interface eliminates the need for an electrician
- No wires running through the door, frame, or hinges
- Self-contained battery allows up to 60,000 entries
- ANSI Grade 1 rating
- Auditable entries
- Auto latch/unlatch feature makes manual dogging unnecessary
- UL fire rated (optional)

SAFLOK electronic locks are compatible with most exit control devices. Contact your local sales representative for details.



## Advantex 10 Series Rim Exit Device Advantex 20 Series Vertical Rod Exit Device

**Hand:** Non-handed

**Stock:** 36" door width (standard);  
48" door width available at an upcharge

**Door types:** Wood, hollow metal,  
fiberglass, or aluminum

**Door requirements:**  
Fits standard 1 3/4" - 2 1/4" doors

**Mounting height:**  
40" above finished floor

**Stile width:**  
4 5/8" with standard 99 strike  
4 1/8" with optional 98 strike

**Latch bolts:** Stainless steel  
dead-locking; Pullman-type top latch

**Available finishes\*:**  
Bright Brass  
Satin Brass  
Bright Stainless Steel  
Satin Stainless Steel

Other panic bar  
options available.



### Available locks:



\*Check availability of finish for corresponding lock.

## Remote Control Unit

- RCU switch works with electrified locking devices
- Fits into double-gang, deep-back switch box
- Controls electric locking devices up to 24 volts AC/DC
- Auto latch/unlatch feature eliminates need for manual dogging in System 6000™
- Latch/unlatch keys accepted in both System 6000™ and DeskLinc™
- SPDT 5A@30VDC relay with common, normally open and normally closed contact
- Optional rain hood
- Messenger™ option requires plastic box

**Voltage:** 12-24 AC/DC

**Outside dimensions:**

4.65"W x 4.59"H

**Finishes:**

Dark Mahogany  
Satin Brass PVD  
Satin Stainless

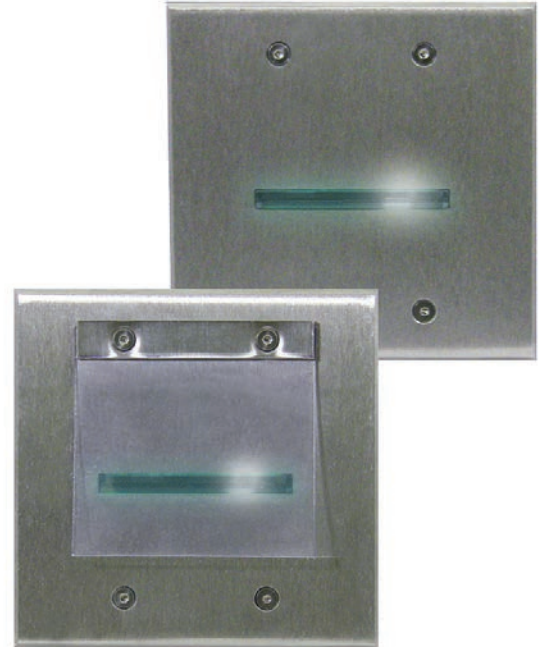

## Quantum™ RFID RCU

- RCU switch works with electrified locking devices
- Fits into double-gang switch box
- Controls electric locking devices up to 24 volts AC/DC
- Auto latch/unlatch feature eliminates need for manual dogging
- SPDT 5A@30VDC relay with common, normally open and normally closed contact

**Voltage:** 12-24 AC/DC

**Outside dimensions:**

4.56" W x 4.50" H x 0.75" D

**Plate finishes:**

Bright Brass  
Bright Chrome  
Satin Brass  
Satin Chrome  
Dark Oxidized



## Narrow Stile

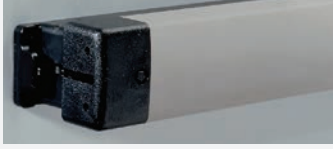

The narrow stile is designed to retract when electrical power is applied.

### Adams Rite 8800 Series

**Sizes:** 36" standard, (also 30", 42", and 48")

**Door requirements:** 1 3/4" standard, up to 2 1/4"

**Mounting height:** 40 1/4" from CL to finished floor

**Minimum stile:** 2"

**Available finish:** Satin Aluminum and Dark Mahogany

## Electric Strike



The electric strike is designed to release the door-locking mechanism when electrical power is applied. It works with mortise, rim, and cylindrical locks. Different models and sizes are available depending on the application. All models are fail-secure.

**Holding force:** 1,000 lbs.

**Voltage:** 24 VDC 1.5A

**Size:** 4 7/8", 7", or 11"

**Available finishes:** Satin Stainless and Dark Oxidized

## Electro-magnetic Lock



**Voltage:** 12 or 24 VDC (field-selectable)

**Magnet size:** 8 13/16" W x 2 13/16" H x 1 9/16" D  
(225mm x 56mm x 40mm)

**Armature size:** 9" W x 2 1/4" H x 1/2" D  
(230mm x 57mm x 14mm)

**Holding force:** 1,200 lbs.

**Available finishes:** Satin Aluminum and Dark Mahogany

SAFLOK™ offers an electro-magnetic locking device for perimeter doors. This locking unit provides over 1,200 pounds of locking force when activated. It is available in single- or double-magnet configurations.

## Motion Detector

When approaching the door the motion detector will automatically unlock, allowing entry. The unit's sensitivity is adjustable.



**Input power:** 12 or 24 VDC or VAC (field-selectable)

35 mA @ 12 VDC, 38 mA @ 24 VDC

38 mA avg. @12VAC, 45 mA avg. @24 VAC

**Relay:** Two Form "C" contact sets rated 1.0 amp @ 30 VDC maximum for DC-resistive loads

Temperature range: -20° to +120° F (-29° to +49° C).  
For UL-certified installations, the temperature range is 32° to 120° F (0° to 49° C.)

Refer to installation guide.

**Enclosure:** 6 1/4" W x 1 1/2" H x 1 1/2" D  
(158mm x 38mm x 38mm)

## Exit Button

The exit button is a palm-sized button designed to deactivate electronic locking devices. It is used for manual egress and works in conjunction with other types of entry/exit devices.



## Touch Bar Exit Device

The touch bar exit device is ideally suited to allow manual egress of electro-magnetic locks, remote alarms, and other security devices. The touch bar comes in a kit, which includes the touch bar, a wire loop and pull handle. See application diagrams on pages 5 and 6.

**SPDT rated:** 5A, 250 VAC

**Available finishes:** Satin Aluminum and Dark Mahogany



## Intercom

The intercom system allows communication with anyone trying to gain entry through the perimeter doors. It comes with an intercom base, speaker with call button, and a power supply. It also allows remote entry depending on perimeter hardware currently in use.

**Power source:** AC 12 - 16V or DC 12 - 24V

**Consumption:** Max. 4W (AC 16V), Max. 200 mA (DC 24V)

**Calling:** Electronic continuous tone (from door to master)  
Electronic continuous tone or voice (from master to door)

**Output:** 100 mW

**Wiring:** Two non-polarized wires and two wires for door release

Contact capacity for door release:

Max. AC 30V, 1A, Max. DC 30V, 1A

**Distance:** 390' (24 AWG), 650' (22 AWG), 980' (20 AWG),  
1,570' (18 AWG), 2,360' (16 AWG)

**Dimensions:** 5 1/2" W x 7" H x 2 1/4" D  
(143mm x 180mm x 55mm)



## Suggested Applications

### Active Double Doors

#### Magnetic locks with touch bars

- KIT Components:
- One power supply
  - Two magnetic locks
  - Two touch bars (inside)
  - Remote control unit (outside)

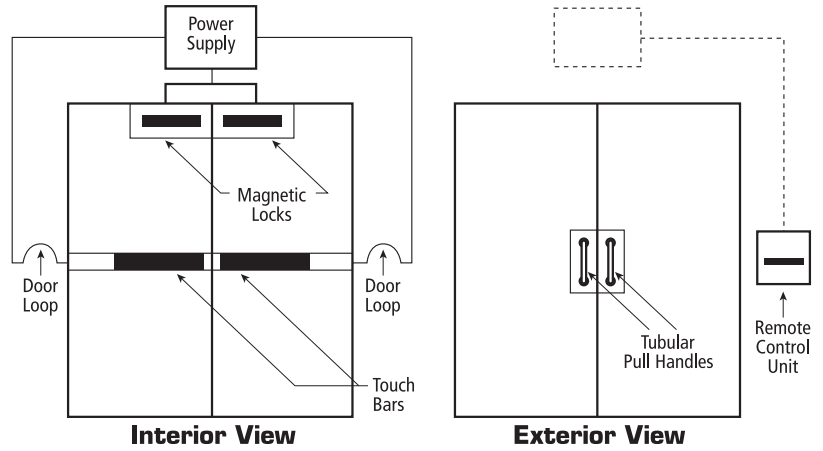

#### Magnetic locks with motion sensor and exit button

- KIT Components:
- One power supply
  - Two magnetic locks
  - Exit button (inside)
  - Motion sensor (inside)
  - Remote control unit (outside)

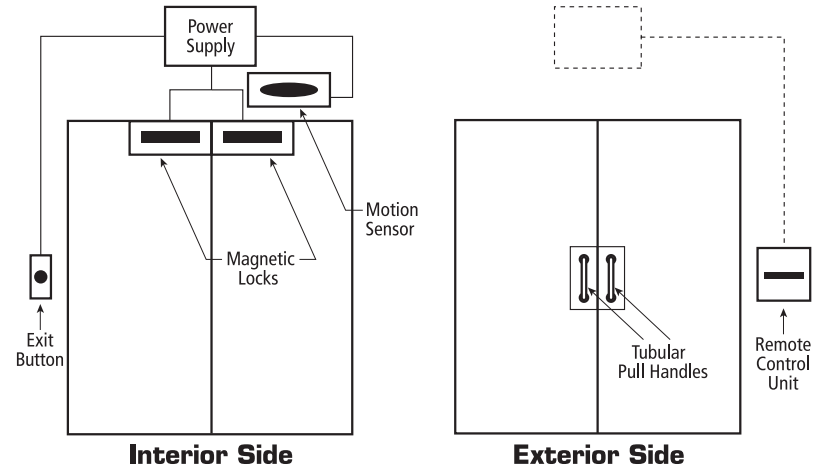

### Double Doors with One Active

#### Magnetic locks with touch bar

- KIT Components:
- One power supply
  - One magnetic lock
  - One touch bar (inside)
  - Remote control unit (outside)

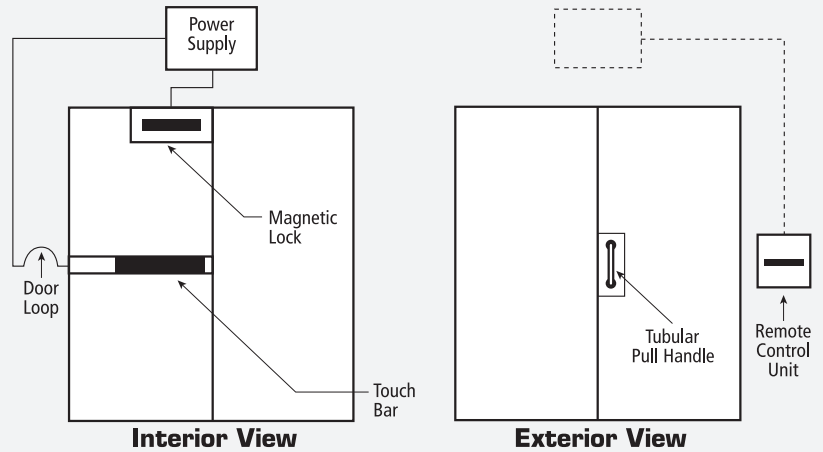

#### Magnetic locks with motion sensor and exit button

- KIT Components:
- One power supply
  - One magnetic lock
  - Exit button (inside)
  - Motion sensor (inside)
  - Remote control unit (outside)

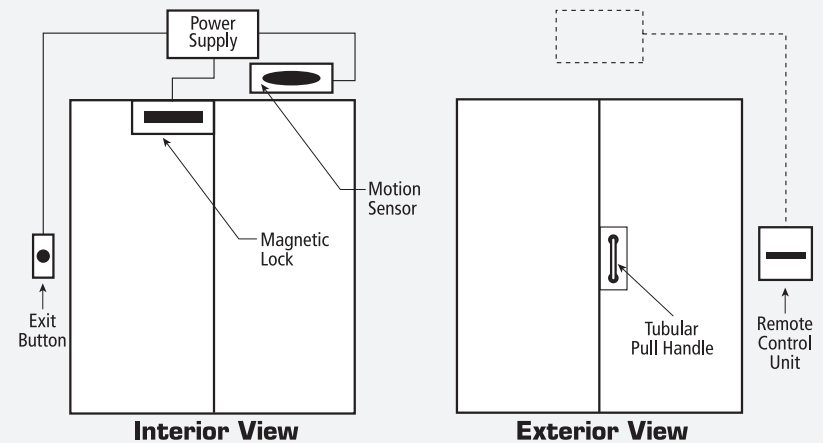



# Single Door Magnetic Locks with Different Egress Devices

## Magnetic lock with motion sensor and exit button

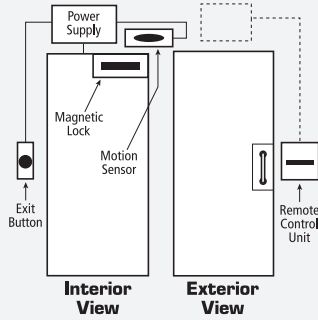

**Components:**

- One power supply
- One magnetic lock
- Exit button (inside)
- Motion sensor (inside)
- Remote control unit (outside)

## Magnetic lock with touch bar

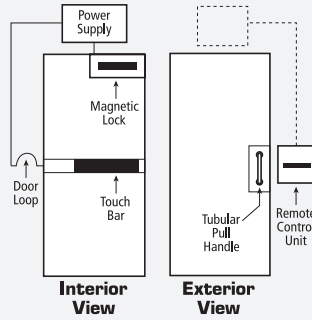

**Components:**

- One power supply
- One magnetic lock
- One touch bar (inside)
- Remote control unit (outside)

## Electric strike

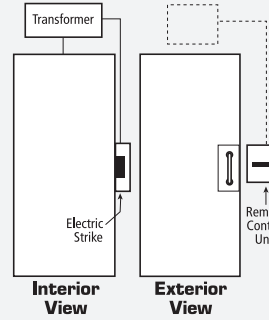

**Components:**

- One transformer
- One electric strike
- Remote control unit (outside)

## Narrow stile

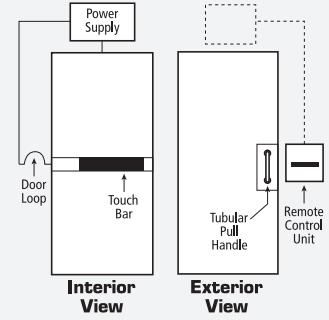

**Components:**

- One power supply
- One electrified panic bar (inside)
- Remote control unit (outside)
- Door loop

## Rim Exit Device

- KIT Components:**
- Mounting plate
  - Mounting hardware
  - SAFLOKTM rim panic lock

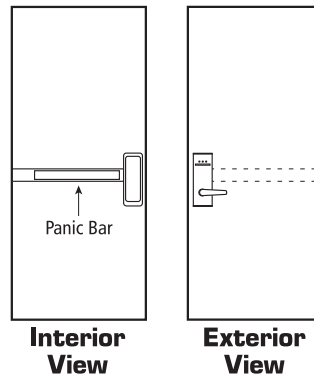

## Vertical Rod Exit Device

- KIT Components:**
- Mounting plate
  - Mounting hardware
  - SAFLOKTM vertical rod panic lock

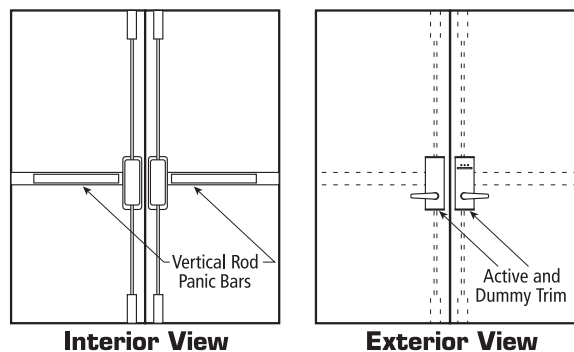

## Elevator Control

SAFLOK™ offers an elevator control unit (ECU) and a multi-channel elevator control unit (MCECU). The standard elevator control unit uses a single relay that will control access to certain floors.

The MCECU's most distinctive feature is that it enables up to 12 pass levels (secure stops), while a standard RCU and ECU can only be programmed to permit a single pass level. The MCECU card reader can be installed on each elevator and is connected to a box containing a processor circuit with up to 12 relays on it.

When a card having one or more pass levels on it is read, the appropriate relay(s) will switch to allow recognition of the floor buttons that each one controls.

All this translates into greater access control. Keycards can be encoded to grant access to only one of the controlled floors, all the controlled floors, or any combination in between the 12 passes.



## MCECU Control Room Option

While standard serial communication is generally limited to a distance of 15 feet, the control room option allows the controls to be placed in a separate elevator control room, not the car itself. To communicate between the control room and the elevator car, the device converts serial TTL communication to RS422 communication. The property is responsible for supplying and installing the cable.

## Expanded Pass Option

For properties that require more than the standard 12-pass levels (secure stops) with the MCECU, the expanded pass option is expandable up to 256 new elevator pass levels for a given site. Each new MCECU panel has 16 pass options, and multiple panels that can be used together. This feature is available with the Quantum™ RFID ECU only.