

A technical line drawing of a multi-pane window system, likely a sliding door or large window. It shows four vertical panes with visible hinges and locking mechanisms. The drawing is rendered in black lines on a light gray background.

HSW FLEX THERM

Mounting instructions

Content

1 About these mounting instructions.....	4
1.1 Information about these mounting instructions	4
1.2 Supporting documents	4
1.3 Copyright	4
2 Safety	4
2.1 Intended use	4
2.2 Personal protective equipment	4
2.3 Personnel qualification	4
3 Overview HSW FLEX Therm	5
3.1 Example.....	5
3.2 Scope of delivery	5
3.3 Roller.....	6
4 Assembly	6
4.1 Preparing the assembly.....	6
4.2 Mounting the tracks	7
4.3 Mounting the wall mounting profiles	8
4.4 Mounting the bottom rail	8
4.5 Mounting the fixed panel	8
4.6 Mounting the single action door.....	9
4.7 Mounting the panels.....	10
4.8 Aligning the panels.....	11
4.9 Mounting the lower locking device	12
4.10 Adjusting the upper locking devices	12
4.11 Inserting glass panels	13
4.12 Mounting the door handles.....	15
4.13 Adjusting the locking plates	15
4.14 Mounting the track cover	15
4.15 Adjusting the brush seals.....	16
4.16 Final inspection	16
4.17 Replacing the brush seals	16
5 Maintenance	18
6 Troubleshooting	18

1 About these mounting instructions

1.1 Information about these mounting instructions

These mounting instructions allow for the safe assembly of the horizontal sliding wall HSW FLEX Therm. The mounting instructions are part of the HSW FLEX Therm and must be kept accessible to you at all times. In case of a loss, you can download the current version of the mounting instructions at www.dormakaba.com. The personnel must carefully read and understand these mounting instructions prior to the beginning of the work. Safe working conditions require that all safety instructions and directions given in these mounting instructions are followed. In addition, the local health and safety regulations as well as safety regulations apply to the use of the HSW FLEX Therm.

1.2 Supporting documents

In addition to these mounting instructions, please consider the following documents:

- Operating manual HSW FLEX Therm
- System drawing for the delivered system
- Mounting instructions provided by the suppliers
- Glazing instructions provided by the glass manufacturers

1.3 Copyright

The contents of these mounting instructions are protected by copyright. Its use for the HSW FLEX Therm is permitted. Any use beyond this requires the written consent of dormakaba Deutschland GmbH.

2 Safety

2.1 Intended use

The horizontal sliding wall HSW FLEX Therm is used exclusively as a sliding wall partition for indoors and outdoors.

- ☞ The HSW FLEX Therm may not be used as an escape or panic door.
- ☞ The HSW FLEX Therm is not completely sealed and may therefore not be used in cold stores.
- ☞ The HSW FLEX Therm is not suitable for rooms in which chemicals (e.g. chlorine) are used.

2.1.1 Hazards during the assembly



WARNING!

Crushing hazard during the hinging and unhinging of the doors and panels!

- Exercise caution.
- Carry out the work with two people.



WARNING!

Risk of falling and injury when working at great heights!

- Use a suitable fall protection.
- Use climbing aids with a sufficient carrying capacity.
- Ensure a secure foothold and hold.



WARNING!

Risk of injury due to falling components or tools!

- Secure tools to prevent them from falling down.
- Lift heavy components with two persons.
- Wear a safety helmet.

2.2 Personal protective equipment

- Safety goggles for protecting the eyes against drilling chips and glass splinters flying around.
- Safety shoes for protecting the feet against bruising, falling parts and slipping on slippery ground.
- Protective gloves for protecting the hands against abrasions and cuts caused by glass.
- Industrial safety helmets for protecting the head against falling objects, swinging loads and running into fixed objects.

2.3 Personnel qualification

Qualified technician

The technician has been trained and instructed by dormakaba.

His professional training, knowledge and experience allows him to carry out the assembly of the HSW FLEX Therm.

He knows the relevant standards and regulations.

He also has knowledge and experience in the following areas:

- Occupational safety, operational safety and accident prevention regulations
- Handling of ladders and scaffolds
- Handling and transport of long, heavy parts
- Assembly of glass panels
- Handling of tools and machines
- Use of fastening elements
- Evaluation of the building fabric

Maintenance personnel

Due to its professional training, knowledge and experience, the maintenance personnel is able to carry out maintenance work on the HSW FLEX Therm and independently identify and prevent possible hazards.

Required tools

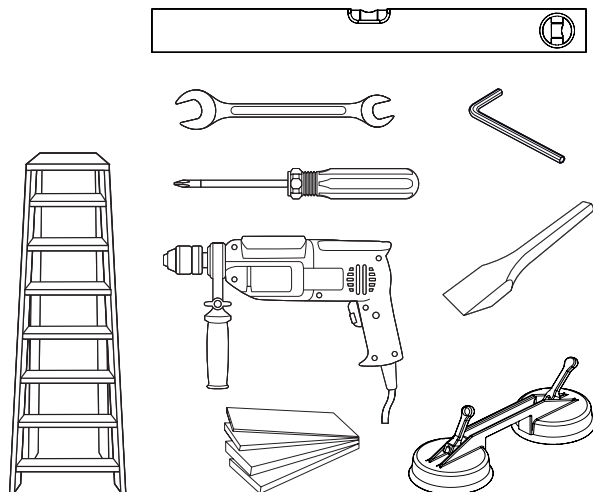

3 Overview HSW FLEX Therm

3.1 Example

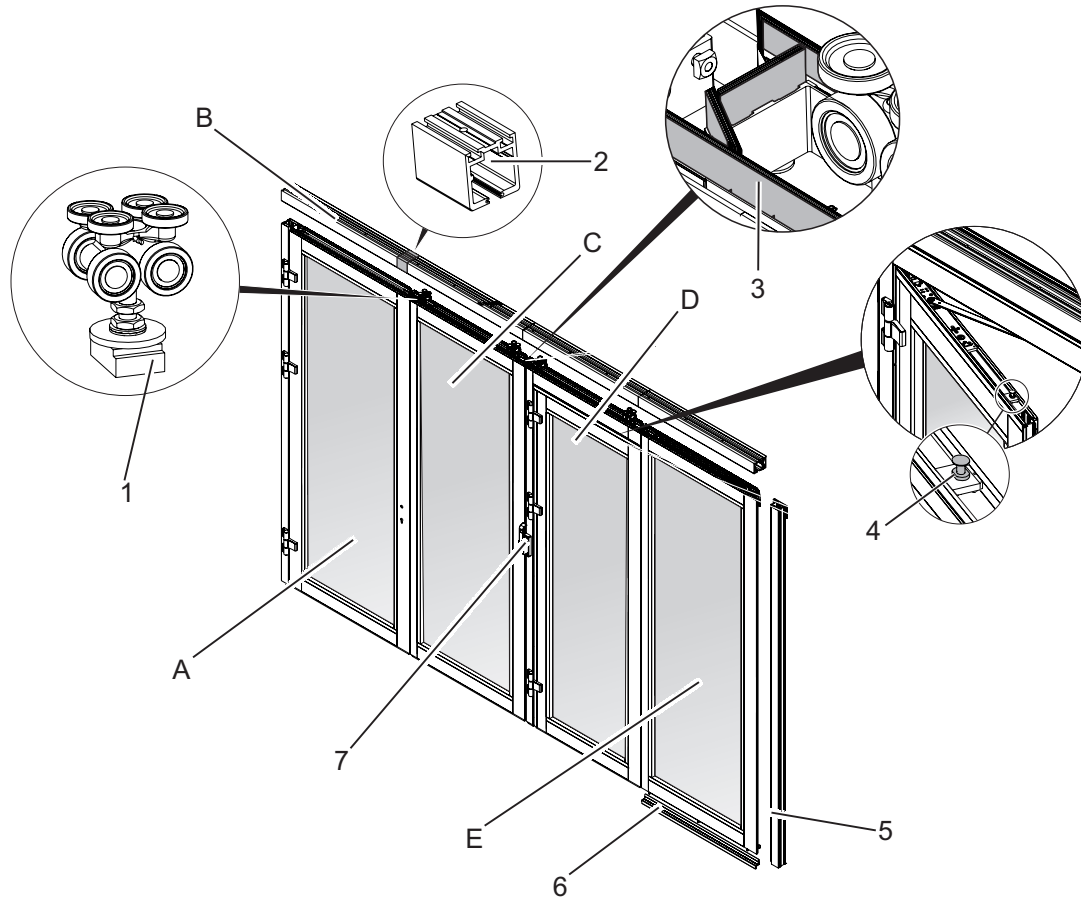

Fig. 1: Exemplary assembly

The HSW FLEX Therm is a horizontal sliding wall, which basically consists of the following main components:

- A Pivoting end panel
- B Track
- C Sliding panel
- D Single action sliding panel
- E Fixed panel
- F Customized stacking area (not shown in Fig. 1)

Other HSW FLEX Therm components:

- 1 Rollers (guide the panels through the track)
- 2 Revision piece
- 3 Brush seal
- 4 Mushroom head
- 5 Wall mounting profile
- 6 Bottom rail
- 7 Door lock bar

3.2 Scope of delivery

The standard scope of delivery includes the following components:

- Tracks incl. stacking area with fastening screws
- Panel with roller and doors, complete (without glazing)
- Wall mounting profiles
- Eccentric bushings for locking bolt on the floor
- ☞ Other mounting material for different building fabrics is not included in the scope of delivery.
- ☞ The actual scope of delivery is shown on the delivery note.

3.3 Roller

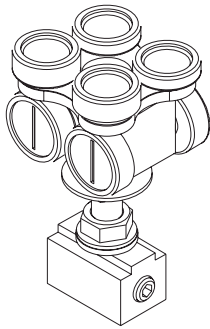

Fig. 2: T-roller

T-roller:

Tandem roller for all self guiding stacking areas. The T-roller is the standard roller.

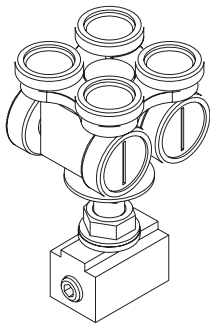

Fig. 3: TN-roller

TN-roller:

Tandem roller (with four low rollers). The TN-roller is used for reshuffle bypass module when parking in niches.

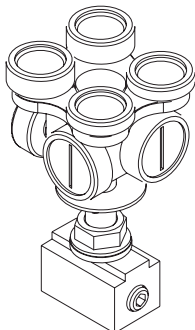

Fig. 4: K-roller:

K-roller:

Cross roller for 90° branches in combination with T-pieces and angles

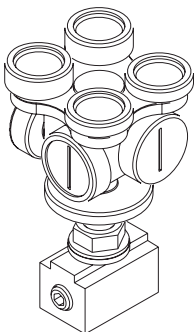

Fig. 5: KU-roller

KU-roller:

Cross roller with deviation support, as roller K but with turning aid.

4 Assembly

Sequence of assembly

Please be sure to follow the sequence of the assembly. Otherwise, it may cause problems with the operation of the system.

1. Check the clear width and clear height and compare it with the system drawing.
2. If all dimensions are conform, mount the substructure, the track and the stacking area.
Should there be any deviations of the clear width, then reduce or increase the gap between the panels (5 mm).
3. Mount the wall mounting profile (pivoting end panel and fixed panel).
4. Mount the bottom rail if a fixed panel is provided for the system.
5. Connect the wall mounting profiles to the pivoting end panel via the hinges (hinges are already pre-adjusted to a 5 mm gap). If necessary, adjust the height via the hinges.
6. Block pivoting end panel according to the glazing directive. Clamp the glass clamping profile and position the seals.
7. Open the pivoting end panel and insert all panels in sequence into the track.
8. Insert all panels into the stacking area. Adjust the positions of the rollers. Begin with the connection panel directly next to the pivoting end panel.
9. Move all panels into the front. Adjust the panel height using the rollers. Begin with the connection panel directly next to the pivoting end panel. If needed, also adjust the pivoting end panels via the door hinges.
10. Check the gap between the panels.
Mark the bolt positions on the floor and drill. Mount the eccentric bushings.
11. Check the function if a single action sliding panel is provided for the system. If necessary, make adjustments.
12. Block all panels in accordance with the glazing directive. Clamp the glass clamping profiles and position the seals.

4.1 Preparing the assembly

☞ The assembly requires at least two qualified technicians.

1. Compare the scope of delivery with the delivery note.
2. For the assembly of the HSW FLEX Therm, measure provided openings (including the park position in the stacking area) and check for compliance with the system drawing.
3. Make sure that the provided mounting surfaces for the tracks and the wall mounting profiles as well as the floor are even and horizontal or vertical.
4. Depending on the building fabric, select suitable mounting material (screws, wall plugs etc.) for the assembly of the track and wall mounting profiles.
☞ Use stainless steel screws for the outside in order to prevent corrosion.
5. Keep glass panels ready for the installation.

4.2 Mounting the tracks

- ☞ Depending on the building fabric, a substructure (e.g. dormakaba UK system) has to be mounted across the entire length prior to the assembly of the tracks and the stacking area. Alternatively, a suspended assembly of the tracks with threaded pins is possible.
- ☞ If a substructure is used, boreholes with the corresponding bore distances must be available for the mounting of the tracks.
- ☞ The revision piece (Fig. 6/1) is part of the entire length of the tracks. Do not yet connect the revision piece as it will be removed again during the course of the assembly. The exact position of the revision piece is specified on the supplied system drawing.

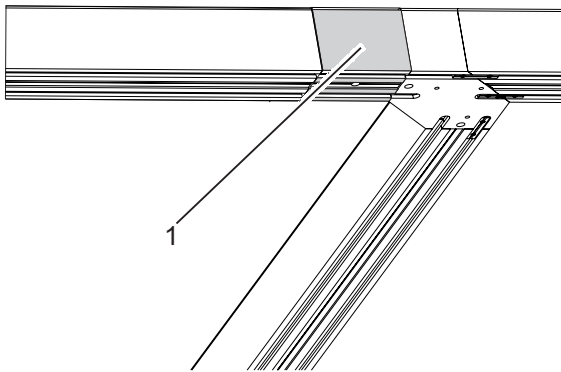

Fig. 6: Position of the revision piece directly in front of the stacking area

1. If required, mount a suitable substructure or suspension.
2. Get the tracks ready in accordance with the system drawing.

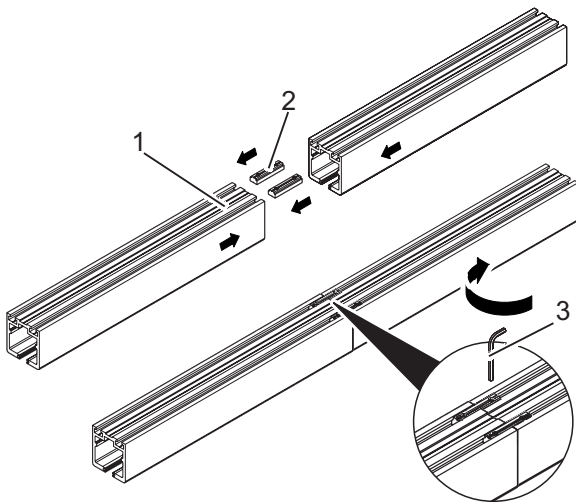

Fig. 7: Mounting the tracks

3. Connect the tracks (Fig. 7/1) using connecting elements (Fig. 7/2) on the floor.
 - ☞ The connecting elements will be no longer accessible if the tracks are mounted to a substructure without threaded rods.
4. Use a 3 mm socket head wrench (Fig. 7/3) to tighten the locking screws of the connecting elements.

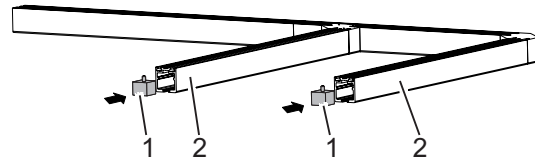

Fig. 8: Mounting the end stop

- ☞ End stops (Fig. 8/1) must be mounted in the stacking area on both ends of the tracks (Fig. 8/2).
- ☞ The exact positions are shown on the system drawing.

5. Insert end stops (Fig. 8/1) into the track (Fig. 8/2).

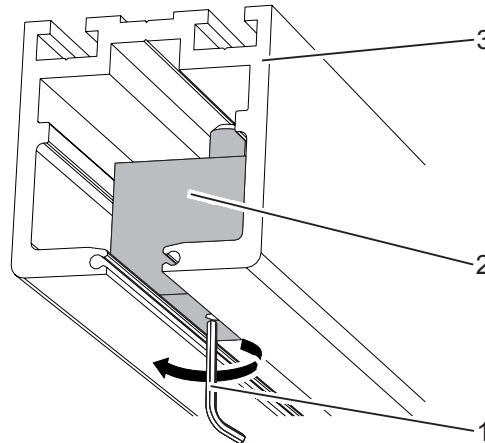

Fig. 9: Fastening the end stop

6. Fasten the end stop (Fig. 9/2) in the track (Fig. 9/3) using a socket head wrench (Fig. 9/1).
7. Mount the tracks to the ceiling (or the substructure) according to the system drawing. Ensure the correct position of the revision piece (for inserting the rollers into the tracks). Screw tracks in distances of 300 mm. Keep a distance of 100 mm in the stacking area.
 - ☞ Observe the specified bore distances!
 - ☞ Do not yet screw the revision piece as it will be removed again during the course of the assembly.

4.3 Mounting the wall mounting profiles

Wall mounting profiles may be installed with or without door hinges. If a single action door is part of the scope of delivery, the wall mounting profiles have to be provided with door hinges.

1. Align the wall mounting profile vertically and in the center below the track.

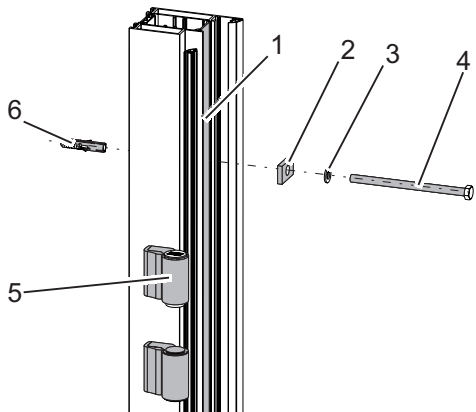

Fig. 10: Mounting the wall mounting profile

The boreholes for the wall mounting in single action doors must be drilled close to the door hinges (Fig. 10/5), if there are any.

Make sure that you do not drill at the height of the door hinges, if there are any.

2. Spread over the wall mounting profile, drill four centered boreholes through the plastic profile (Fig. 10/1) into the wall. Note the specifications of the manufacturer of the wall plugs.
3. Depending on the building fabric, use suitable wall plugs (Fig. 10/6) or similar.
4. Insert plates (Fig. 10/2).

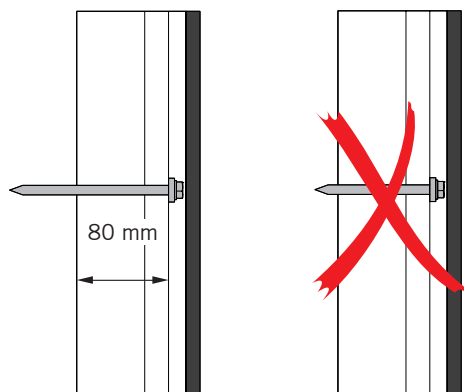

Fig. 11: Screw length

5. Fasten the wall mounting profiles using suitable screws (Fig. 10/4 and Fig. 11) and suitable washers (Fig. 10/3).
6. Now mount the wall mounting profile on the opposite side

4.4 Mounting the bottom rail

First mount a bottom rail to the floor if a fixed panel (FT) is installed.

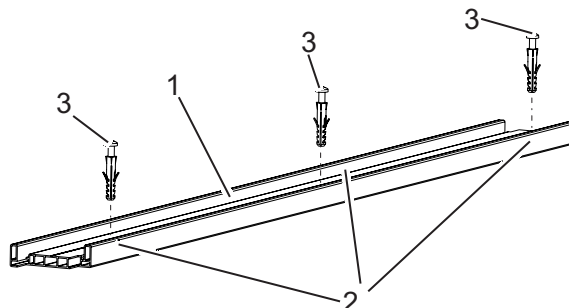

Fig. 12: Mounting the bottom rail

1. Align bottom rail (Fig. 12/1) according to the system drawing.
2. Mark the boreholes (Fig. 12/2) and drill the holes.
3. Fasten the bottom rail with screws and wall plugs (Fig. 12/3) suitable for the building fabric to the floor.

4.5 Mounting the fixed panel

If a fixed panel (Fig. 1/E) is part of the scope of delivery, it must be installed prior to the panels. The fixed panel (Fig. 1/E) features fixed panel holders instead of rollers.

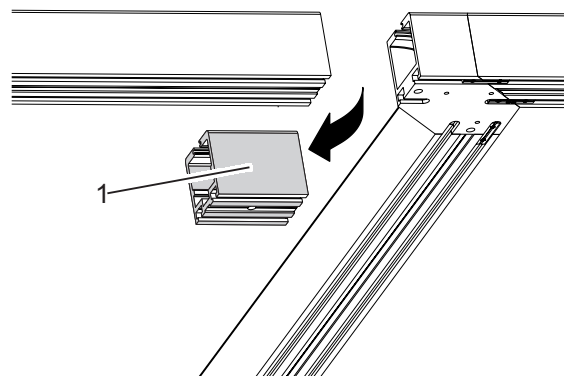

Fig. 13: Removing the revision piece

1. Remove the revision piece (Fig. 13/1).
2. Lift the fixed panel with two technicians.

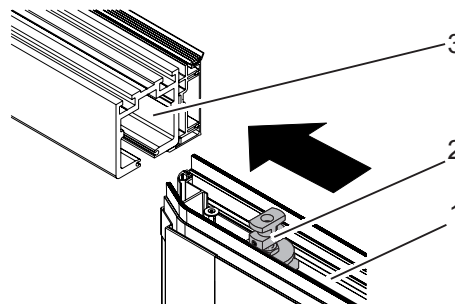

Fig. 14: Attaching the fixed panel to the track

3. Slide the fixed panel (Fig. 14/1) with the first fixed panel holder (Fig. 14/2) into the track (Fig. 14/3).

- Slide the side screen with the second fixed panel holder into the track.

► The fixed panel is now inside the tracks.

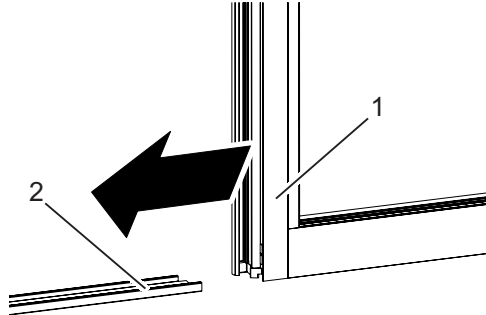

Fig. 15: Fixed panel

- Move the fixed panel (Fig. 15/1) into the intended position and slide it with the lower edge onto the bottom rail (Fig. 15/2).

☞ The fixed panel must be flush with the wall mounting profile.

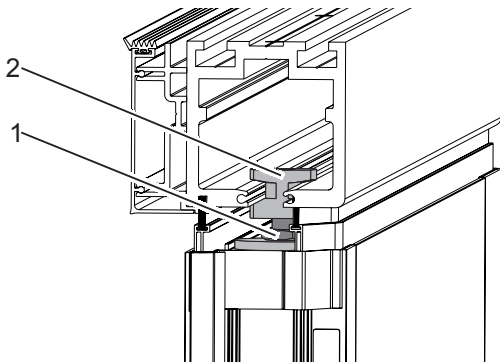

Fig. 16: Fastening the fixed panel holder

- Slightly turn the locking screws (Fig. 16/1) on the fixed panel holders (Fig. 16/2) until the fixed panel holder is fixed.

4.6 Mounting the single action door

- ☞ If a single action door (Fig. 1/A) is included in the scope of delivery, it must be the next item to be installed.
- ☞ For the assembly of the door hinges, follow the separate mounting instructions of the manufacturer.

- If not already done, remove the revision piece.
- Lift the single action door with two persons.

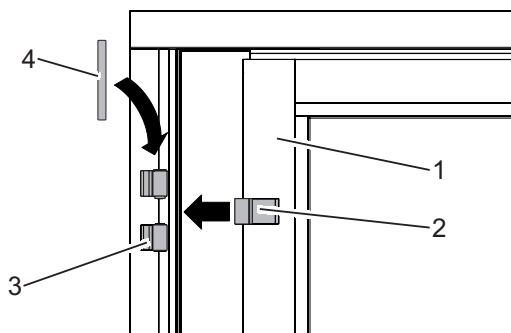

Fig. 17: Inserting the single action door into the door hinges

- Insert the single action door (Fig. 17/1) with the hinges (Fig. 17/2) into the door hinges (Fig. 17/3).

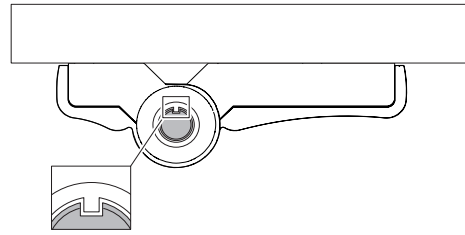

Fig. 18: Inserting door hinge pin

- Insert the door hinge pins (Fig. 17/4). Groove and lug must interlock (Fig. 18). If necessary, slightly turn the door hinge pin.

- Fasten the door hinge pin with the threaded pin.

► The single action door is now secured.

4.7 Mounting the panels

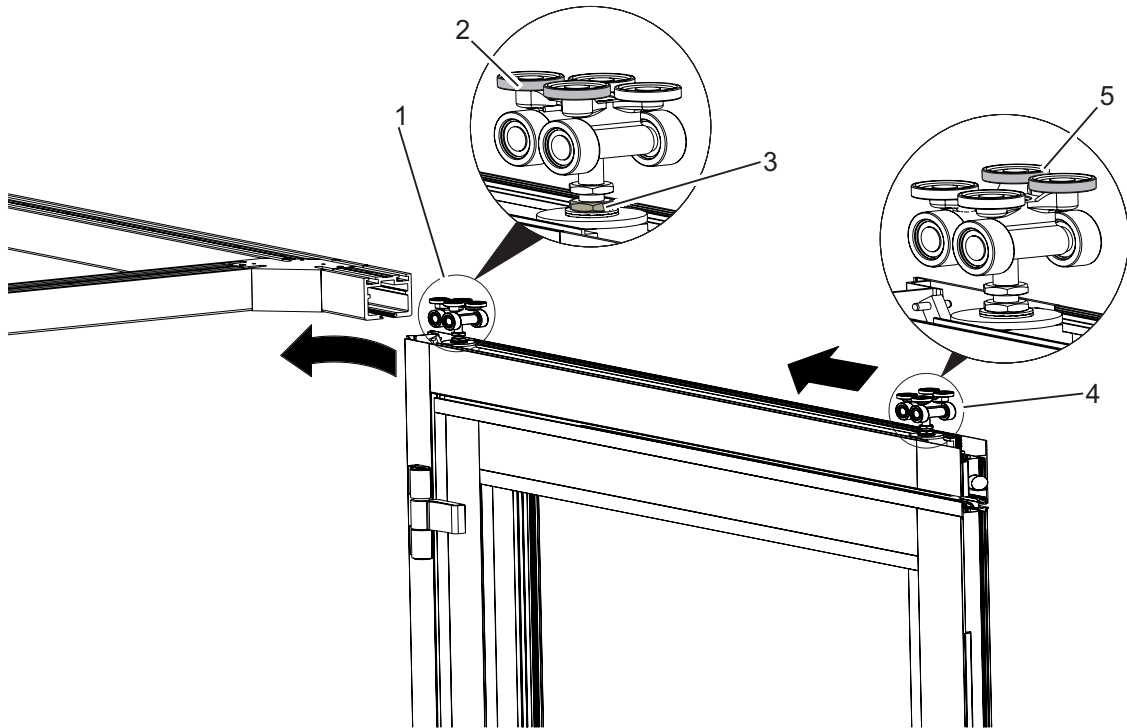

Fig. 19: Adjusting the running direction of the rollers.

Adjust the running direction of the rollers. Mount the panels and ensure the correct position of the rollers and the rollers. The position of the rollers is determined by the specified stacking arrangement in the stacking area. The position of the stacking area and the stacking arrangement of the panels is shown in the separately supplied system drawing.

1. If not done, remove the revision piece (Fig. 14/1).
2. Check the running direction of the rollers. If necessary, turn the rollers.
3. Mount the panel (Fig. 20/2) in the specified order (see separately supplied system drawing) with the roller into the tracks. Start with the panel that is parked first in the stacking area.
4. Mount all remaining panels.
 - ☞ Do not yet tighten the rollers as there has to be a fine adjustment.
5. Install the revision piece and fasten it with the connecting elements.

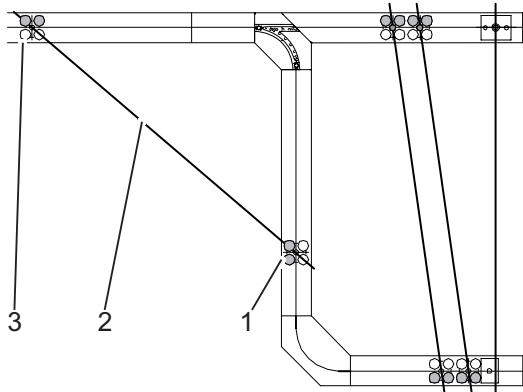

Fig. 20: Example for a stacking arrangement (top view)

The higher lying rollers define the running direction. In the exemplary Fig. 19 and Fig. 20, the front roller (Fig. 19/1 and Fig. 20/1) runs into the branch. The higher lying rollers (Fig. 19/2) are on the inner track side. In case of the rear roller (Fig. 19/4 and Fig. 20/3), the rollers (Fig. 19/5) are on the inner side of the track.

The roller runs straight in the stacking area.

4.8 Aligning the panels

4.8.1 Aligning the panels in a stacking arrangement

The panels must be aligned in the stacking area so that they cannot collide in the stacking arrangement and that the lateral distance is not too large.

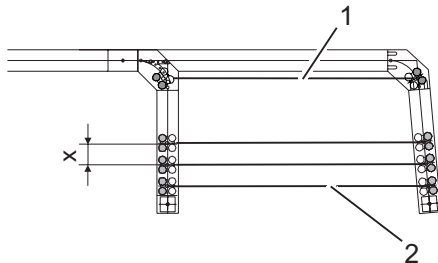

Fig. 21: Stacking arrangement in the stacking area (example)

- 1 Panels during the parking
- 2 Parked panel

Dimension x: 90 mm

The tracks in the stacking area are slightly running apart at an angle of approx. 95° so that the rollers of the panels will lock at a certain insertion width when the desired parking position has been achieved.

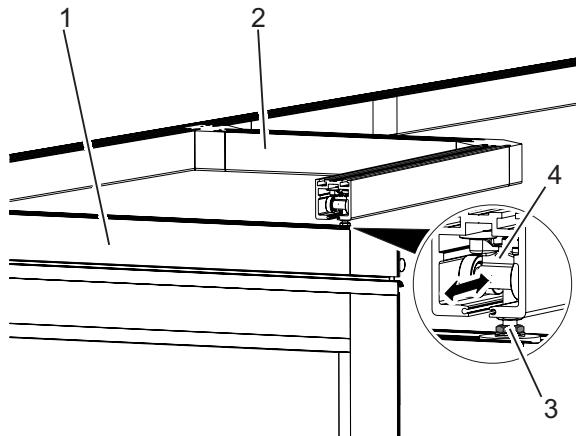

Fig. 22: Moving the rollers

1. Move the panel (Fig. 22/1), which is to be parked first in the stacking area (Fig. 22/2), into the stacking area.
2. Slightly loosen the nut (Fig. 22/3) at the branching off roller (Fig. 22/4).
3. Align the panel so that it is in the desired end position in the stacking area.
4. Tighten the nut (Fig. 22/3) on the roller.
5. Move the panel out of the stacking area and move it again into the intended end position. Check whether the panel will stop at the desired position.
6. If the panel still does not park as desired, move the roller again until the desired parking position has been reached.
7. Move the next panel into the stacking area and loosen the nut on the roller.
8. Depending on the door handle and/or lever, align the panel in the stacking area in such a way that the distance from the other panels is dimension x (Fig. 21). Observe the system drawing.

9. Tighten the nut.

10. Check whether the panel stops are at the correct distance (Fig. 21/dimension x) and parallel to the panel in front of it at the intended position in the stacking area. Otherwise, readjust the parking position.

11. Adjust all other panels as described in steps 7 to 10.

4.8.2 Height-alignment of the panels

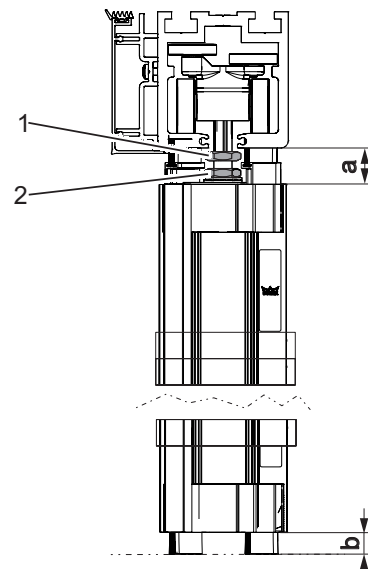

Fig. 23: Height-alignment of the panels

Dimension a: 20 ± 4 mm

Dimension b: 10 mm

☞ The height is measured without brush.

1. On both rollers, loosen the nut (Fig. 23/2) and adjust the screw at the hexagonal (Fig. 23/1) until the height distance to the floor is 10 mm (dimension b). Pay attention to the upper dimension a (20 ± 4 mm).
2. Proceed according to step 1 with all panels.

4.8.3 Lateral alignment of the panels

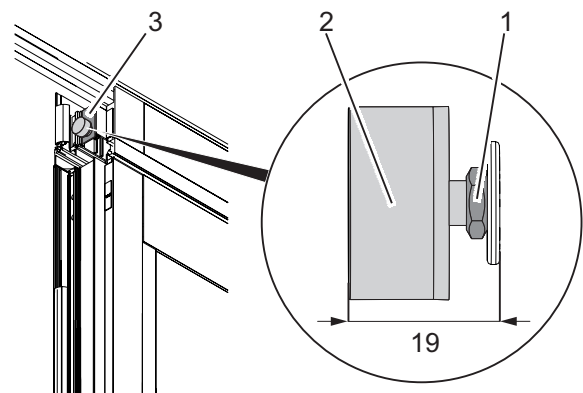

Fig. 24: Lateral alignment of the panels

The lateral distance of the panels is adjusted via rubber buffer (Fig. 24/2). The lateral distance between two panels (without brushes) at delivery is 5 ± 2 mm. In order to achieve this distance, there is a 19 mm distance between the upper edge of the rubber buffer (Fig. 24/2) and the plastic edge of the web (Fig. 24/3). If necessary, readjust the lateral distance.

1. Move the panel in order to reach the rubber buffer.
2. Adjust the rubber buffer via the nut (Fig. 24/1) until there is a distance of 19 mm between the upper edge and the plastic web (Fig. 24/3).

4.9 Mounting the lower locking device

All panels require a bushing in the floor for accepting the lower locking bolt.

Requirements:

- The panel is aligned along the height and the side.
1. Move the panel (Fig. 25/2) into the end position.
 2. Position the drilling template (Fig. 25/1) below the locking bolt (Fig. 25/3).

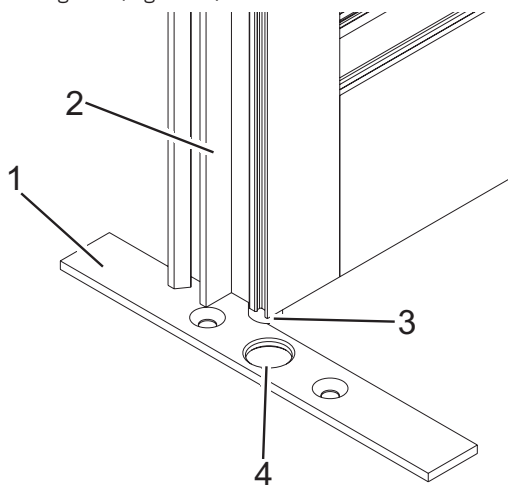

Fig. 25: Positioning the drilling template

3. Slowly operate the panel lock and center the locking bolt (Fig. 25/3) in the borehole (Fig. 25/4) of the drilling template.
4. Check the centered position of the drilling template by lowering the locking bolt several times.
5. Fasten the drilling template.
6. Unlock the panel and pivot it away.
7. Mark the planned borehole using the template.
8. Remove the drilling template.

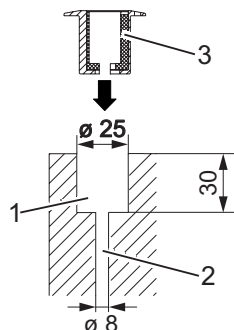

Fig. 26: Borehole for the eccentric bushing

9. Drill the hole (Fig. 26/1) with $\varnothing 25$ mm at least 30 mm deep.
10. Drill the hole (Fig. 26/2) with $\varnothing 8$ mm for the fastening of the eccentric bushing with wall plugs or similar.

11. Insert the eccentric bushing (Fig. 26/3) and screw it in place using suitable mounting material.
12. Move the panel into the end position and test the locking device.
13. If needed, turn the eccentric bushing with a screwdriver until you have the optimal position.

4.10 Adjusting the upper locking devices

4.10.1 Adjust the single action sliding panel locking device

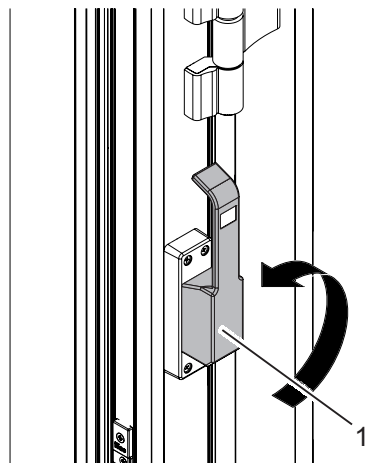

Fig. 27: Adjusting the sliding panel function

1. Slowly move the door lock bar (Fig. 27/1) upward into the sliding mode.

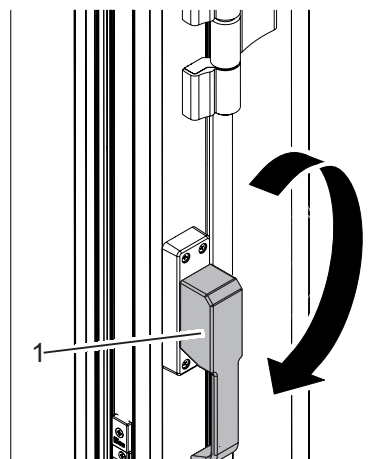

Fig. 28: Switching to the single action door mode

2. Move the door lock bar (Fig. 28/1) in the direction of the arrow into the lower end position.
 - ▶ The single action door mode is now activated.
 - ▶ Move the upper pressure plate and the lower locking bolt into their end position.
- ⚠ If a door cannot be easily opened after the adjustment, you must adjust the height of the pressure plate.

4.10.2 Adjusting the pressure plate

The mushroom head must align with the holding fixture in the track when the pressure plate is extended. If this is not the case, the height of the pressure plate must be adjusted.

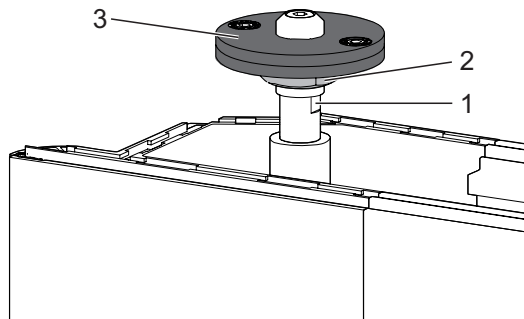

Fig. 29: Adjusting the pressure plate

1. Bring the panel into the parking position.
2. Turn the door lock bar slightly down so that the bolt can be accessed and is more visible.
3. Hold the bolt using a SW9 wrench (Fig. 29/1).
4. Loosen the nut (Fig. 29/2) using a SW18 wrench.

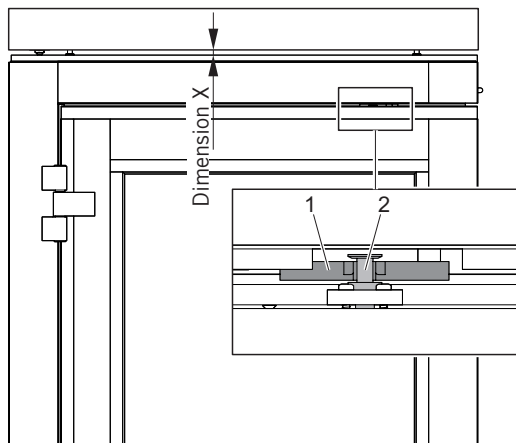

Fig. 30: Adjusting the holding fixture

5. Turn the pressure plate (Fig. 29/3) with your hands upward or downward.
 - ▶ Turn the pressure plate upward if the holding fixture (Fig. 30/1) for the mushroom head (Fig. 30/2) extends beyond the mushroom head or if the dimension $X > 20$ mm.
 - ▶ Turn the pressure plate downward if the holding fixture (Fig. 30/1) for the mushroom head (Fig. 30/2) is located before the recess in the profile or if the dimension $X < 20$ mm.
 - ▶ The distance between the track and the support profile is 20 mm.
6. Retighten the nut (Fig. 29/2) using a SW18 wrench.
 - ▶ The pressure plate is now adjusted and the mushroom head sinks into the pressure plate.
7. Move the single action sliding panel into position and check whether the mushroom head and the holding fixture align with a full rotation of the door lock bar. If necessary, repeat the adjustment.

4.10.3 Lengthwise adjustment of the bolt carrying plate

If the mushroom head does not properly align with the groove of the holding fixture, you must move the bolt carrying plate.

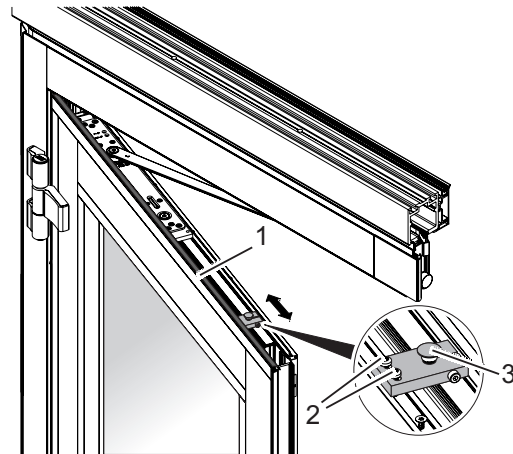

Fig. 31: Moving the bolt carrying plate

1. Remove the rubber seal (Fig. 31/1).
2. Loosen the screws (Fig. 31/2).
3. Move the bolt carrying plate (Fig. 31/3) until the mushroom head reaches into the holding fixture.
4. Tighten the screws (Fig. 31/2).
5. Install the rubber seal.
6. Close the door.
7. Move the door lock bar upward into the sliding mode. Check whether the door locks.
8. Now turn the door lock bar downward again. Check whether the mushroom head now aligns with the holding fixture.

4.11 Inserting glass panels

- ☞ The glazing can only be roughly described. For detailed instructions, please refer to the glazing regulations of the suppliers.
- ☞ Install only intact glass panels (without chonchoidal fractures or damaged edges).

Requirement:

- The panel is aligned.

Required material:

- Glass panels
- Block levers
- Spacer blocks
- Glass clamping profiles
- Seals

4.11.1 Positioning of the glazing blocks

☞ The position of the glazing blocks depends on the type of panel. There are carrying blocks and spacer blocks. The carrying blocks are used to jam and align the glass panel. The spacer blocks keep the distance to the profile.

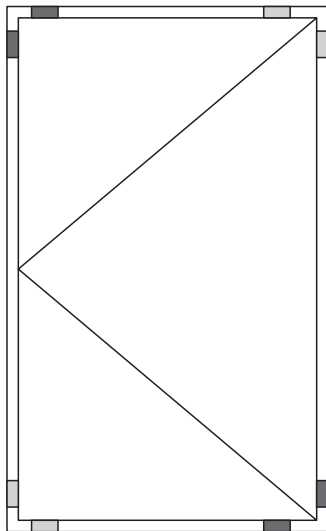
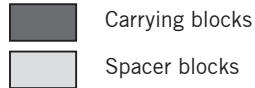

Fig. 32: Single action sliding panel and pivoting end panel

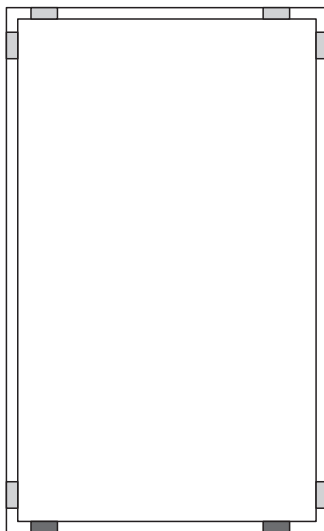

Fig. 33: Sliding panel and fixed panel

☞ In case of the single action sliding panel, pay special attention to the positioning of the carrying blocks (Fig. 32). The functions of the panels may otherwise be affected and not even be available.

4.11.2 Glazing the panels

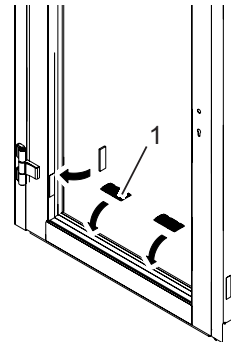

Fig. 34: Inserting the glazing blocks

1. Insert two glazing blocks (Fig. 34/1) on each side.

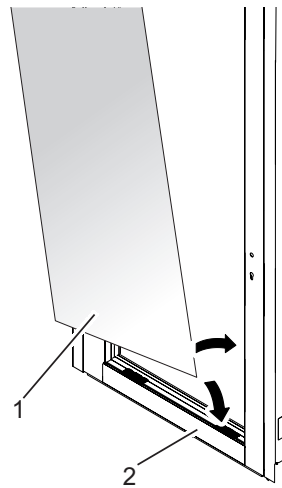

Fig. 35: Inserting the glass panel



WARNING!

Risk of injury due to breaking or overturning glass panels!

- Note the own weight of the glass weight.
- Wear non-slip protective gloves.
- Lift glass panels only with two persons.
- Use a glass lifter.

2. Insert glass panel (Fig. 35/1) into panel (Fig. 35/2).

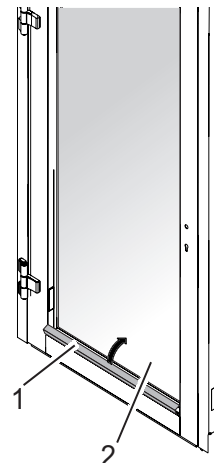

Fig. 36: Putting the glass clamping profile into place

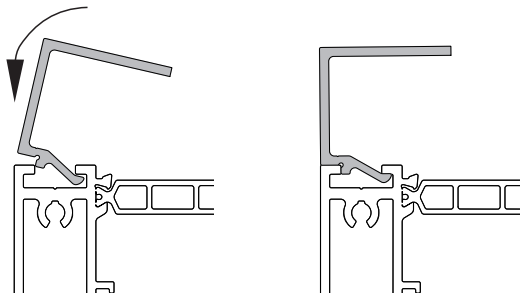

Fig. 37: Mounting the glass clamping profile

3. Insert the glass clamping profile (Fig. 37) into the profile in an inclined way and press down at the leading edge.



Fig. 38: Inserting the seal

4. Place the seal (Fig. 38/1) between glass panel (Fig. 38/2) and glass clamping profile (Fig. 38/3) and press from the inside to the outside.

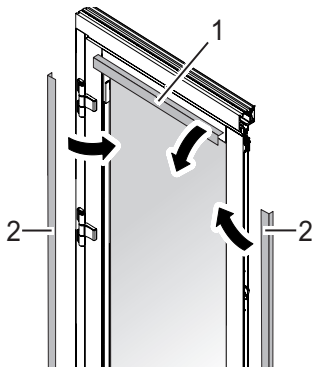

Fig. 39: Inserting the glass clamping profiles

5. Insert the glass clamping profile on the opposite front side (Fig. 39/1) into the profile in an inclined way and press down at the leading edge (Fig. 37).
6. Insert the seal (see step 4).
7. Insert the glass clamping profiles and seal at the long sides (Fig. 39/2).
8. Install the glass panels in all other panels and doors in the same way.

4.12 Mounting the door handles

Door handles and closing mechanism are to be installed according to the system drawing. For detailed instructions, please refer to the mounting instructions of the manufacturers.

4.13 Adjusting the locking plates

4.13.1 Adjusting the auxiliary lock

The auxiliary lock can be adjusted to ensure the correct closing function.

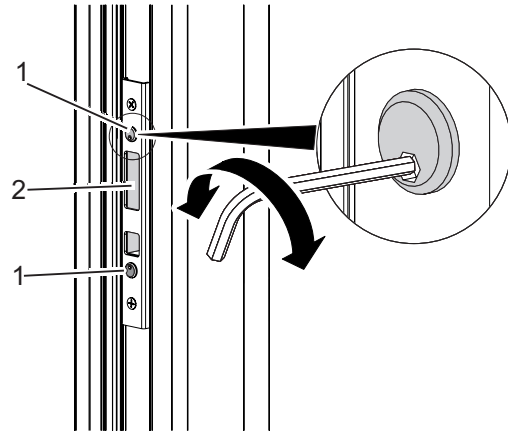

Fig. 40: Adjusting the auxiliary lock

1. Turn the adjusting screws (Fig. 40/1) using a hexagon wrench.
 - The inner insert (Fig. 40/2) will be slightly moved into the desired direction.
2. Check the closing operation of the door. If necessary, repeat the adjustments.

4.13.2 Adjusting the center locking plate

You can slightly move the center locking plate in its position if the closing of the door is faulty.

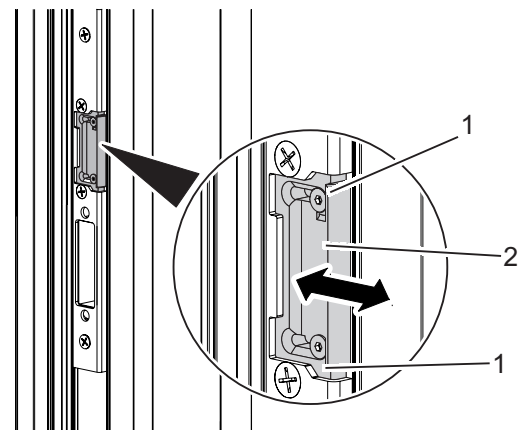

Fig. 41: Adjusting the center locking plate

1. Slightly loose the screws (Fig. 41/1).
2. Move the center locking plate (Fig. 41/2) into the desired direction.
3. Check the closing operation of the door. If necessary, repeat the adjustments.

4.14 Mounting the track cover

☞ You can optionally mount a track cover to the tracks in order to prevent thermal bridges. The position of the track cover is shown on the system drawing.

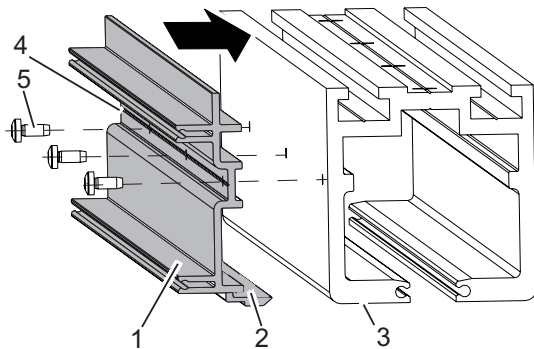

Fig. 42: Mounting the track cover

1. Place the plastic element (Fig. 42/1) to the track so that the surface (Fig. 42/2) rests on the lower edge (Fig. 10/3) of the track.
2. Place the drill inside the plastic groove (Fig. 42/4) and drill holes with \varnothing 4.6 mm through the track at a distance of 400 mm.
 - ☞ Do not drill the revision piece.
3. Thoroughly clean the track on the inside to remove chips and dirt.
4. Fasten the plastic element with the enclosed self-threading M5 screws (Fig. 42/5). Tighten with TX25.

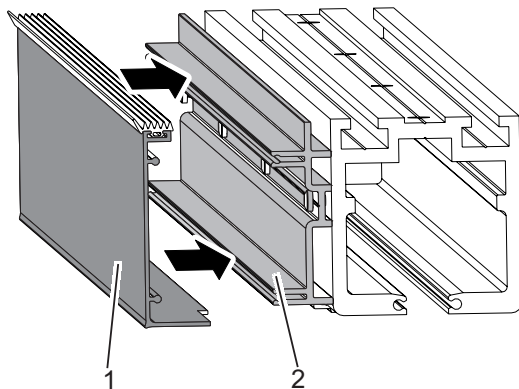

Fig. 43: Attaching the cover

5. Attach the cover (Fig. 43/1) to the plastic element (Fig. 43/2).

4.15 Adjusting the brush seals

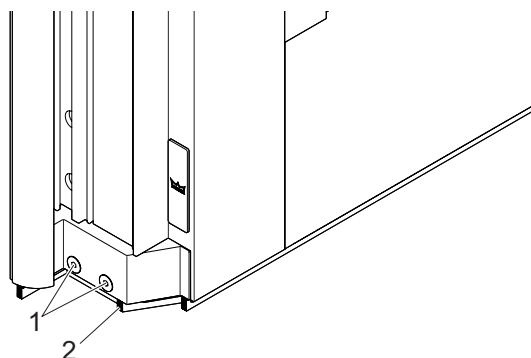

Fig. 44: Adjusting the brush

1. Loosen the screws (Fig. 43/1).
2. Push or pull the brushes (Fig. 43/1) for the adjustment.
3. Retighten the screws (Fig. 43/1).

4.16 Final inspection

1. Move all panels from the end position into the stacking area. It must be possible to move the panels easily and with one hand.
2. Check whether the panels can be properly locked and whether the locking bolts can easily slide into the bushes.

4.17 Replacing the brush seals

- ☞ Check the brush seals once a year.

4.17.1 Replacing the brush seals of the sliding panels and single action sliding panels

- ☞ Carry out the work with at least 2 technicians.

1. Park all panels in the stacking area.
2. Remove the revision piece.
3. Move the panels with the two rollers from the stacking area individually through the resultant gap.
 - ☞ Make sure that the panels rest only on the frame.

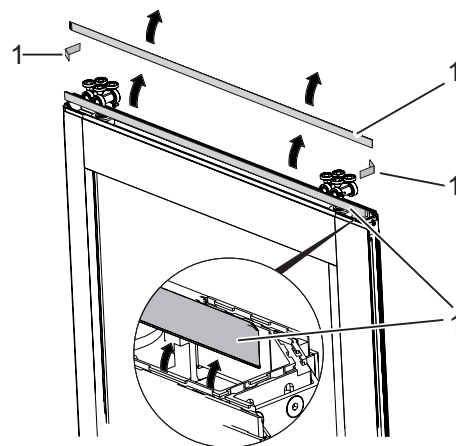

Fig. 45: Brush seals on the front sides

4. Place the panel horizontally on a secure base.
 - ☞ Brush seals (Fig. 40/1) are pulled into the profiles on the front sides.
5. Pull out old brush seals at the upper and the lower front side.
6. Insert the new brush seals at the upper and the lower front side. If necessary, glue the bottom side of the brushes to the profile. Pretreat the adhesive surfaces with primer and then glue it using cyanocrylate adhesive (instant glue).
7. Proceed according to steps 3 to 6 with all panels remaining the stacking area.
 - ☞ Keep the order of the panels during the installations.
8. Guide all panels starting with the panels removed most recently into the stacking area (Chapter „4.7 Mounting the panels“, p. 10).
9. Mount the revision piece.
10. Check the alignment of the panels (Chapter „4.8 Aligning the panels“, p. 11).
 - The brush seals of the sliding panels and single action sliding panels are now replaced.

4.17.2 Replacing the brush seals of the single action door

☞ Carry out the work with at least 2 technicians.

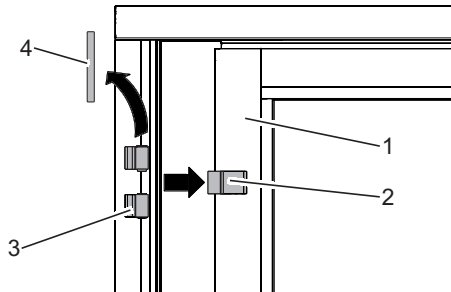

Fig. 46: Removing the single action door

1. Loosen the threaded pins and hinge pins (Fig. 41/4).
2. Lift the hinges (Fig. 41/2) of the single action door (Fig. 41/1) from the door hinges (Fig. 41/3) of the wall mounting profile.
 - ☞ Make sure that the single action door rests only on the frame.
3. Place the single action door horizontally on a secure base.
 - ☞ Brush seals (Fig. 40/1) are inserted at the front sides into the profiles.
4. Pull out old brush seals at the upper and the lower front side.
5. Insert the new brush seals at the upper and the lower front side. If necessary, glue the bottom side of the brushes to the profile. Pretreat the adhesive surfaces with primer and then glue it using cyanocrylate adhesive (instant glue).
6. Mount the single action door (Chapter „4.6 Mounting the single action door“, p. 9).
 - ▶ The brush seals at the single action door are now replaced.

4.17.3 Replacing the brush seals of the fixed panels

☞ Carry out the work with at least 2 technicians.

1. Remove the revision piece.

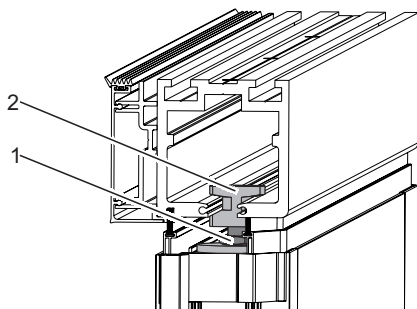

Fig. 47: Loosening the screws on the mount.

- ☞ Slightly turn the locking screws (Fig. 42/1) at the mounts using spanners (Fig. 42/2) so that the fixed panel can be more easily removed from the track.

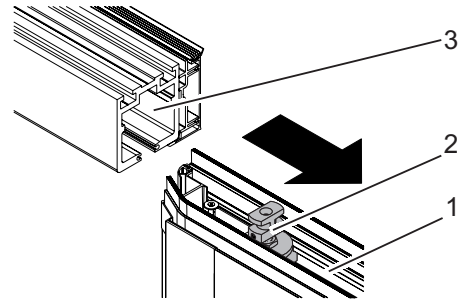

Fig. 48: Removing the fixed panel

2. Lift the fixed panel (Fig. 43/1) with the fixed panel holders (Fig. 43/2) evenly from the track at the resultant gap (Fig. 43/3) and the bottom rail.
 - ☞ Make sure that the fixed panel rests only on the frame.
3. Place the fixed panel horizontally on a secure base.
 - ☞ Brush seals (Fig. 40/1) are inserted at the upper front side.
 - ☞ Brush seals on fixed panels are mounted only to the upper front side because fixed panels with the lower front screen are inserted into the bottom rail.
4. Pull out old brush seals at the upper front side.
5. Insert the new brush seals at the upper front side.
6. Mount the fixed panel (Chapter „4.5 Mounting the fixed panel“, p. 8).
 - ▶ The brush seals at the fixed panel are now replaced.

5 Maintenance

Interval	Activity	Personnel
As required	Clean glass surfaces using a glass cleaner.	Operating personnel
	Clean metal parts of the HSW FLEX Therm.	Operating personnel
	<ul style="list-style-type: none"> ☞ Painted metal parts of the HSW FLEX Therm can be cleaned with glass cleaner together with the glass panels. 	
	Keep the deviation piece for the rollers of the rollers in the tracks free of grease and clean using acetone. <ul style="list-style-type: none"> ☞ Do not clean painted metal parts of the panels or tracks with acetone as the paint will be damaged by the acetone. ☞ Deviation pieces and rollers are made from plastic polyoxymethylene (POM) and are resistant against acetone. 	Operating personnel
Annually	Keep the bushings that accept the locking bolts clean.	Operating personnel
	Check door hinges and door handles.	Maintenance personnel
	Grease the locking devices.	Maintenance personnel
	Check locks and locking devices for free movement.	Maintenance personnel
	Check brush seal and, if necessary, replace them.	
	Replace the brush seals if the visual inspection shows that the installed brush seals are frayed or if a light gap occurs.	Maintenance personnel

6 Troubleshooting

Fault description	Cause	Remedy
The panels stick in the tracks.	The height adjustment of the panels is not correct.	Check the height alignment of the panels (Chapter „4.8.2 Height-alignment of the panels“, p. 11).
	The tracks are dirty.	Clean the tracks.
The panels cannot be correctly moved into the parking position.	The adjustment of the rollers is not correct.	Properly adjust the rollers (Chapter „4.8.1 Aligning the panels in a stacking arrangement“, p. 11).
The door of the single action sliding panel or the single action door cannot be properly closed.	The door lock is not properly adjusted.	Check the door lock adjustment (Chapter „4.13 Adjusting the locking plates“, p. 15).
	The height adjustment of the panels differs.	Adjust the rollers or block the glasses again (frame is no longer angled).
The door lock bar does not close properly.	The locking adjustment for the door dead-bolt is not properly adjusted.	Check the locking adjustment of the door lock bar (Chapter „4.10.1 Adjust the single action sliding panel locking device“, p. 12).
	The height of the pressure plate is not properly adjusted.	Carry out the length adjustment (Chapter „4.10.1 Adjust the single action sliding panel locking device“, p. 12).



dormakaba Deutschland GmbH
DORMA Platz 1
58256 ENNEPETAL
GERMANY
Tel. +49 2333 793-0
Fax +49 2333 793-4950
www.dormakaba.com

DORMA-Glas GmbH
Max-Planck-Straße 33-45
32107 BAD SALZUFLEN
GERMANY
Tel. +49 2333 793-0
Fax +49 2333 793-4950
www.dormakaba.com