

ED100/ED250

Sensors

Installation and Wiring Instructions

DL4614-130 – 08-2018

| EN |

Table of contents

Table of contents	2		
1 General information	3		
A Sensor installation and wiring	4		
A1.1 BEA LZR Microscan-T door mounted presence sensors, single door	4	A5.1 Optex Elite T swing door mounted sensor - single door	24
A1.2 BEA LZR Microscan-T door mounted presence sensors, double door	6	A5.2 Optex Elite T swing door mounted sensor - double doors	26
A2.1 BEA Superscan-T door mounted presence sensors, low energy application	8	A6.1 Optex Premier T header mount presence sensor, single door, low energy application	28
A3.1 BEA Bodyguard-T overhead presence sensor, single door swing side, low energy application	10	A6.2 Optex Premier T header mount presence sensor, door pair with Optex OA-EDGE-T door mounted swing side presence sensors	30
A3.2 BEA Bodyguard-T overhead presence sensor, double door swing side, low energy application	12	A7.1 Optex OA-Edge T door mounted presence sensors, swing and approach sides, one-way traffic	32
A3.3 BEA Bodyguard-T overhead presence sensor with Superscan-T door mounted swing side presence sensor, single door	14	A7.2 Optex OA-Edge T door mounted presence sensor, single door, swing side, low energy application	34
A3.4 BEA Bodyguard-T overhead presence sensor with Superscan-T door mounted presence and approach sensors, single door	16	A7.3 Optex OA-Edge T door mounted presence sensor, single door, approach side, low energy application	36
A3.5 BEA Bodyguard-T overhead presence sensor with Superscan-T door mounted swing and approach side presence sensors, pair	18	A8.1 Optex OA-FLEX T header mount presence sensor, single door, swing side, low energy application	38
A3.6 BEA Bodyguard-T overhead presence sensor with Superscan-T door mounted swing side presence sensors, pair	20		
A4.1 BEA Eagle activation sensor	22		

1 General information

1.1 Installation Instructions

This manual provides installation and wiring instructions for sensors used with ED100/ED250 automatic swing door operators.

1.2 Manual storage

This document must be kept in a secure place, and accessible for reference as required.
If the door system should be transferred to another facility, insure that this document is transferred as well.

1.3 dormakaba.com website

Manuals are available for review, download, and printing on the dormakaba.com website.

1.4 Symbols used in these instructions



WARNING

This symbol warns of hazards which could result in personal injury or threat to health.

NOTICE

Draws attention to important information presented in this document.

CAUTION

This symbol warns of a potentially unsafe procedure or situation.



TIPS AND RECOMMENDATIONS

Clarifies instructions or other information presented in this document.

1.5 Dimensions

Unless otherwise specified, all dimensions are given in inches (").

1.6 Sensors

1. BEA LZR Microscan-T door mounted presence
2. BEA Superscan-T door mounted presence
3. BEA Bodyguard-T overhead mounted presence
4. BEA Eagle overhead activation
5. Optex Elite T door mounted presence
6. Optex Premier T header mounted presence
7. Optex OA-Edge T door mounted presence
8. Optex OA-Flex T header or overhead mounted presence

A Sensor installation and wiring

A1.1 BEA LZR Microscan-T door mounted presence sensors, single door

Fig. A1.1.1 BEA LZR sensor wiring diagram, single door

- 1 ED100/ED250 terminal board
- 2 LZR Hub
- 2.1 Hub power port
- 2.2 Power supply harness
- 2.3 Hub Door Control A port
- 2.4 Door control A harness
- 2.5 Hub system port
- 2.6 System harness
- 2.7 On/Off/Hold port
- 2.7.1 On/Off/Hold port jumper (supplied)
- 2.9 Sensor inputs
- 2.11 Adjustment knob
- 2.12 LCD
- 2.13 Hub LEDs

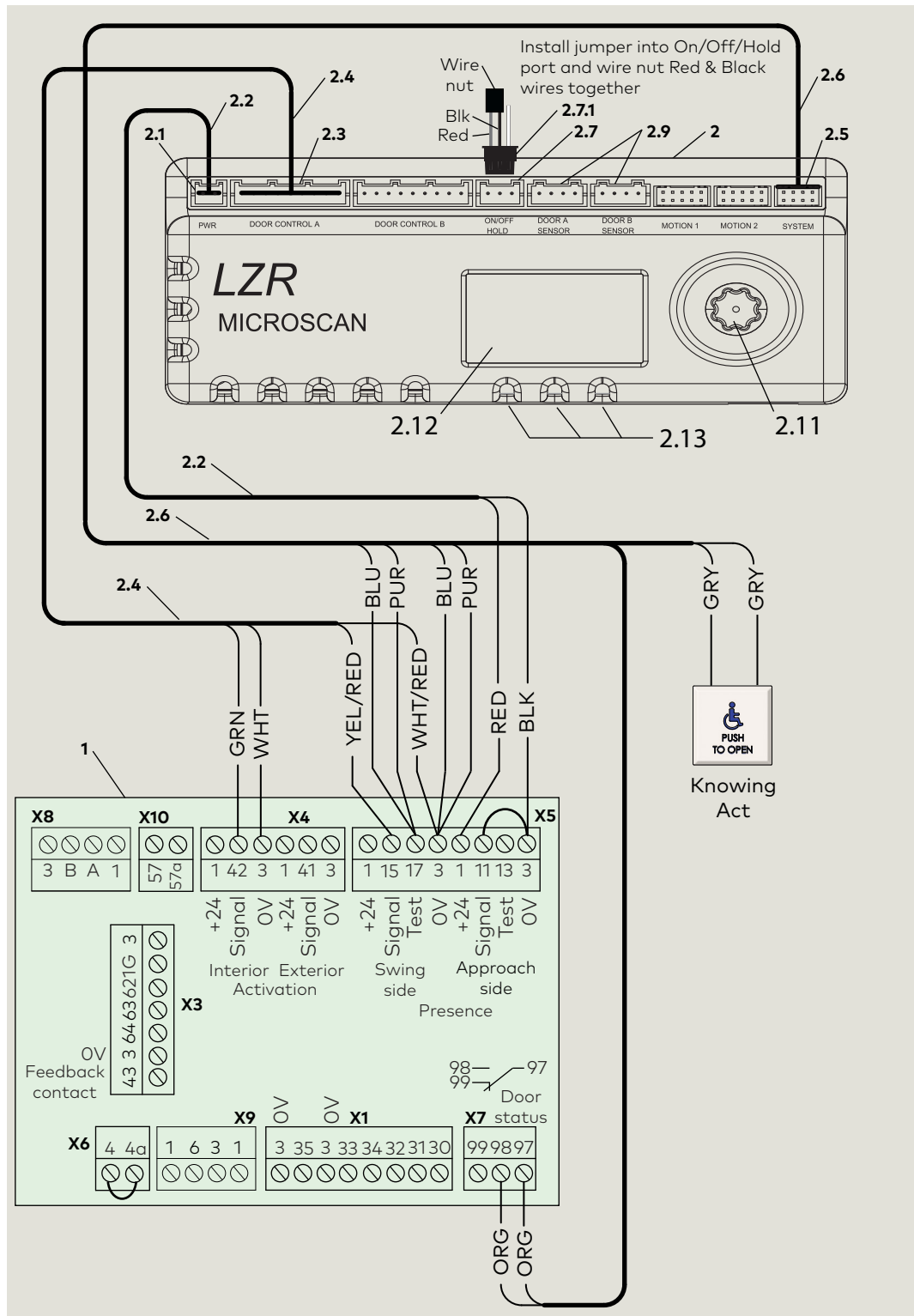

NOTICE

Activation sensor required.
Reference Para. 4.1, BEA Eagle.

CAUTION

Refer to BEA LZR Microscan T user guide for sensor installation, wiring, programming and setup.
On/Off/Hold port jumper must be installed and a wire nut installed between Red & Blk wires.

A1.1.1 Power supply harness (2.2)

LZR		ED100/ED250	
RED	Power	X5-1	+24 V
BLK	0 V	X5-3	0 V

A1.1.2 Door Control A harness (2.4)

LZR		ED100/ED250	
GRN	Activation, N.O.	X4-42	Interior activation signal
WHT	Activation, COM	X4-3	0 V
YEL/ RED	Stall, N.C.	X5-15	Swing side safety sensor signal
WHT/ RED	Stall, COM	X5-3	0 V

A1.1.3 System harness (2.6)

LZR		ED100/ED250	
PUR	Monitoring	X5-17	Swing side test
PUR	Monitoring	X5-3	0 V+
ORG	Home switch	X7-98	Door status, N.O.
ORG	Home switch	X7-97	Door status, COM
GRY	Knowing act		
GRY	Knowing act		
BLU	Monitoring	X5-17	Parallel with PUR
BLU	Monitoring	X5-3	Parallel with PUR

Fig. A1.1.2 One way traffic

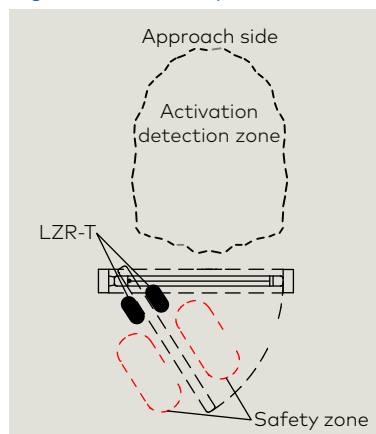

NOTICE

Activation sensor required.
Reference Para. 4.1, BEA Eagle.

A1.1.4 Install and commission BEA LZR Microscan T sensors.

CAUTION

ED100/ED250 operator must have full learning cycle completed prior to sensor installation.

NOTICE

Confirm controller firmware is v2.1 or higher during learn cycle.

1. Set ED100/ED250 parameters for sensor setup.

ST Safety Sensor Test	0	Test off, safety sensors not tested. (factory default.)
---------------------------------	----------	---

2. Program LZR Hub menu 1 and menu 2 per LZR Microscan T setup instructions. Required LZR settings for ED100/ED250 controller:

LZR Menu 1 (Basic)		LZR Menu 2 (Advanced)	
Door type	Single	Monitoring	OFF
		Monitor Logic	Active Low

3. Perform learn per LZR Microscan T setup instructions.
4. Set final LZR hub settings required for ED100/ED250 controller.

LZR Menu 2 (Advanced)	
Monitoring	Stall
Monitor Logic	Active low

5. Set final ED100/ED250 parameter values.

ST Safety Sensor Test	4	Sensor test on swing side, active low level.
---------------------------------	----------	--

SA Activation by safety sensor on approach (opposite hinge) side	1	Safety sensor can trigger an opening pulse while door is closed.
--	----------	--

TIPS AND RECOMMENDATIONS

Door status relay **X7, 97, 98, 99**.
Sr status relay function parameter = **1** (factory setting).
Status relay activated as soon as door reaches "closed" position.

A1.2 BEA LZR Microscan-T door mounted presence sensors, double door

Fig. A 1.2.1 BEA LZR sensor wiring diagram, double door

- 1 ED100/ED250 terminal board, active door
- 2 LZR Hub
- 2.1 Hub power port
- 2.2 Power supply harness
- 2.3 Hub Door Control A port
- 2.4 Active door control harness
- 2.5 Hub system port
- 2.6 System harness
- 2.7 On/Off/Hold port
- 2.7.1 On/Off hold port jumper (supplied)
- 2.9 Hub Door Control B port
- 2.10 Inactive door control harness
- 2.11 Adjustment knob
- 2.12 LCD
- 2.13 Hub LEDs
- 3 ED100/ED250 terminal board, inactive door

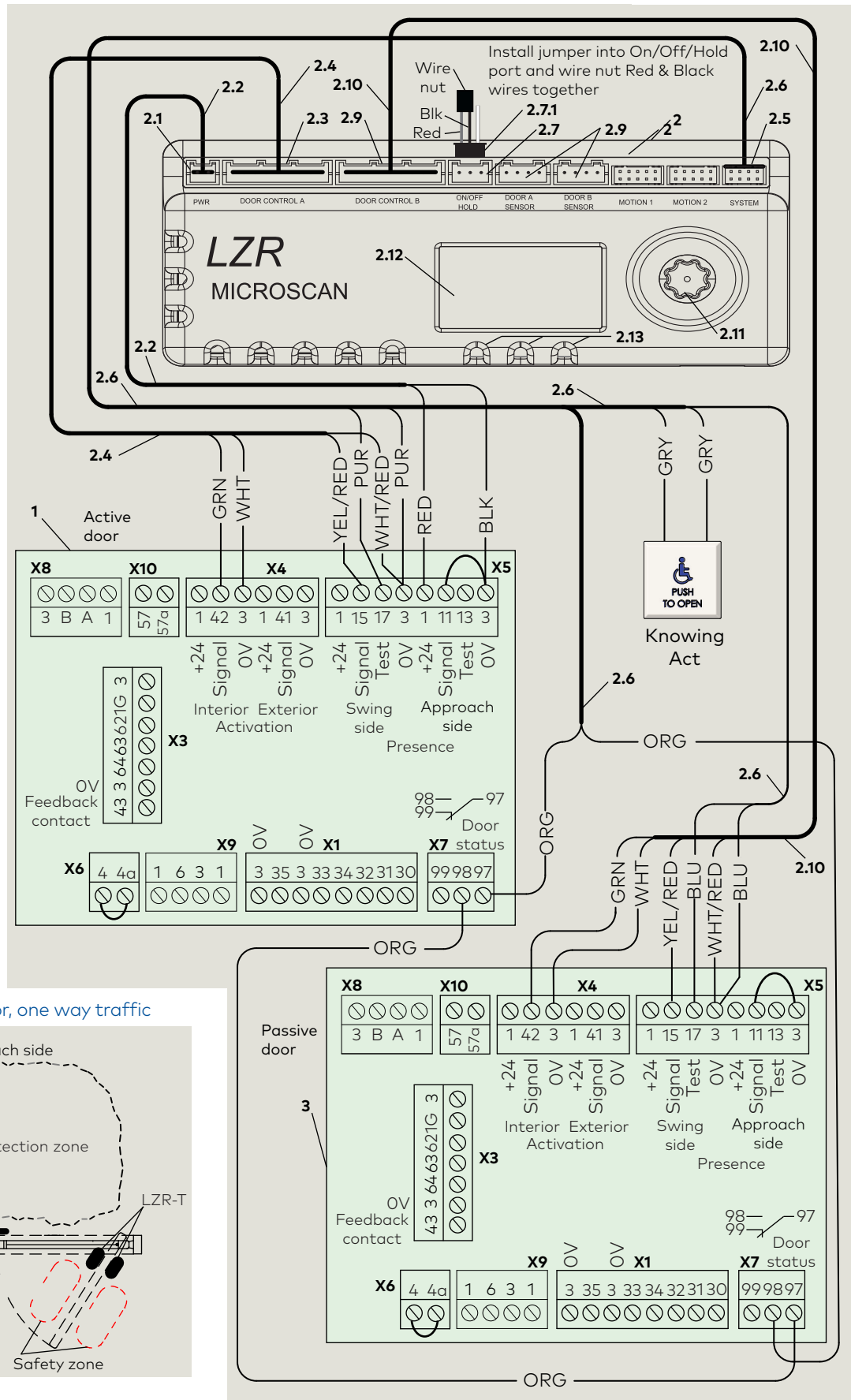

NOTICE

Activation sensor required.
Reference Para. 4.1, BEA Eagle.

Fig. A 1.2.2 Double door, one way traffic

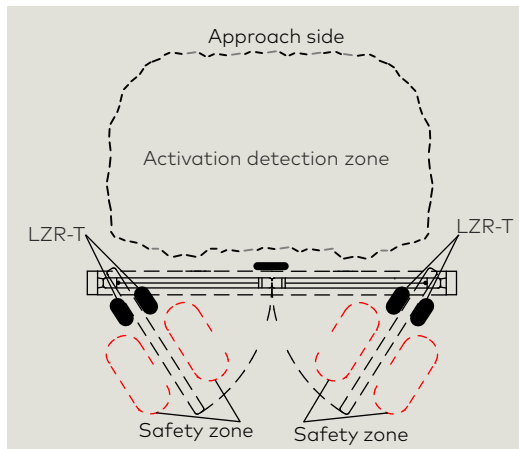

Sensor Installation and Wiring Instructions

CAUTION

Refer to BEA LZR Microscan T user guide for sensor installation, wiring, programming and setup.
On/Off/Hold port jumper must be installed and a wire nut installed between Red & Blk wires.

A1.2.1 Power supply harness (2.2)

LZR		ED100/ED250	
RED	Power	X5-1	+24 V
BLK	0 V	X5-3	0 V

A1.2.2 Door Control A harness (2.4)

LZR		ED100/ED250 active door	
GRN	Activation, N.O.	X4-42	Interior activation sensor
WHT	Activation, COM	X4-3	0 V
YEL/RED	Stall, N.C.	X5-15	Swing side safety sensor signal
WHT/RED	Stall, COM	X5-3	0 V

A1.2.3 Door Control B harness (2.10)

LZR		ED100/ED250 inactive door	
GRN	Activation, N.O.	X4-42	Interior activation sensor input
WHT	Activation, COM	X4-3	0 V
YEL/RED	Home switch	X5-15	Stall N.C., inactive door
WHT/RED	Home switch	X5-3	Stall N.C., active door

A1.2.4 System harness (2.6)

LZR		ED100/ED250	
PUR	Monitoring, active door	X5-17	Safety sensor output test
PUR	Monitoring, active door	X5-3	0 V
ORG	Stall, N.C., inactive door	X7-98	Door status, N.O*
ORG	Stall, COM, active door	X7-97	Door status, COM*
GRY	Knowing act		
GRY	Knowing act		
BLU	Monitoring, inactive door	X5-17	Safety sensor output test, swing side
BLU	Monitoring, inactive door	X5-3	0 V

*Connect orange wire from active door X7-98 to inactive door X7-97.

A1.2.5 Install and commission BEA LZR Microscan T sensors.

CAUTION

Both ED100/ED250 operators must have full learning cycle completed prior to sensor installation.

CAUTION

Parameter **dL** must be set to "0" on both ED100/ED250 operators for single door commissioning.

NOTICE

Confirm controller firmware is v2.1 or higher during learn cycle.

1. Set ED100/ED250 parameters for sensor setup.

DL Door type	0	Single
ST Safety Sensor Test	0	Test off, safety sensors not tested. (factory s)

2. Program LZR Hub menu 1 and menu 2 per LZR Microscan T setup instructions. Required settings for ED100/ED250 controller:

LZR Menu 1 (Basic)	LZR Menu 2 (Advanced)		
Door type	Pair	Monitoring	OFF
		Monitor Logic	Active Low

3. Perform learn per LZR Microscan T setup instructions.
4. Set final LZR hub settings required for controller.

LZR Menu 2 (Advanced)	
Monitoring	Stall
Monitor Logic	Active low

5. Set final ED100/ED250 parameter values.

DL Door type	0	Single (factory default)
ST Safety Sensor Test	4	Sensor test on swing side, active low level.
SA Activation by safety sensor on approach (opposite hinge) side	1	Safety sensor can trigger an opening pulse while door is closed.



TIPS AND RECOMMENDATIONS

Door status relay **X7, 97, 98, 99**.
Sr status relay function parameter = **1** (factory setting).
Status relay activated as soon as door reaches "closed" position.

A2.1 BEA Superscan-T door mounted presence sensors, low energy application

FIG. A2.1.1 BEA Superscan-T wiring

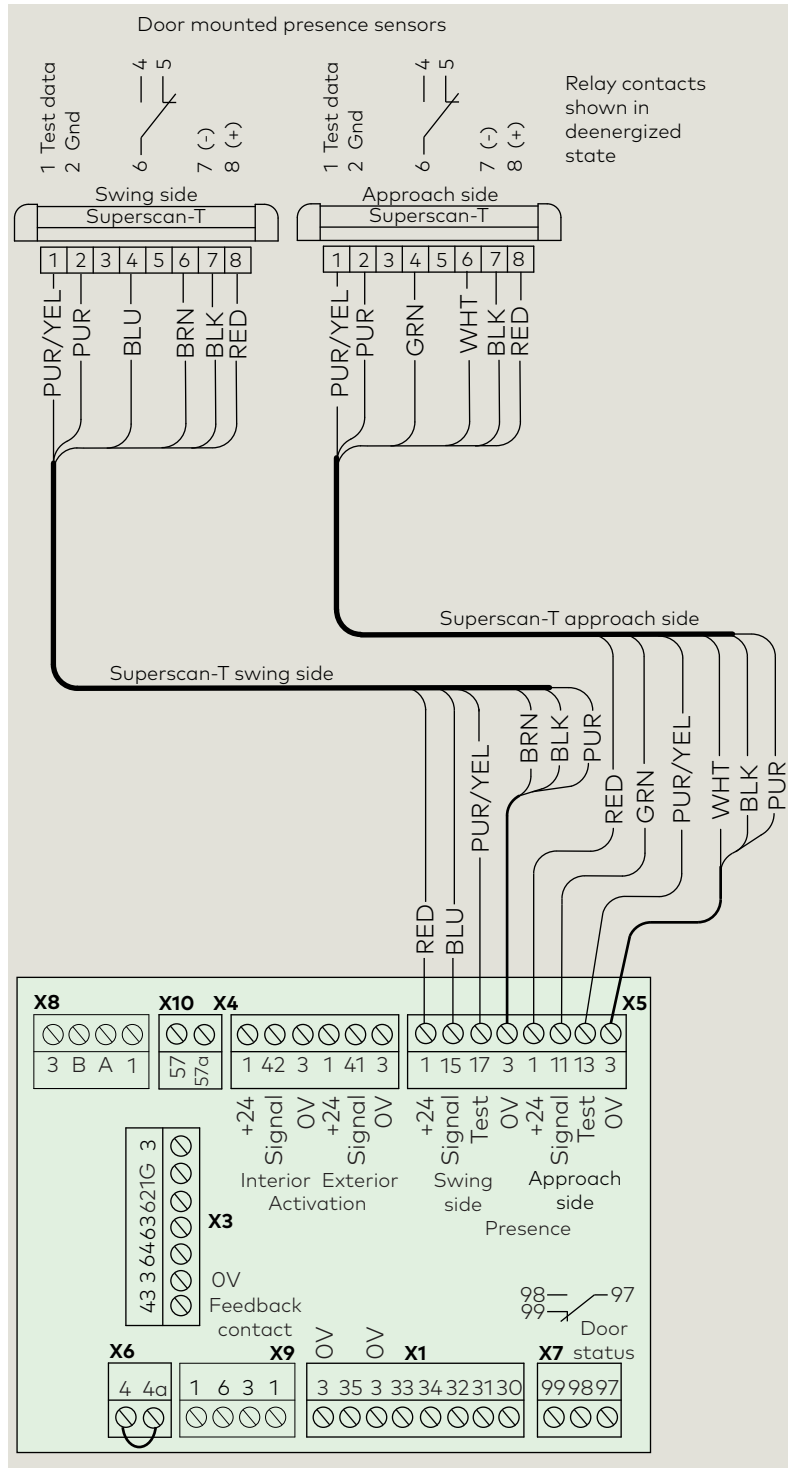
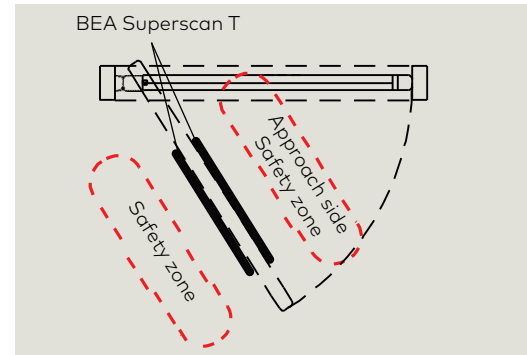

Fig. A2.1.2 BEA Superscan-T safety zones



CAUTION

BEA Superscan T does not comply with requirements of ANSI/BHMA 156.10, Para. 8.2.2.2, as a stand-alone presence sensor.

CAUTION

Installation of swing side sensor only:
Jumper X5-11 to X5-3.

Sensor Installation and Wiring Instructions

Table A21.1 BEA Superscan-T cable wiring swing side

Superscan-T function	Wire	Wire color	ED100/ED250	
Monitoring (+) Swing side	1	Purple/ Yellow	X5-17	Swing side test
Monitoring negative	2	Purple	X5-3	0V
n/c	3			
Relay N.O.	4	Blue	X5-15	Swing side presence signal
n/c	5			
Relay common	6	Brown	X5-3	0V
24V	7	Black	X5-3	0V
24V	8	Red	X5-1	+24

Table A2.1.2 BEA Superscan-T cable wiring approach side

Superscan-T function	Wire	Wire color	ED100/ED250	
Monitoring (+) Swing side	1	Purple/ Yellow	X5-13	Approach side test
Monitoring negative	2	Purple	X5-3	0V
n/c	3			
Relay N.O.	4	Green	X5-11	Approach side presence signal
n/c	5			
Relay common	6	White	X5-3	0V
24V	7	Black	X5-3	0V
24V	8	Red	X5-1	+24

Table A2.1.3 BEA Superscan-T jumper settings

Jumper	Function	Setting	Jumper
J1	Background analysis	Normal mode (Factory default)	Center and left pins
J2	Relay mode (NO /NC)	Relay active mode (Factory default) Relay energized when detector is powered, closed contact during detection.	Center and right pins (view looking toward P1)
J3	Monitoring mode	Monitoring On	Jumper removed or stored on one pin
J4	Master only or master and slave	As required	Refer to user manual

A2.1.1 Install and commission BEA Superscan-T sensors.

CAUTION

ED100/ED250 operator must have full learning cycle completed prior to sensor installation.

NOTICE

Confirm controller firmware is v2.1 or higher during learn cycle.

CAUTION

Refer to BEA Superscan T user manual for sensor installation, settings, learn, and operation checks.

CAUTION

Parameter **hd** (Door Closer Mode) must be set to **"1" Automatic** for sensor setup and tuning!

1. Configure BEA Superscan T jumpers per Table A2.1.2

Configure jumper J3 for Monitoring Mode.

2. Set ED100/ED250 controller parameters .

Parameter	Setting	Description
Configure ST based on number and location of Superscan-T sensors.		
ST	Safety Sensor Test 6	Sensor test on swing and approach sides, active-low
ST	Safety Sensor Test 5	Sensor test on approach side only, active-low
ST	Safety Sensor Test 4	Sensor test on swing side only, active-low

A3.1 BEA Bodyguard-T overhead presence sensor, single door swing side, low energy application

FIG. A3.1.1 BEA Bodyguard-T wiring

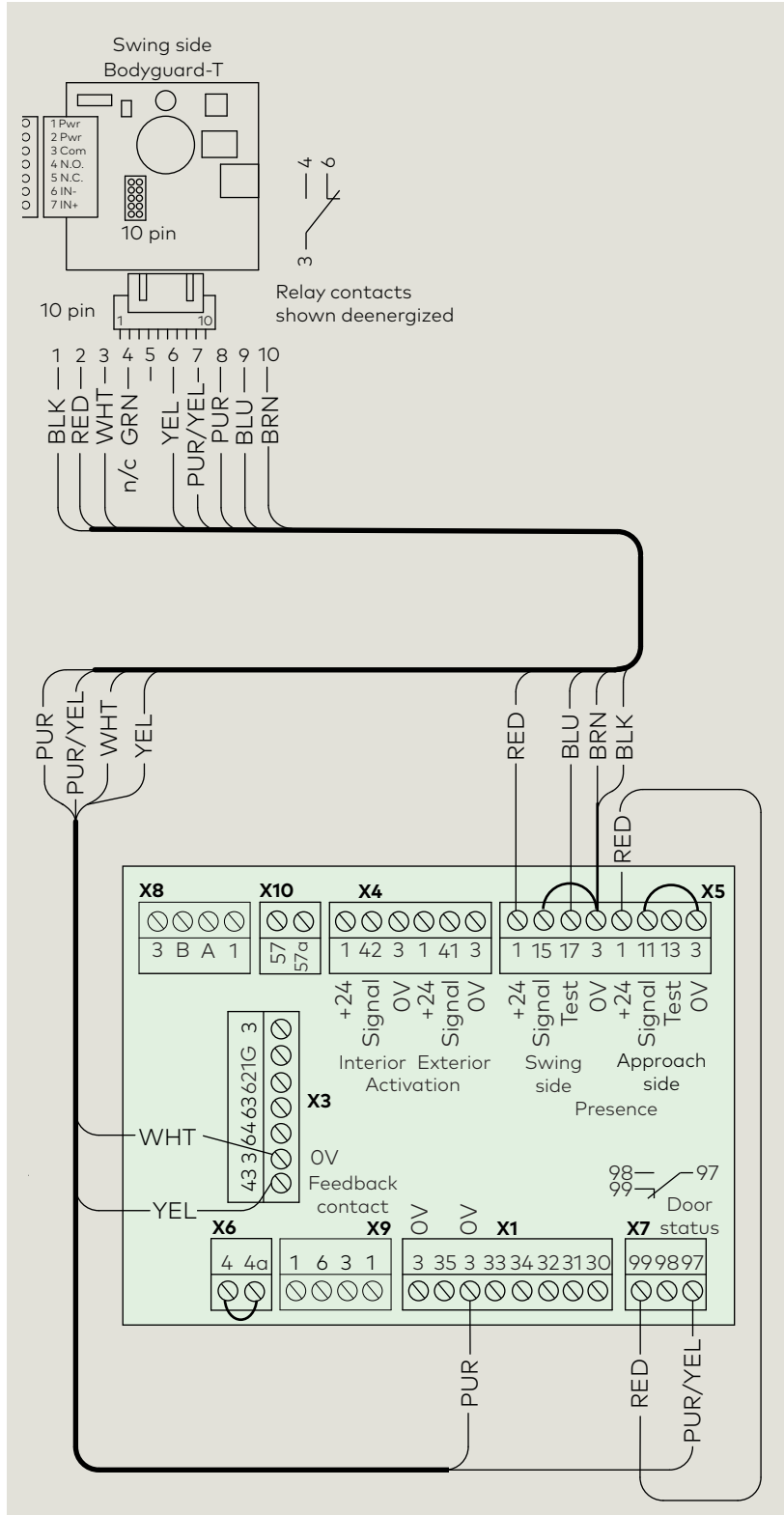

CAUTION

BEA Bodyguard T does not comply with requirements of ANSI/BHMA 156.10, Para. 8.2.2.2, as a stand-alone presence sensor.

Fig. A3.1.2 BEA Bodyguard-T safety zone, one way traffic

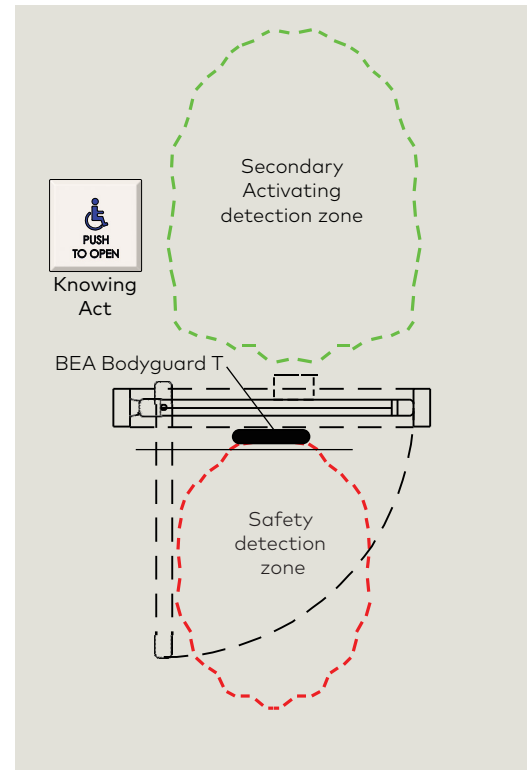

Sensor Installation and Wiring Instructions

Table A3.1.1 BEA Bodyguard-T wiring

Bodyguard-T function	Wire	Wire color	ED100/ED250	
24V	1	Red	X5-1	+24
24V	2	Blk	X5-3	0V
Relay Common	3	Wht	X3-3	0V
Relay N.O.	4	Green	n/c	
Empty	5			
Relay N.C.	6	Yellow	X3-43	Feedback signal
Monitoring (+)	7	Pur/Yel	X7-97	Relay common
Monitoring (-)	8	Pur	X1-3	0V
Data (+)	9	Blu	X5-17	Swing side test
Data (-)	10	Brn	X5-3	0V

A3.1.1 Install and commission BEA Bodyguard-T sensor.

CAUTION

ED100/ED250 operator must have full learning cycle completed prior to sensor installation.

NOTICE

Confirm controller firmware is v2.1 or higher during learn cycle.

CAUTION

Refer to BEA Bodyguard T user manual for sensor installation and setup.
Refer to Table A3.1.1 for wiring.

- Monitoring DIP switch**
Set BEA Bodyguard T Monitoring DIP switch ON.
- Install red wire from X5-1 to X7-99.
- Set ED100/ED250 controller parameters.

Parameter	Setting	Description
Configure ST based on number and location of Superscan-T sensors.		
ST	Safety Sensor Test	8 Sensor test, overhead sensor type Bodyguard II or Premier T with monitoring input.



TIPS AND RECOMMENDATIONS

Door status relay **X7, 97, 98, 99**.
Sr status relay function parameter = **1** (factory setting).
Status relay activated as soon as door reaches "closed" position.

A3.2 BEA Bodyguard-T overhead presence sensor, double door swing side, low energy application

FIG. A3.2.1 BEA Bodyguard-T wiring, double door

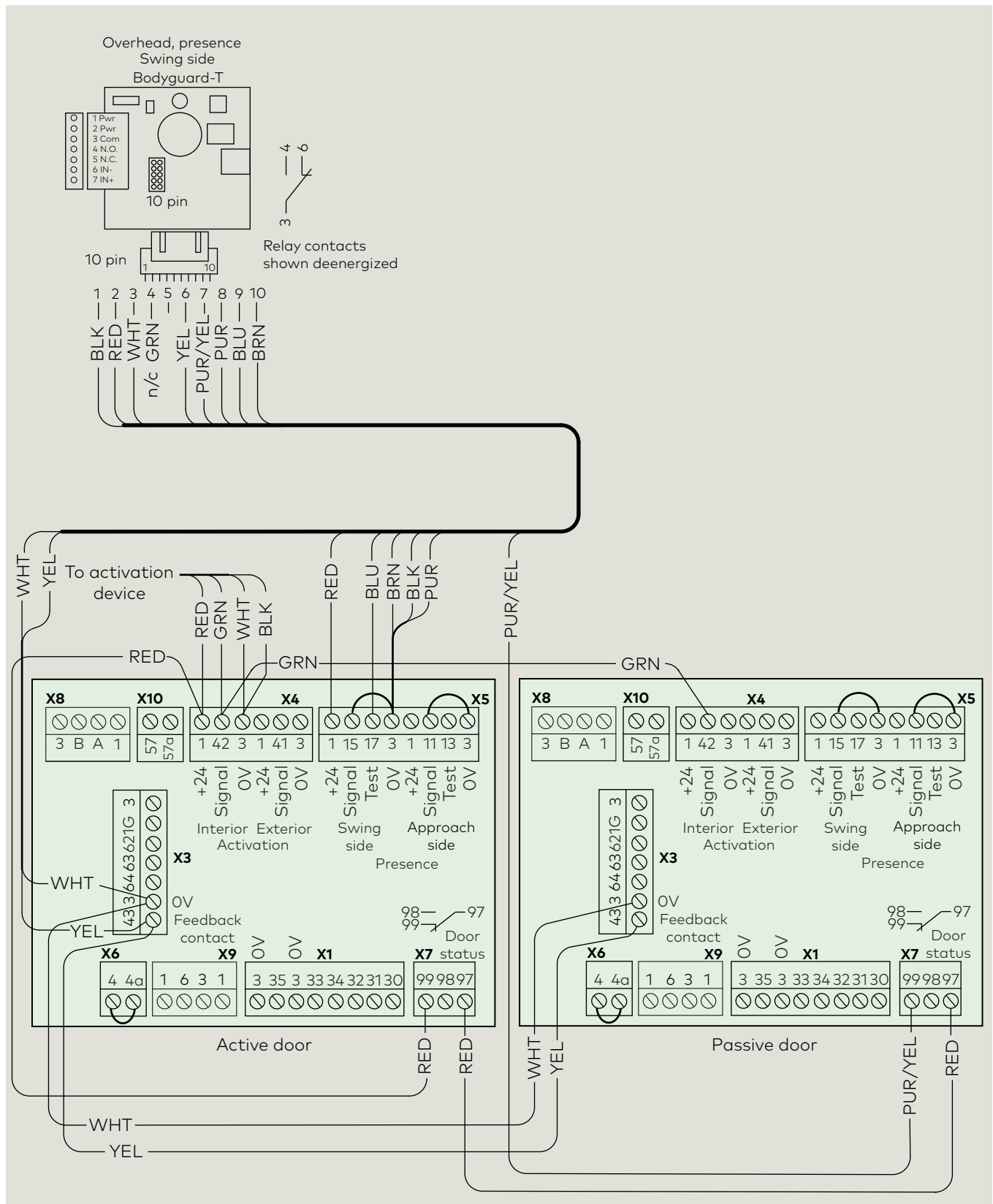

Sensor Installation and Wiring Instructions

Table A3.2.1 BEA Bodyguard-T wiring, active door

Bodyguard-T function	Wire	Wire color	ED250	
24V	1	Red	X5-1	+24
24V	2	Blk	X5-3	0V
Relay Common	3	Wht	X3-3	0V
Relay N.O.	4	Green	n/c	
Empty	5			
Relay N.C.	6	Yellow	X3-43	Feedback signal
Monitoring (-)	8	Pur	X5-3	0V
Data (+)	9	Blu	X5-17	Swing side test
Data (-)	10	Brn	X5-3	0V

Table A3.2.2 BEA Bodyguard-T wiring, passive door

Bodyguard-T function	Wire	Wire color	ED250	
Monitoring (+)	7	Pur/Yel	X7-99	Relay N/C

Fig. A3.2.2 BEA Bodyguard-T safety zone

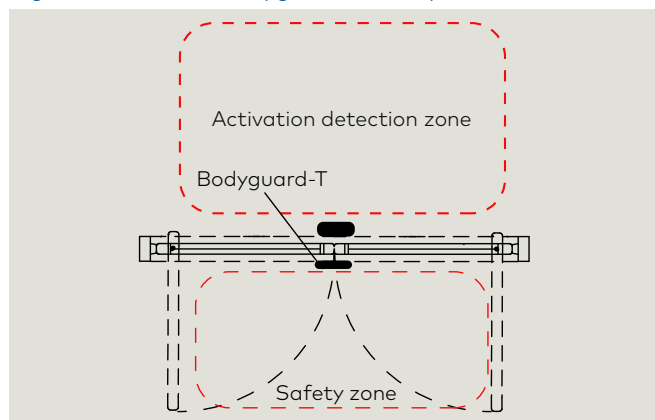

A3.2.1 Install and commission BEA Bodyguard-T sensor.

CAUTION

Both ED100/ED250 operators must have full learning cycle completed prior to sensor installation.

CAUTION

Parameter **dL** must be set to "0" on both ED100/ED250 operators for single door commissioning.

NOTICE

Confirm controller firmware is v2.1 or higher during learn cycle.

CAUTION

Refer to BEA Bodyguard T user manual for sensor installation and setup. Refer to Table A3.1.1 for wiring.

CAUTION

Parameter **hd** (Door Closer Mode) must be set to **"1" Automatic** for sensor setup and tuning!

1. **Monitoring DIP switch.**
Set BEA Bodyguard T Monitoring DIP switch ON.
2. Active door; Install red wire from X4-1 to X7-99.
3. White wire; install white wire from active door X3-0 to passive door X3-0.
4. Yellow wire; install yellow wire from active door X3-43 to passive door X3-43.
5. Green wire; Install green wire from active door X4-42 to passive door X4-42.
6. Set ED250 controller parameters.

Parameter	Setting	Description
Configure ST based on number and location of Superscan-T sensors.		
ST	Safety Sensor Test	8 Sensor test, overhead sensor type Bodyguard II or Premier T with monitoring input.



TIPS AND RECOMMENDATIONS

Door status relay **X7**, 97, 98, 99.
Sr status relay function parameter = **1** (factory setting).
Status relay activated as soon as door reaches "closed" position.

A3.3 BEA Bodyguard-T overhead presence sensor with Superscan-T door mounted swing side presence sensor, single door

FIG. A3.3.1 BEA Bodyguard-T and Superscan-T wiring

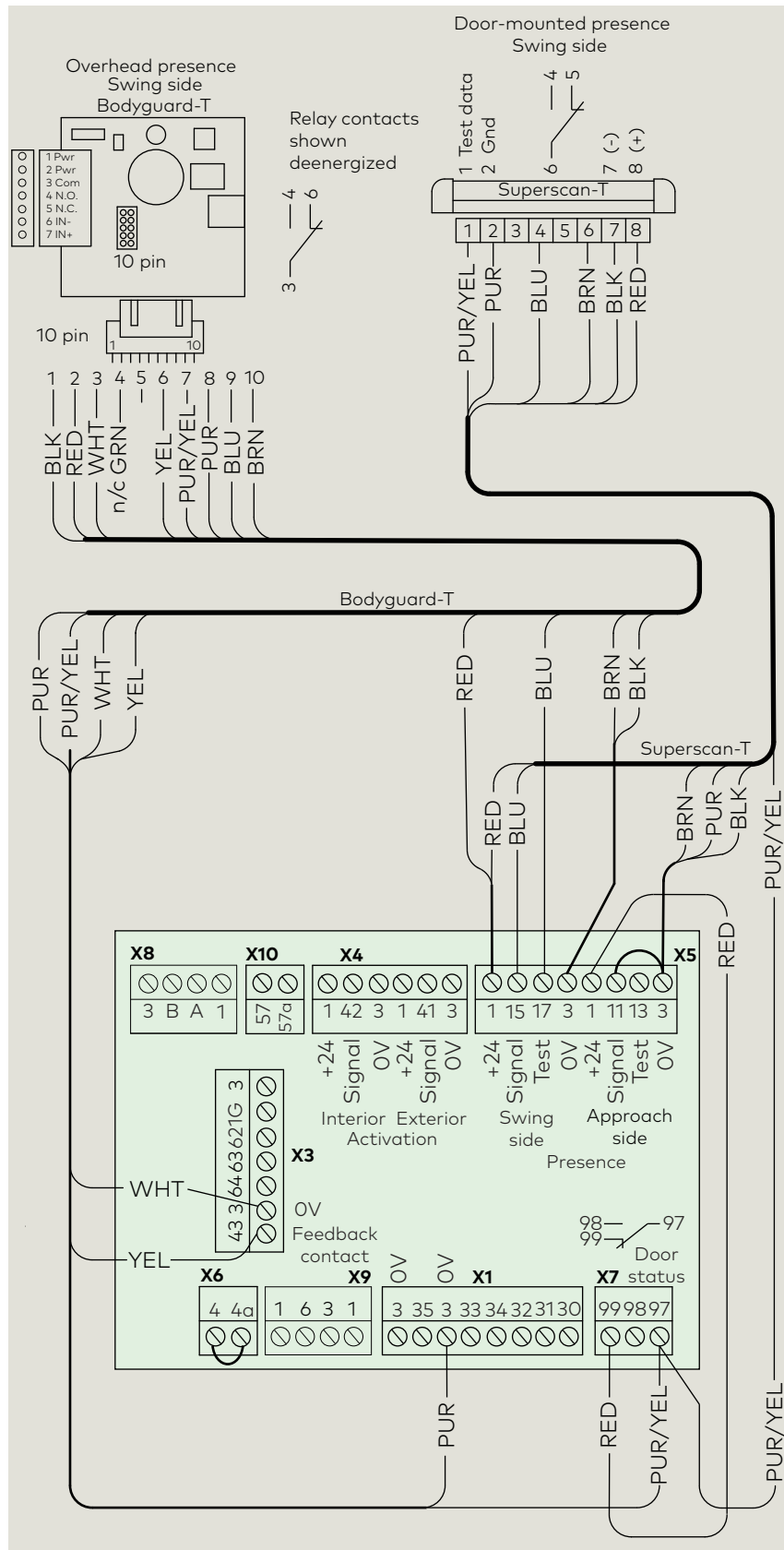
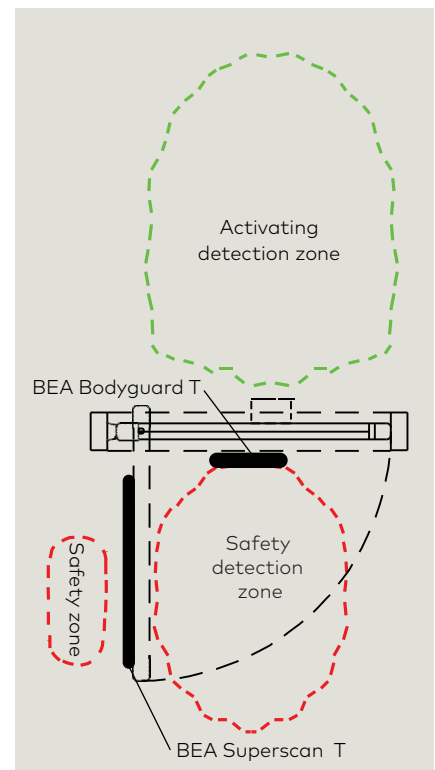

Fig. A3.3.2 BEA Bodyguard-T safety zone, swing side



Sensor Installation and Wiring Instructions

Table A3.3.1 BEA Bodyguard-T wiring

Bodyguard-T function	Pin.	Wire color	ED100/ED250	
24V	1	Red	X5-1	+24
24V	2	Blk	X5-3	0V
Relay Common	3	Wht	X3-3	0V
Relay N.O.	4	Green	n / c	
Empty	5			
Relay N.C.	6	Yellow	X3-43	Feedback contact
Monitoring (+)	7	Pur/Yel	X7-97	Door status relay common
Monitoring (-)	8	Pur	X1-3	0V
Data (+)	9	Blu	X5-17	Swing side test
Data (-)	10	Brn	X5-3	0V

NOTICE

Refer to Para. A2.1 for Superscan-T sensor setup.

Table A3.3.2 BEA Superscan-T wiring, swing side

Superscan-T function	Wire	Wire color	ED100/ED250	
Monitoring (+) swing side	1	Purple/Yellow	X7-97	Door status relay common
Monitoring negative	2	Purple	X5-3	0V
n/c	3			
Relay N.O.	4	Blue	X5-15	Swing side presence signal
n/c	5			
Relay common	6	Brown	X5-3	0V
24V	7	Black	X5-3	0V
24V	8	Red	X5-1	+24

A3.3.1 Install and commission BEA Bodyguard-T sensor.

CAUTION

ED100/ED250 operator must have full learning cycle completed prior to sensor installation.

NOTICE

Confirm controller firmware is v2.1 or higher during learn cycle.

CAUTION

Refer to BEA Bodyguard T user manual for sensor installation and setup.

1. Set BEA Bodyguard T Monitoring DIP switch ON.
2. Install red wire from X5-1 to X7-99.
3. Set ED100/ED250 controller parameters.

Parameter	Setting	Description
Configure ST based on number and location of Superscan-T sensors.		
ST	Safety Sensor Test	8 Sensor test, overhead sensor type Bodyguard II or Premier T with monitoring input.



TIPS AND RECOMMENDATIONS

Door status relay **X7, 97, 98, 99**.
Sr status relay function parameter = **1** (factory setting).
 Status relay activated as soon as door reaches "closed" position.

A3.4 BEA Bodyguard-T overhead presence sensor with Superscan-T door mounted presence and approach sensors, single door

FIG. A3.4.1 BEA Bodyguard-T and Superscan-T wiring

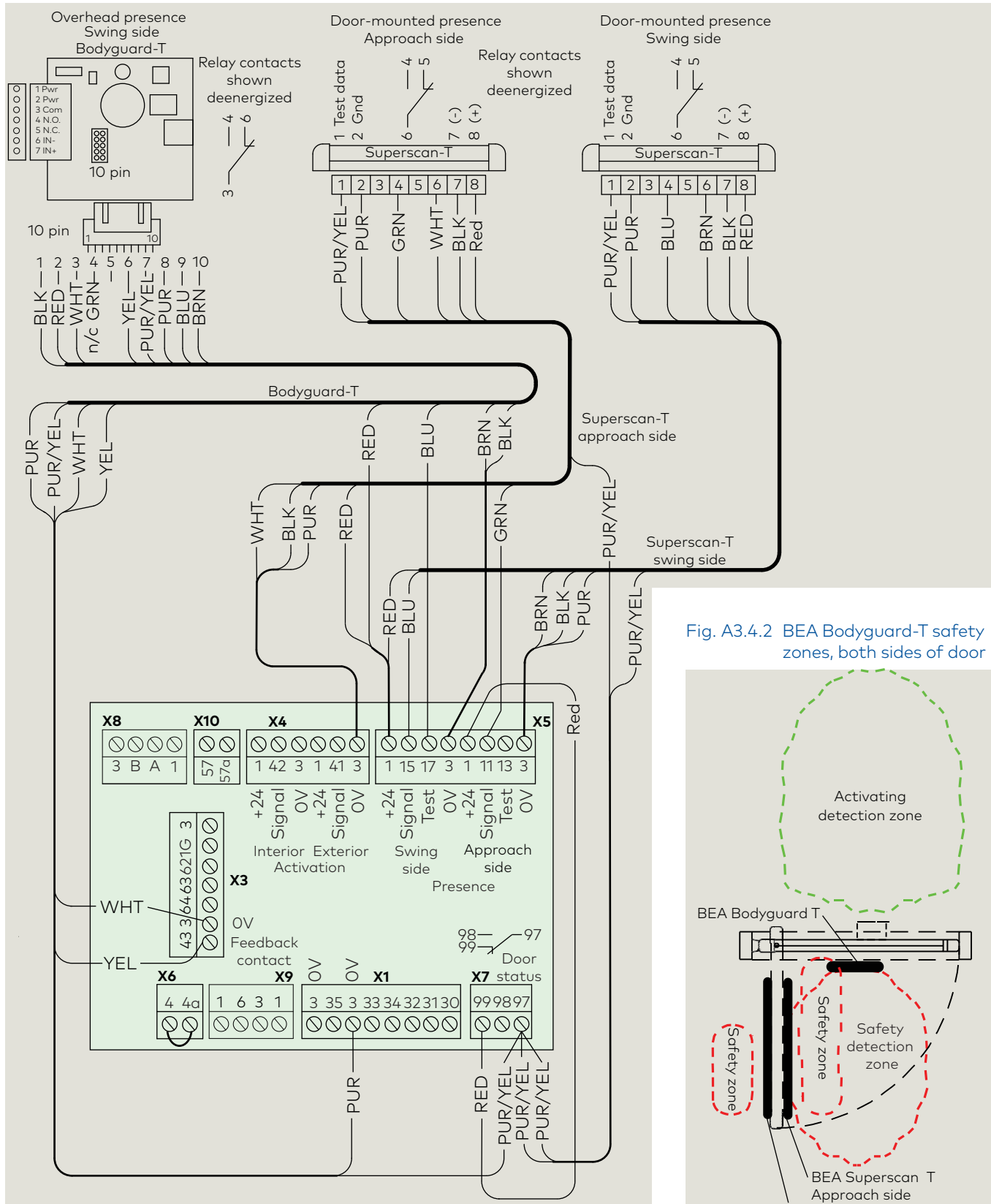
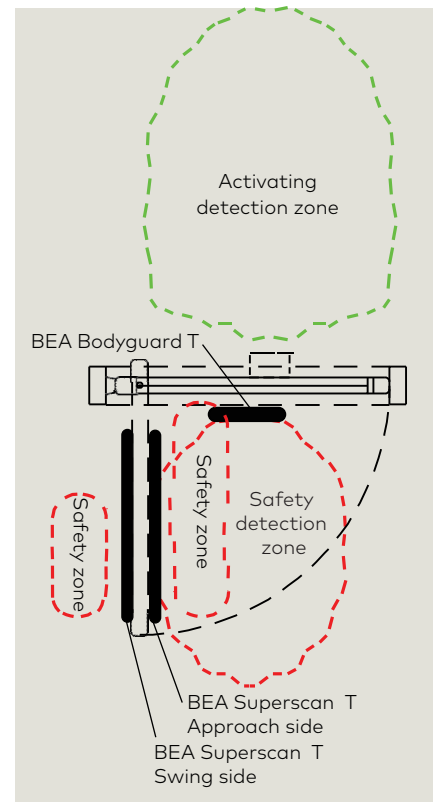

Fig. A3.4.2 BEA Bodyguard-T safety zones, both sides of door



Sensor Installation and Wiring Instructions

Table A3.4.1 BEA Bodyguard-T wiring

Bodyguard-T function	Pin.	Wire color	ED100/ED250	
24V	1	Red	X5-1	+24
24V	2	Blk	X5-3	0V
Relay Common	3	Wht	X3-3	0V
Relay N.O.	4	Green	n / c	
Empty	5			
Relay N.C.	6	Yellow	X3-43	Feedback contact
Monitoring (+)	7	Pur/Yel	X7-97	Door status relay common
Monitoring (-)	8	Pur	X1-3	0V
Data (+)	9	Blu	X5-17	Swing side test
Data (-)	10	Brn	X5-3	0V

NOTICE

Refer to Para. A2.1 for Superscan-T sensor setup.

Table A3.4.2 BEA Superscan-T wiring, swing side

Superscan-T function	Wire	Wire color	ED100/ED250	
Monitoring (+) swing side	1	Purple/Yellow	X7-97	Door status relay common
Monitoring negative	2	Purple	X5-3	0V
n/c	3			
Relay N.O., swing side	4	Blue	X5-15	Swing side presence signal
n/c	5			
Relay common, swing side	6	Brown	X5-3	0V
24V	7	Black	X5-3	0V
24V	8	Red	X5-1	+24

Table A3.4.3 BEA Superscan-T wiring, approach side

Superscan-T function	Wire	Wire color	ED100/ED250	
Monitoring (+) approach side	1	Purple/Yellow	X7-97	Door status relay common
Monitoring negative	2	Purple	X4-3	0V
n/c	3			
Relay N.O., approach side	4	Green	X5-11	Approach side presence signal
n/c	5			
Relay common, approach side	6	White	X4-3	0V
24V	7	Black	X4-3	0V
24V	8	Red	X5-1	+24

A3.4.1 Install and commission BEA Bodyguard-T sensor.

CAUTION

ED100/ED250 operator must have full learning cycle completed prior to sensor installation.

NOTICE

Confirm controller firmware is v2.1 or higher during learn cycle.

CAUTION

Refer to BEA Bodyguard T user manual for sensor installation and setup.

CAUTION

Parameter **hd** (Door Closer Mode) must be set to **"1" Automatic** for sensor setup and tuning!

1. Set BEA Bodyguard T Monitoring DIP switch ON.
2. Install red wire from X5-1 to X7-99.
3. Set ED100/ED250 controller parameters.

Parameter	Setting	Description
Configure ST based on number and location of Superscan-T sensors.		
ST	Safety Sensor Test	8 Sensor test, overhead sensor type Bodyguard II or Premier T with monitoring input.



TIPS AND RECOMMENDATIONS

Door status relay **X7**, 97, 98, 99.
Sr status relay function parameter = **1** (factory setting).
 Status relay activated as soon as door reaches "closed" position.

A3.5 BEA Bodyguard-T overhead presence sensor with Superscan-T door mounted swing and approach side presence sensors, pair

FIG. A3.5.1 BEA Bodyguard-T and Superscan-T wiring, door pair

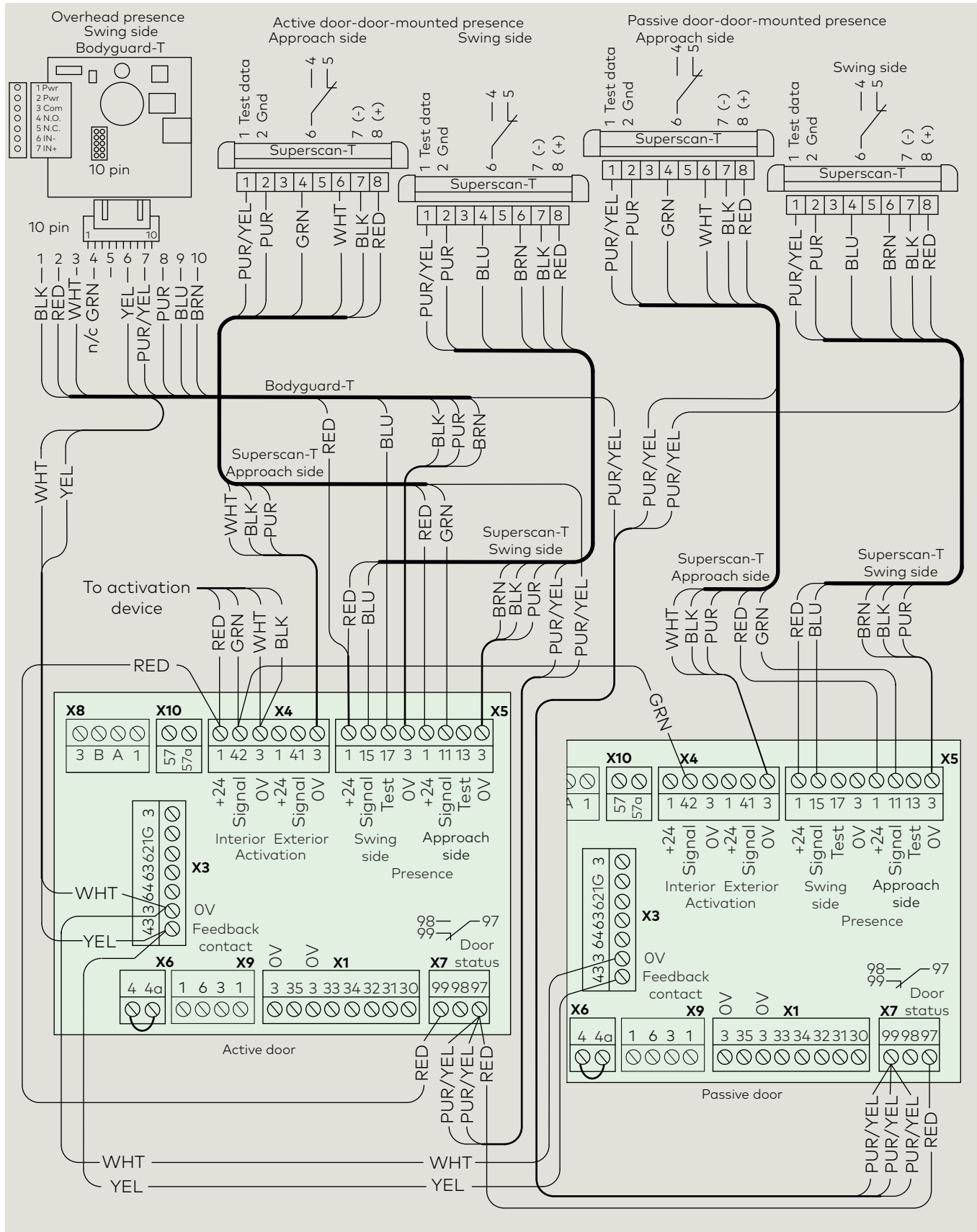

Sensor Installation and Wiring Instructions

Table A3.5.1 BEA Bodyguard-T wiring, active door

Bodyguard-T function	Pin.	Wire color	ED100/ED250
24V	1	Red	X5-1 +24
24V	2	Blk	X5-3 0V
Relay Common	3	Wht	X3-3 0V
Relay N.O.	4	Green	n / c
Empty	5		
Relay N.C.	6	Yellow	X3-43 Feedback contact
Monitoring (-)	8	Pur	X1-3 0V
Data (+)	9	Blu	X5-17 Swing side test
Data (-)	10	Brn	X5-3 0V

Table A3.5.2 BEA Bodyguard-T wiring, passive door

Bodyguard-T function	Pin.	Wire color	ED100/ED250
Monitoring (+)	7	Pur/Yel	X7-99 Door status relay common

NOTICE

Refer to Para. A2.1 for Superscan-T sensor setup.

Table A3.5.3 BEA Superscan-T wiring, swing side

Superscan-T function	Wire	Wire color	ED100/ED250
Monitoring (+) swing side	1	Purple/Yellow	X7-97 Door status relay common
Monitoring negative	2	Purple	X5-3 0V
n/c	3		
Relay N.O., swing side	4	Blue	X5-15 Swing side presence signal
n/c	5		
Relay common, swing side	6	Brown	X5-3 0V
24V	7	Black	X5-3 0V
24V	8	Red	X5-1 +24

Table A3.5.4 BEA Superscan-T wiring, approach side

Superscan-T function	Wire	Wire color	ED100/ED250
Monitoring (+) approach side	1	Purple/Yellow	X7-97 Door status relay common
Monitoring negative	2	Purple	X4-3 0V
n/c	3		
Relay N.O., approach side	4	Green	X5-11 Approach side presence signal
n/c	5		
Relay common, approach side	6	White	X4-3 0V
24V	7	Black	X4-3 0V
24V	8	Red	X5-1 +24

A3.5.1 Install and commission BEA Bodyguard-T sensor.

CAUTION

Both ED100/ED250 operators must have full learning cycle completed prior to sensor installation.

CAUTION

Parameter **dL** must be set to "0" on both ED100/ED250 operators for single door commissioning.

NOTICE

Confirm controller firmware is v2.1 or higher during learn cycle.

CAUTION

Refer to BEA Bodyguard T user manual for sensor installation and setup.

CAUTION

Parameter **hd** (Door Closer Mode) must be set to **"1" Automatic** for sensor setup and tuning!

1. Set BEA Bodyguard T Monitoring DIP switch ON.
2. Install red wire from X4-1 to X7-99, active door and from X7-97, active door to X7-97, inactive door.
3. Set ED100/ED250 controller parameters.

Parameter	Setting	Description
Configure ST based on number and location of Superscan-T sensors.		
ST	Safety Sensor Test	8 Sensor test, overhead sensor type Bodyguard II or Premier T with monitoring input.



TIPS AND RECOMMENDATIONS

Door status relay **X7**, 97, 98, 99. **Sr** status relay function parameter = **1** (factory setting).

FIG. A3.5.2 BEA Bodyguard-T and Superscan-T sensors

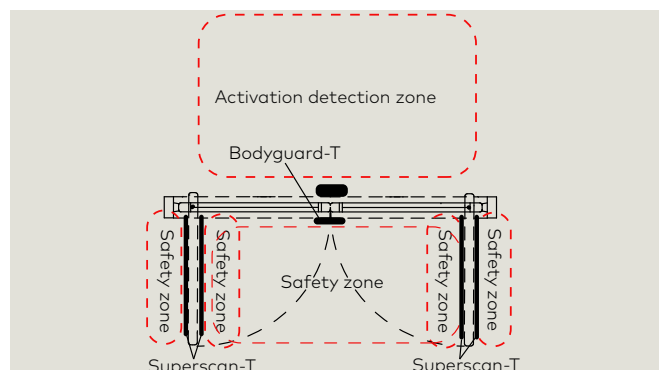

A3.6 BEA Bodyguard-T overhead presence sensor with Superscan-T door mounted swing side presence sensors, double door

FIG. A3.6.1 BEA Bodyguard-T and Superscan-T wiring

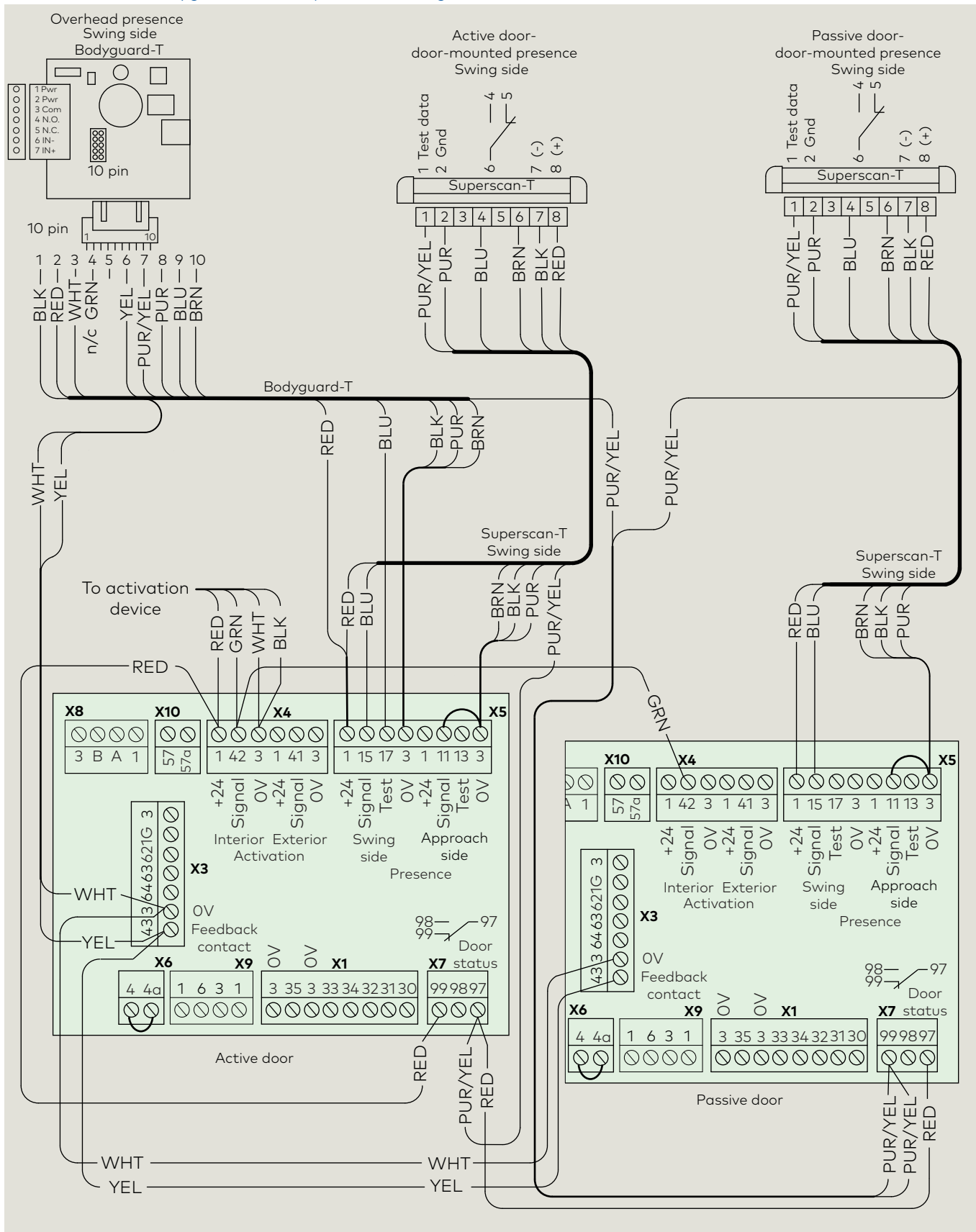

Sensor Installation and Wiring Instructions

Table A3.6.1 BEA Bodyguard-T wiring, active door

Bodyguard-T function	Pin.	Wire color	ED100/ED250	
24V	1	Red	X5-1	+24
24V	2	Blk	X5-3	0V
Relay Common	3	Wht	X3-3	0V
Relay N.O.	4	Green	n / c	
Empty	5			
Relay N.C.	6	Yellow	X3-43	Feedback contact
Monitoring (-)	8	Pur	X5-3	0V
Data (+)	9	Blu	X5-17	Swing side test
Data (-)	10	Brn	X5-3	0V

Table A3.6.2 BEA Bodyguard-T wiring, passive door

Bodyguard-T function	Pin.	Wire color	ED100/ED250	
Monitoring (+)	7	Pur/Yel	X7-99	Door status relay common

NOTICE

Refer to Para. A2.1 for Superscan-T sensor setup.

Table A3.6.3 BEA Superscan-T wiring, active door

Superscan-T function	Wire	Wire color	ED100/ED250	
Monitoring (+) swing side	1	Purple/Yellow	X7-97	Door status relay common
Monitoring negative	2	Purple	X5-3	0V
n/c	3			
Relay N.O., swing side	4	Blue	X5-15	Swing side presence signal
n/c	5			
Relay common, swing side	6	Brown	X5-3	0V
24V	7	Black	X5-3	0V
24V	8	Red	X5-1	+24

Table A3.6.4 BEA Superscan-T wiring, passive door

Superscan-T function	Wire	Wire color	ED100/ED250	
Monitoring (+) swing side	1	Purple/Yellow	X7-99	Door status relay common
Monitoring negative	2	Purple	X5-3	0V
n/c	3			
Relay N.O., swing side	4	Blue	X5-15	Swing side presence signal
n/c	5			
Relay common, swing side	6	Brown	X5-3	0V
24V	7	Black	X5-3	0V
24V	8	Red	X5-1	+24

A3.6.1 Install and commission BEA Bodyguard-T sensor.

CAUTION

Both ED100/ED250 operators must have full learning cycle completed prior to sensor installation.

CAUTION

Parameter **dL** must be set to "0" on both ED100/ED250 operators for single door commissioning.

NOTICE

Confirm controller firmware is v2.1 or higher during learn cycle.

CAUTION

Refer to BEA Bodyguard T user manual for sensor installation and setup.

1. Set BEA Bodyguard T Monitoring DIP switch ON.
2. Install red, green, white and yellow wires per Fig. 3.6.1.
3. Set ED100/ED250 controller parameters.

Parameter	Setting	Description
Configure ST based on number and location of Superscan-T sensors.		
ST	Safety Sensor Test	8 Sensor test, overhead sensor type Bodyguard II or Premier T with monitoring input.



TIPS AND RECOMMENDATIONS

Door status relay **X7**, 97, 98, 99.
Sr status relay function parameter = **1** (factory setting).
 Status relay activated as soon as door reaches "closed" position.

FIG. A3.6.2 BEA Bodyguard-T and Superscan-T sensors

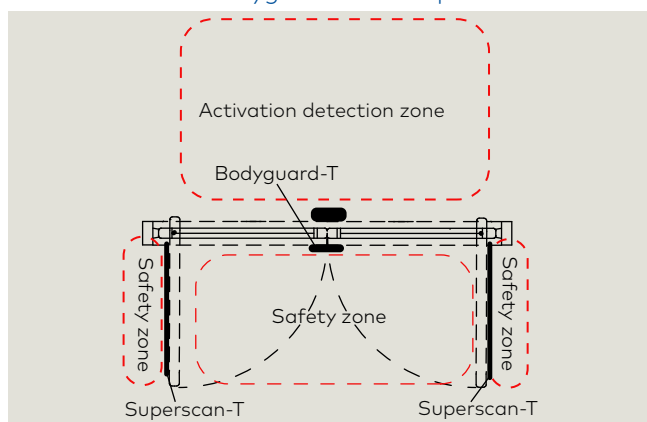

A4.1 BEA Eagle activation sensor

FIG. A4.1.1 BEA Eagle wiring

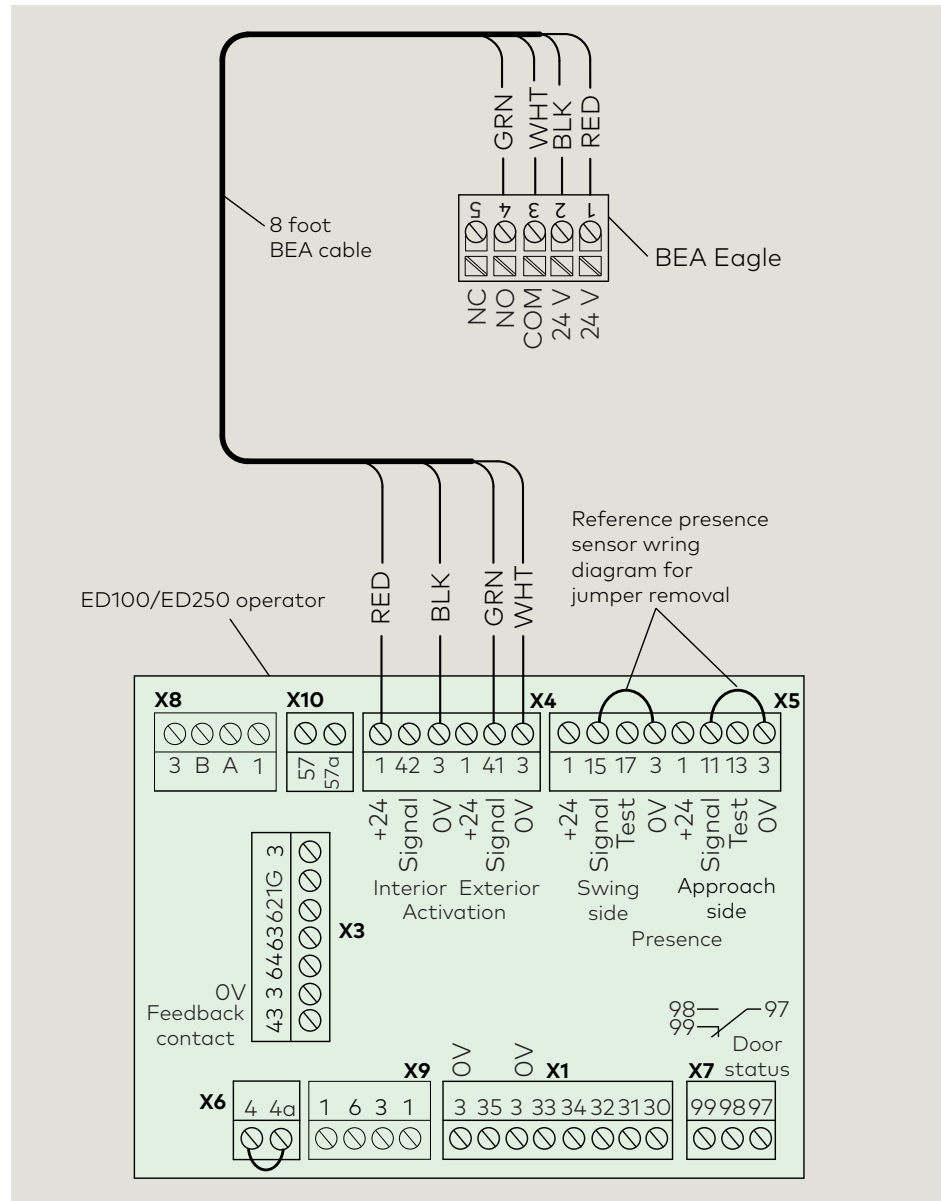
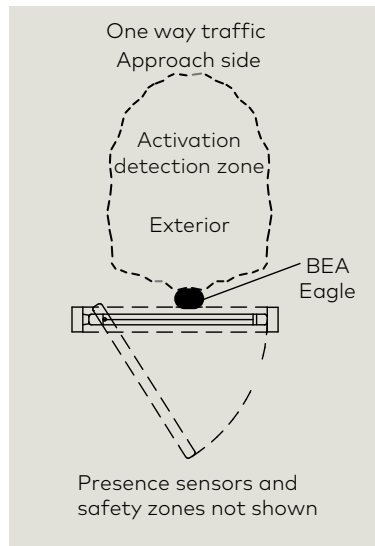

FIG. A4.1.2 Activation sensor



A4.1.1 BEA Eagle settings

Setting	Description	
Zone size	XL	Factory value
Immunity filter	Normal	Factory value
Detection mode	uni MTF	Factory value
Output configuration	A -active output (NO contact)	Factory value
Hold-open time	0.5s	Factory value
Mounting height	<10 ft.	Factory value
Door control	Factory value	Factory value

This page left intentionally blank.

A5.1 Optrix Elite T swing door mounted sensor - single door

Fig. A5.1.1 Optrix OC-904C T controller wiring diagram, single door

- 1 ED100/ED250 terminal board
- 2 OC-904C T controller
- 2.1 DIP switches
- 2.2 Operation indicator
- 2.3 Connector
- 2.4 Interface LED
- 2.5 Safety output hold timer
- 2.6 Stall output hold timer
- 2.7 Wiring cable
- 2.8 Sensor cable

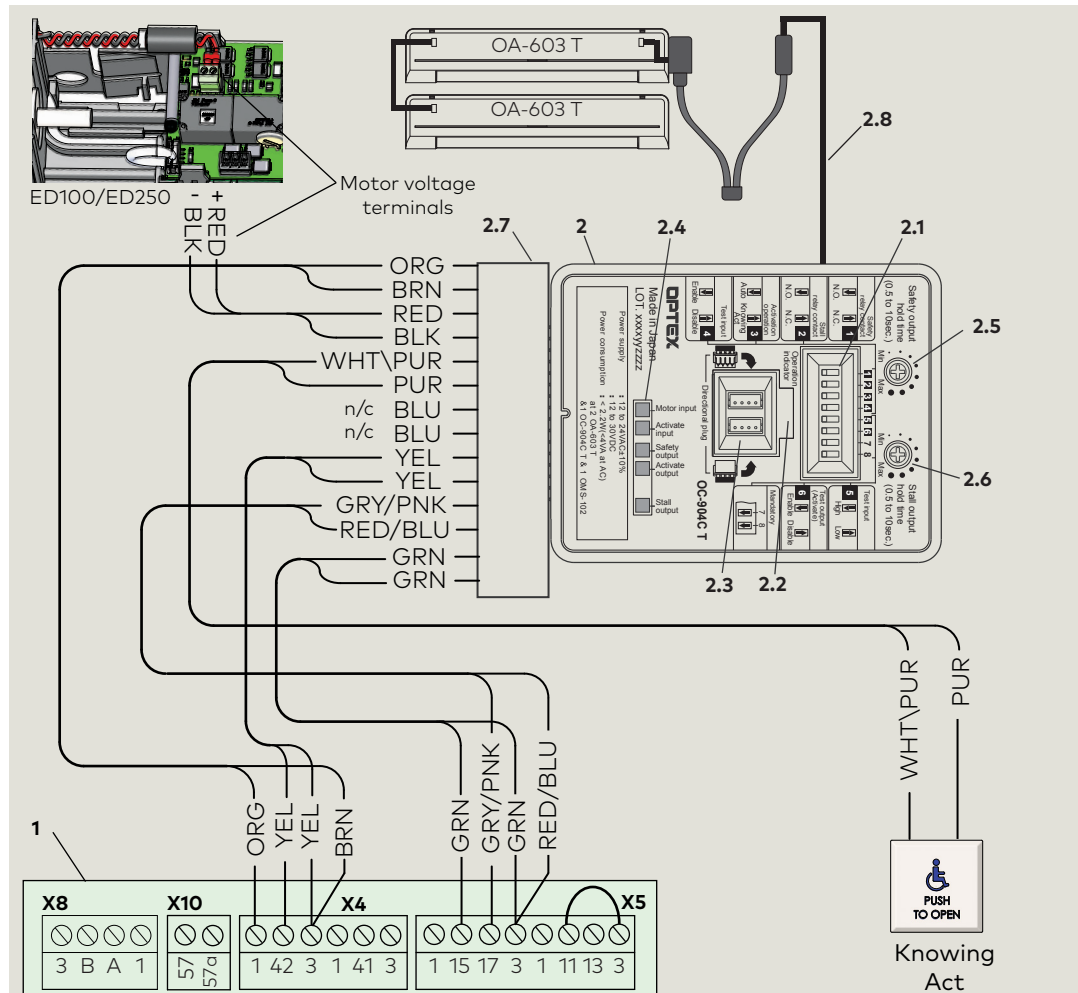

Fig. A5.1.2 Single door, two sensors

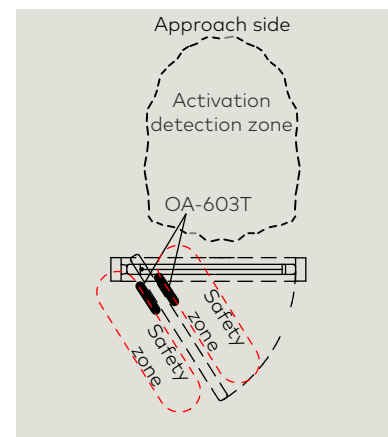

Table A5.1.1 Optex OC-904C T wire harness

Optex OC-904C T		ED100/ED250	
ORG	Power	X4-1	+24 V
BRN	Power	X4-3	0 V
RED	Motor voltage input (+)	+ motor terminal	
BLK	Motor voltage input (-)	-motor terminal	
WHT/PUR	Knowing act (+)	Knowing act device if used	
PUR	Knowing act (-)	Knowing act device if used	
BLU	Safety output	n/c	
BLU	Safety output	n/c	
YEL	Activate output	X4-42	Interior activation signal
YEL	Activate output	X4-3	0 V
GRY/PNK	Test input (+)	X5-17	Safety sensor swing side test
RED/BLU	Test input (-)	X5-3	0 V
GRN	Stall output	X5-15	Safety sensor swing side signal
GRN	Stall output	X5-3	0V

Fig. A5.1.3 Optex OC-904C T controller DIP switch

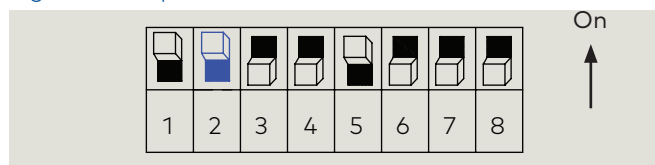

Table A5.1.2 Optex OC-904C T DIP switch

No.	Setting	Function
1	ON	N.C. Safety relay contact
2	ON	N.C. Stall relay contact
3	OFF	Auto Activation operation
3	ON	Knowing Act Knowing act operation
4	OFF	Enable Test input
5	ON	Low Test input level
6	OFF	Enable Test output (activate)
7	OFF	Mandatory OFF
8	OFF	Mandatory OFF

A5.1.1 Install and commission Optex Elite T sensor.

CAUTION

ED100/ED250 operator must have full learning cycle completed prior to sensor installation.

NOTICE

Confirm controller firmware is v2.1 or higher during learn cycle.

CAUTION

Refer to Optex Elite T and OC-904C T manuals for sensor installation and setup.

1. Set ED100/ED250 controller parameters for sensor installation and setup.

Parameter	Setting	Description
Configure ST based on number and location of Superscan-T sensors.		
ST	Safety Sensor Test	0 Test off.

2. Set final ED100/ED250 controller parameters after sensor installation and setup.

Parameter	Setting	Description
Configure ST based on number and location of Superscan-T sensors.		
ST	Safety Sensor Test	4 Sensor test on swing side, active-low.

A5.2 Optex Elite T swing door mounted sensor - double doors

A5.2.1 Wiring passive door sensors and controller

- 1 ED100/ED250 terminal board, active door
- 2 OC-904C T controller
- 2.1 DIP switches
- 2.2 Operation indicator
- 2.3 Connector
- 2.4 Interface LED
- 2.5 Safety output hold timer
- 2.6 Stall output hold timer
- 2.7 Wiring cable
- 2.8 Sensor cable
- 3 ED100/ED250 terminal board, inactive door
- 3.1 Activation input wires between controllers

1. Wire passive door controller the same as active door controller wiring shown in Fig. A5.2.1. For yellow wire installation between two operators, see step 2.
2. After ED100/ED250 commissioning (Para. A5.2.2) Install two yellow wires (3.1) between operators, terminals X4-42 and X4-3.

Fig. A5.2.1 Optex OC-904C T controller wiring diagram, double door

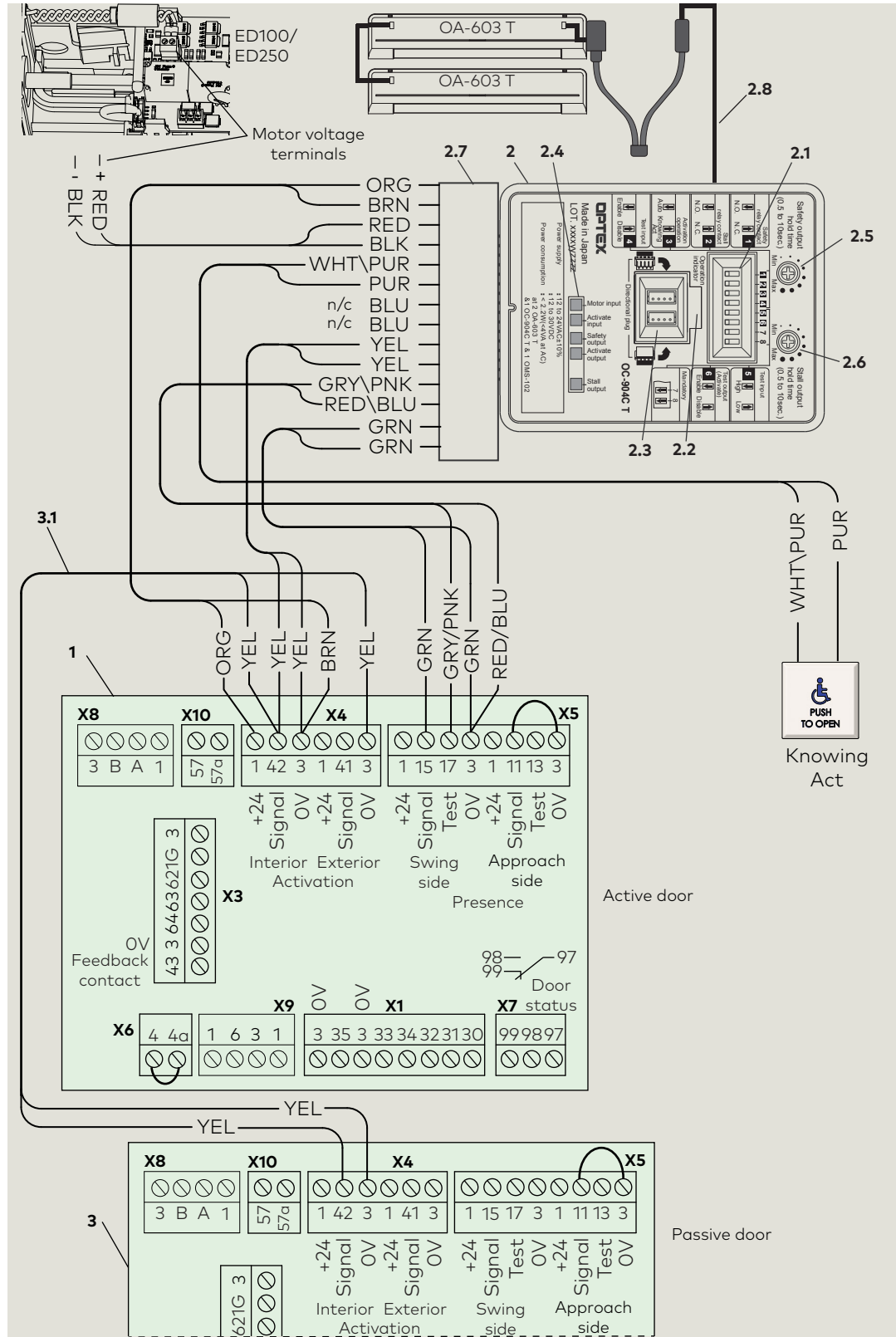

Sensor Installation and Wiring Instructions

Table A5.2.1 Optex OC-904C T wire harness

Optex OC-904C T		ED100/ED250	
ORG	Power	X4-1	+24 V
BRN	Power	X4-3	0 V
RED	Motor voltage input (+)	+ motor terminal	
BLK	Motor voltage input (-)	- motor terminal	
WHT/PUR	Knowing act (+)	Knowing act device if used	
PUR	Knowing act (-)	Knowing act device if used	
BLU	Safety output	Not used	
BLU	Safety output	Not used	
YEL	Activate output	X4-42	Interior activation signal
YEL	Activate output	X4-3	0 V
GRY/PNK	Test input (+)	X5-17	Safety sensor swing side test
RED/BLU	Test input (-)	X5-3	0 V
GRN	Stall output	X5-15	Safety sensor swing side signal
GRN	Stall output	X5-3	0 V

Fig. A5.2.2 Optex OC-904C T controller DIP switch

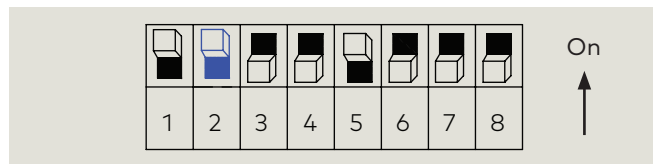

Table A5.2.3 Optex OC-904C T DIP switch

No.	Setting	Function
1	ON N.C.	Safety relay contact
2	ON N.C.	Stall relay contact
3	OFF Auto	Activation operation
3	ON Knowing Act	Knowing act operation
4	OFF Enable	Test input
5	ON Low	Test input level
6	OFF Enable	Test output (activate)
7	OFF Mandatory	OFF
8	OFF Mandatory	OFF

A5.2.1 Install and commission Optex Elite T sensors.

CAUTION

Both ED100/ED250 operators must have full learning cycle completed prior to sensor installation.

CAUTION

Parameter **dL** must be set to "0" on both ED100/ED250 operators for single door commissioning.

NOTICE

Confirm controller firmware is v2.1 or higher during learn cycle.

CAUTION

Refer to Optex Elite T and OC-904C T manuals for sensor installation and setup.

1. Set ED100/ED250 controller parameters for sensor installation and setup on each door.

Parameter	Setting	Description
Configure ST based on number and location of Superscan-T sensors.		
ST	Safety Sensor Test	0 Test off.

2. Refer to Para. A5.2.1 for double door sensor wiring.
3. Set final ED100/ED250 controller parameters after sensor installation and setup.

Parameter	Setting	Description
Configure ST based on number and location of Superscan-T sensors.		
ST	Safety Sensor Test	4 Sensor test on swing side, active-low.



TIPS AND RECOMMENDATIONS

If doors stay open indefinitely after completing yellow wire installation (Para. A5.2.1), reverse the connection of the two yellow wires (42 to 3, 3 to 42).

A6.1 Optex Premier T header mount presence sensor, single door, low energy application

- 1 Safety output hold timer
 - 2 Knowing act timer
 - 3 Lockout timer
 - 5 Operation indicator
 - 6 Connector
 - 7 Interface LED
- Activate input
Safety output
Activate output

Fig. A6.1.1 Optex Premier T sensor wiring

CAUTION

Optex Premier-T does not comply with requirements of ANSI/BHMA 156.10, Para. 8.2.2.2, as a stand-alone presence sensor.

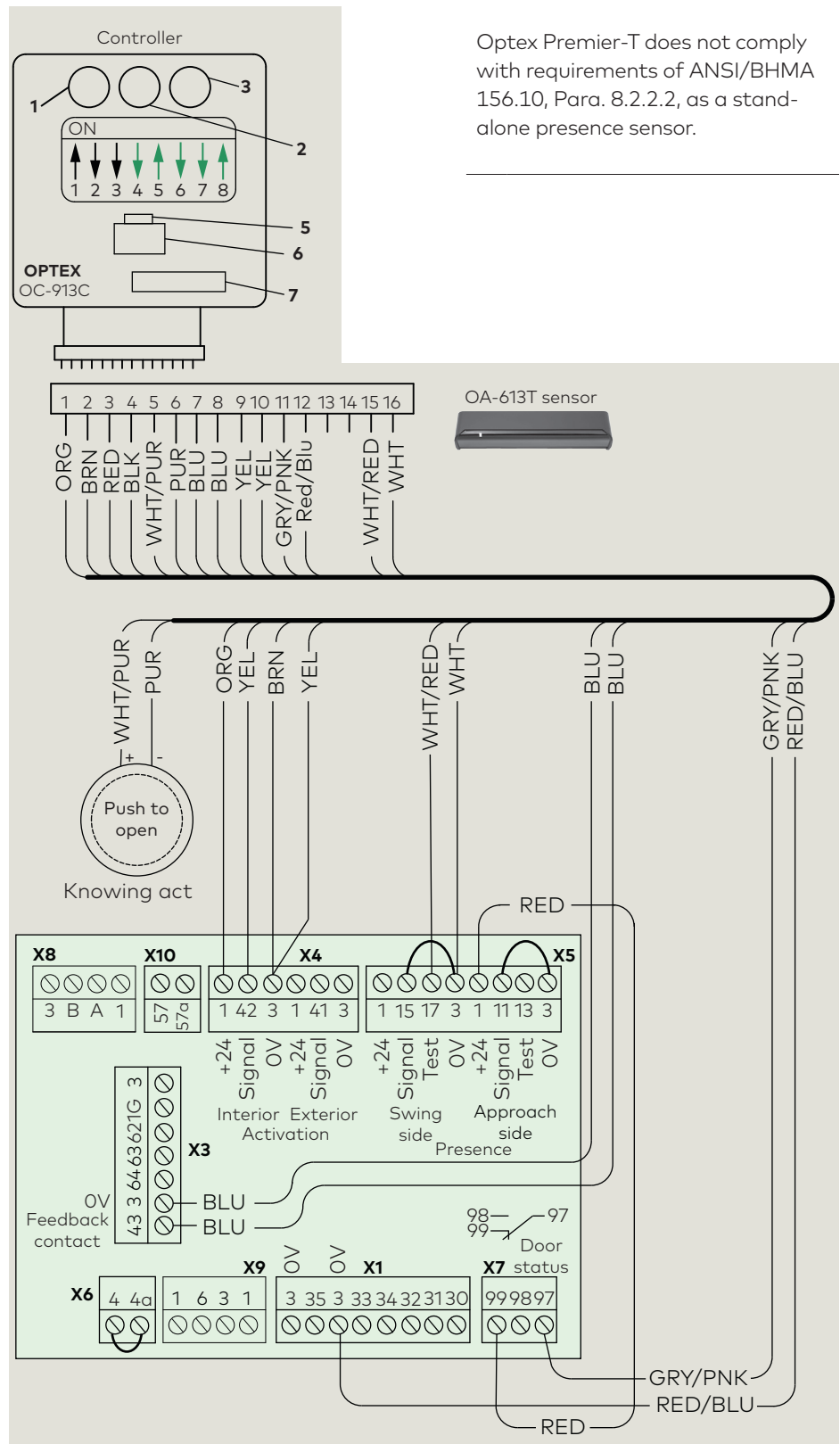
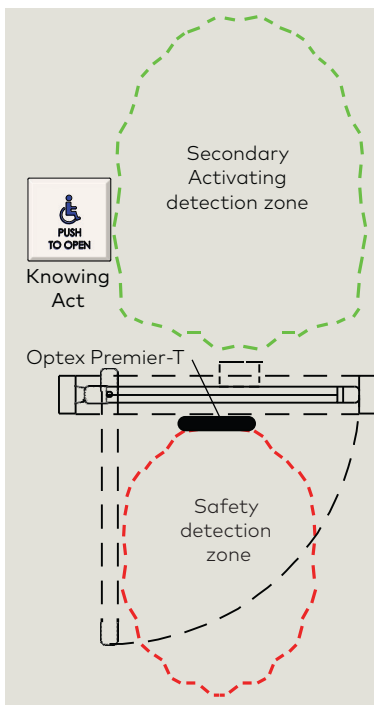

Fig. A6.1.2 Optex Premier T sensor zone



Add Optex OA Edge T to door swing side to meet A156.10 standard.

Sensor Installation and Wiring Instructions

Table A6.1.1 Optex OC-913C T wire harness

Optex OC-913C T			ED100/ED250	
1	ORG	Power	X4-1	+24 V
2	BRN	Power	X4-3	0 V
3	RED	Motor voltage input (+)	No connection	
4	BLK	Motor voltage input (-)	No connection	
5	WHT/ PUR	Activate input (+)	Knowing act	
6	PUR	Activate input (-)	Knowing act	
7	BLU	Safety output	X3-43	Feedback contact
8	BLU	Safety output	X3-3	0 V
9	YEL	Activate output	X4-42	Interior activation signal
10	YEL	Activate output	X4-3	0 V
11	GRY/ PNK	Test input (+)	X7-97	Safety sensor swing side test
12	RED/ BLU	Test input (-)	X1-3	0 V
13	n/a			
14	n/a			
15	WHT/ RED	Data input (+)	X5-17	Swing side test
16	WHT	Data input (-)	X5-3	0V

Table A6.1.2 Optex OC-913C T DIP switch

No.	Setting	Function
1	ON	N.C. Safety relay contact
2	OFF	Act. Door open signal switch
3	OFF	Auto -by motor voltage Auto lockout
4	OFF	Knowing Act No Knowing Act device
4	ON	Knowing Act If using Knowing Act device
5	ON	Data input Data output from door control for Lockout
6	OFF	PWM PWM from door control for Lockout
7	OFF	Test input Test output (activate) from door control
8	ON	Test input level Active low

A6.1.1 Install and commission Optex Premier-T sensor.

CAUTION

ED100/ED250 operator must have full learning cycle completed prior to sensor installation.

NOTICE

Confirm controller firmware is v2.1 or higher during learn cycle.

CAUTION

Refer to Optex Premier T installation manual for OA-613 T sensor and OC-913C T controller installation and setup.

1. Connect wires from connection cable to controller.
2. Connect red wire between X7-99 to X5-1.
3. Jumpers in place 15 to 3 and 11 to 3.
4. Set ED100/ED250 controller parameters for sensor installation and setup.

Parameter	Setting	Description
Configure ST based on number and location of Superscan-T sensors.		
ST	Safety Sensor Test	0 Test off.

5. Set final ED100/ED250 controller parameters after sensor installation and setup.

Parameter	Setting	Description
Configure ST based on number and location of Superscan-T sensors.		
ST	Safety Sensor Test	8 Sensor test, overhead sensor type Bodyguard III or Premier T with monitoring input.



TIPS AND RECOMMENDATIONS

Door status relay **X7**, 97, 98, 99.
Sr status relay function parameter = **1** (factory setting).
 Status relay activated as soon as door reaches "closed" position.

A6.2 Optex Premier T header mount presence sensor, door pair with Optex OA-EDGE-T door mounted swing side presence sensors

Fig. A6.2.1 Optex Premier T sensor wiring with OA-EDGE-T door mounted swing side presence sensors

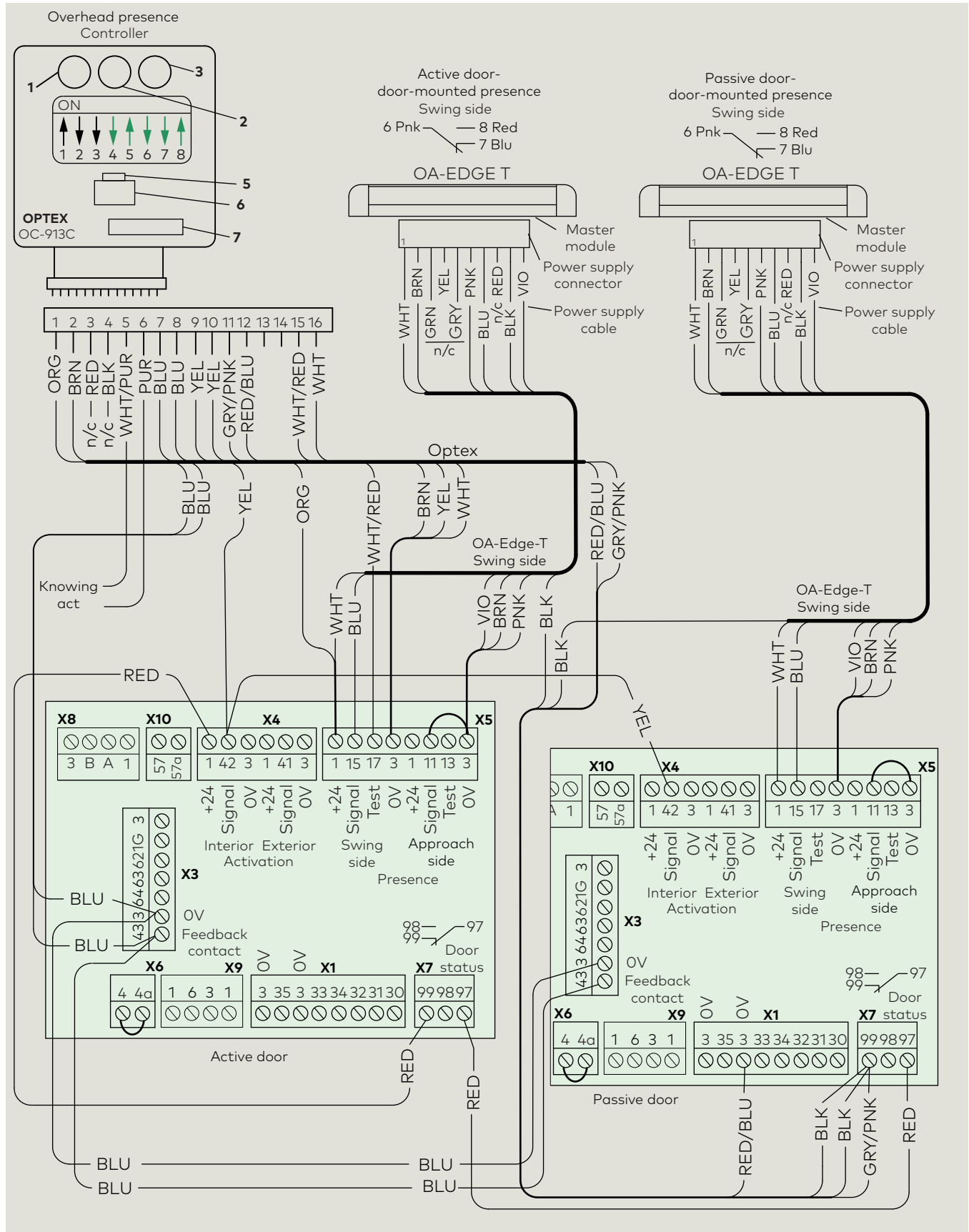

Sensor Installation and Wiring Instructions

Table A6.2.1 Optex OC-913C T wire harness, active door

Optex OC-913C T			ED100/ED250	
1	ORG	Power	X5-1	+24 V
2	BRN	Power	X5-3	0 V
3	RED	Motor voltage input (+)	No connection	
4	BLK	Motor voltage input (-)	No connection	
5	WHT/ PUR	Activate input (+)	Knowing act	
6	PUR	Activate input (-)	Knowing act	
7	BLU	Safety output	X3-43	Feedback contact
8	BLU	Safety output	X3-3	0 V
9	YEL	Activate output	X4-42	Connects to Inactive door. Interior activation signal
10	YEL	Activate output	X5-3	Connects to Inactive door. 0 V
11	GRY/ PNK	Test input (+)	X7-99	Active door Safety sensor swing side test
12	RED/ BLU	Test input (-)	X1-3	Active door 0 V
13	n/a			
14	n/a			
15	WHT/ RED	Data input (+)	X5-17	Swing side test
16	WHT	Data input (-)	X5-3	0V

Table A6.2.2 Optex OC-913C T DIP switch

No.	Setting	Function
1	ON	N.C. Safety relay contact
2	OFF	Act. Door open signal switch
3	OFF	Auto -by motor voltage Auto lockout
4	OFF	Knowing Act No Knowing Act device
4	ON	Knowing Act If using Knowing Act device
5	ON	Data input Data output from door control for Lockout
6	OFF	PWM PWM from door control for Lockout
7	OFF	Test input Test output (activate) from door control
8	ON	Test input level Active low

A6.2.1 Install and commission Optex Premier-T sensor.

CAUTION

ED100/ED250 operator must have full learning cycle completed prior to sensor installation.

CAUTION

Parameter **dL** must be set to "0" on both ED100/ED250 operators for single door commissioning.

NOTICE

Confirm controller firmware is v2.1 or higher during learn cycle.

NOTICE

Refer to Para. A7.2 for Optex OA-EDGE T wiring and installation.

CAUTION

Refer to Optex Premier T installation manual for OA-613 T sensor and OC-913C T controller installation and setup.

1. Connect wires from connection cable to controller.
2. Connect controller terminals X7-99 to X5-1.
3. Jumpers in place 15 to 3 and 11 to 3.
4. Set ED100/ED250 controller parameters for sensor installation and setup.

Parameter	Setting	Description
Configure ST based on number and location of Superscan-T sensors.		
ST	Safety Sensor Test	0 Test off.

5. Set final ED100/ED250 controller parameters after sensor installation and setup.

Parameter	Setting	Description
Configure ST based on number and location of Superscan-T sensors.		
ST	Safety Sensor Test	8 Sensor test, overhead sensor type Bodyguard III or Premier T with monitoring input.



TIPS AND RECOMMENDATIONS

Door status relay **X7, 97, 98, 99**.
Sr status relay function parameter = **1** (factory setting).
 Status relay activated as soon as door reaches "closed" position.

A7.1 Optex OA-Edge T door mounted presence sensors, swing and approach sides, one-way traffic

Fig. A7.1.1 Optex OA-Edge T sensor wiring

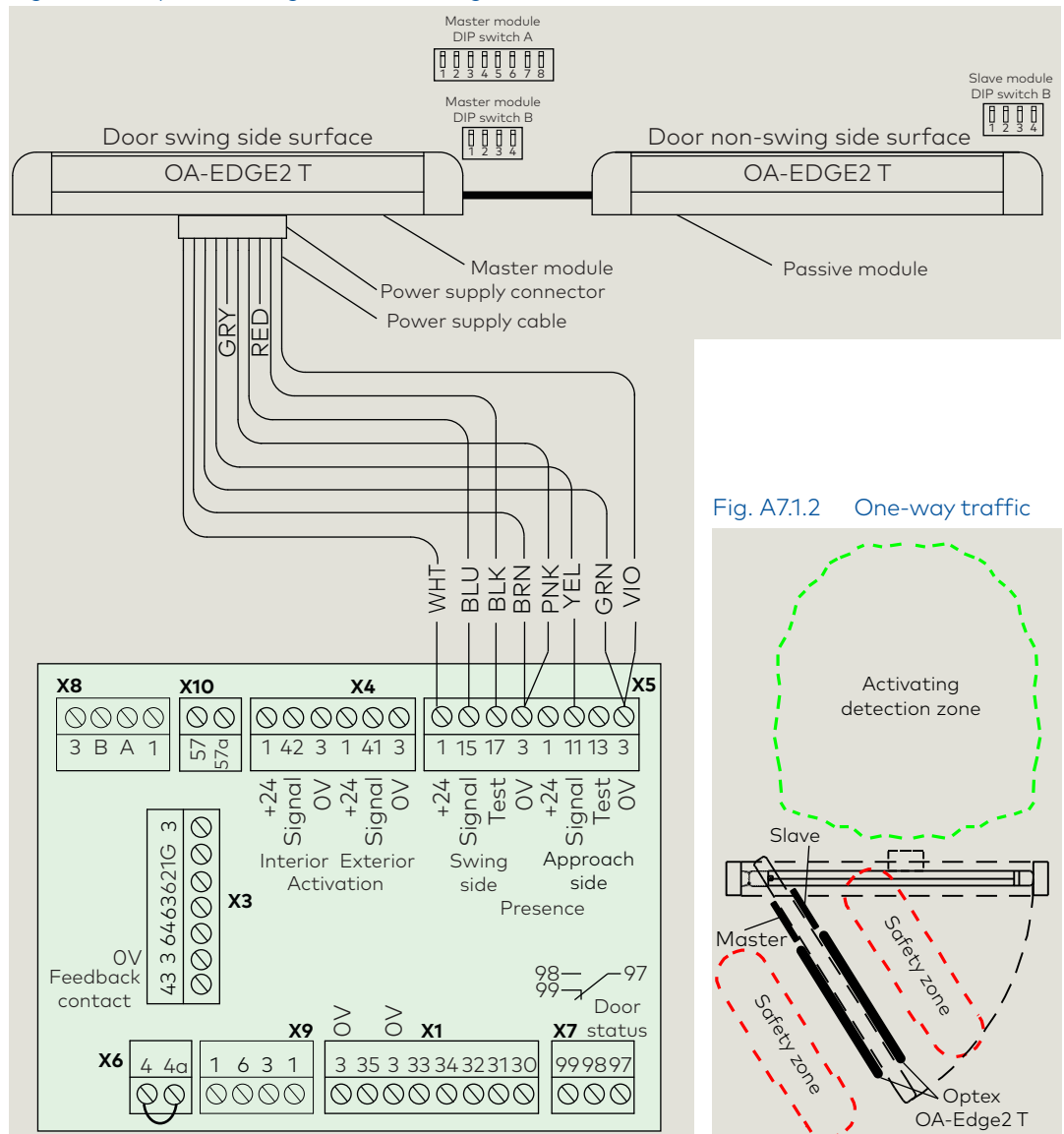

Fig. A7.1.2 One-way traffic

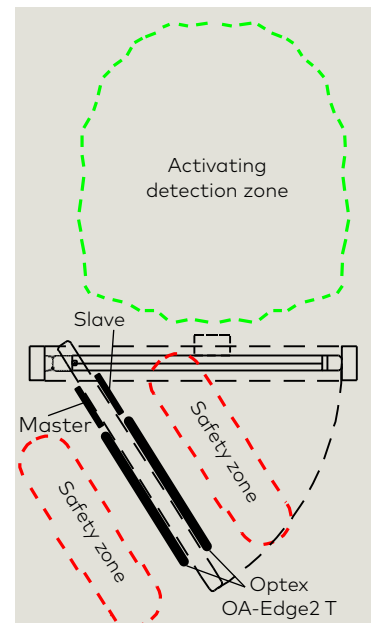

Table A7.1.1 Optex OA-Edge1T wiring

Bodyguard-T function	Pin	Wire color	ED100/ED250
24V (+)	1	Wht	X5-1 +24
24V (-)	2	Brn	X5-3 0v
Safety Output 2	Approach side (reactivate)		
Relay common	3	Grn	X5-3 0V
Relay N.C.	4	Yel	X5-11 Presence approach side
Relay N.O.	5	Gry	n/c
Safety Output 1	Swing side (stall)		
Relay common	6	Pnk	X5-3
Relay N.C.	7	Blu	X5-15 Presence swing side
Relay N.O.	8	Red	n/c
Test input (+)	9	Blk	X5-17 Swing side test
Test input (-)	9	Vio	X5-3 0V

A7.1.1 Install and commission Optex OA Edge T sensors.

CAUTION

ED100/ED250 operator must have full learning cycle completed prior to sensor installation.

NOTICE

Confirm controller firmware is v2.1 or higher during learn cycle.

1. Connect wires from power supply cable to controller. Refer to Fig. A7.1.1 and Table A71.1.
2. Remove jumpers from X5-11 and 3, X5-15 and 3.

CAUTION

Refer to Optex OA-Edge1 T / OA-Edge2 T operation manual for sensor installation, settings, initialization and learning.

CAUTION

Parameter **hd** (Door Closer Mode) must be set to **"1" Automatic** for sensor setup and tuning!

3. Set Master module DIP switch A.

Master DIP switch A function	No.	Setting	Description
Non detection zone (A)	A1	On/Off	Non-detection zone; set in conjunction with DIP switch B as required to meet standards.
Frequency	A2	Off	For double doors; set each sensor's DIP switch differently.
Immunity	A3	Off	Set A3 to On when sensor operates by itself (ghosting).
Presence timer	A4 A5	On/Off	Set as required for sensor to function.
Future use	A6		
Test input	A7	On	Active low
Test input delay	A8	On	Test input delay time: 20 msec.

4. Set Master module DIP switch B.

Master DIP switch B Function	No.	Setting	Description
Non detection zone (B)	B1	On/Off	Non-detection zone; set in conjunction with DIP switch A as required to meet standards.
Area width	B2	On/Off	Set B2 to ON (2 spots) when narrow detection area is required.
Self monitoring mode	B3	On	Setting for USA.
Sensor side (output select)	B4	Off	Swing side Safety output 1, LED Solid Red (detection)

5. Set Passive module DIP switch B

Passive DIP switch B function	No.	Setting	Description
Non detection zone (B)	B1	On/Off	Non-detection zone; set in conjunction with DIP switch A as required to meet standards.
Area width	B2	On/Off	Set B2 to ON (2 spots) when narrow detection area is required.
Self monitoring mode	B3	On	Setting for USA.
Sensor side (output select)	B4	On	Non-swing side Safety output 2, LED Solid Orange (detection)

6. Set ED100/ED250 controller parameters for sensor initialization.

Parameter	Setting	Description
ST Safety Sensor Test	0	Sensor test off.

7. Initialize sensor per Optex operation manual.

8. ED100/ED250 parameter final settings.

Parameter	Setting	Description
ST Safety Sensor Test	4	Sensor test on swing side, active-low

A7.2 Optex OA-Edge T door mounted presence sensor, single door, swing side, low energy application

Fig. A7.2.1 Optex OA-Edge T sensor wiring, swing side

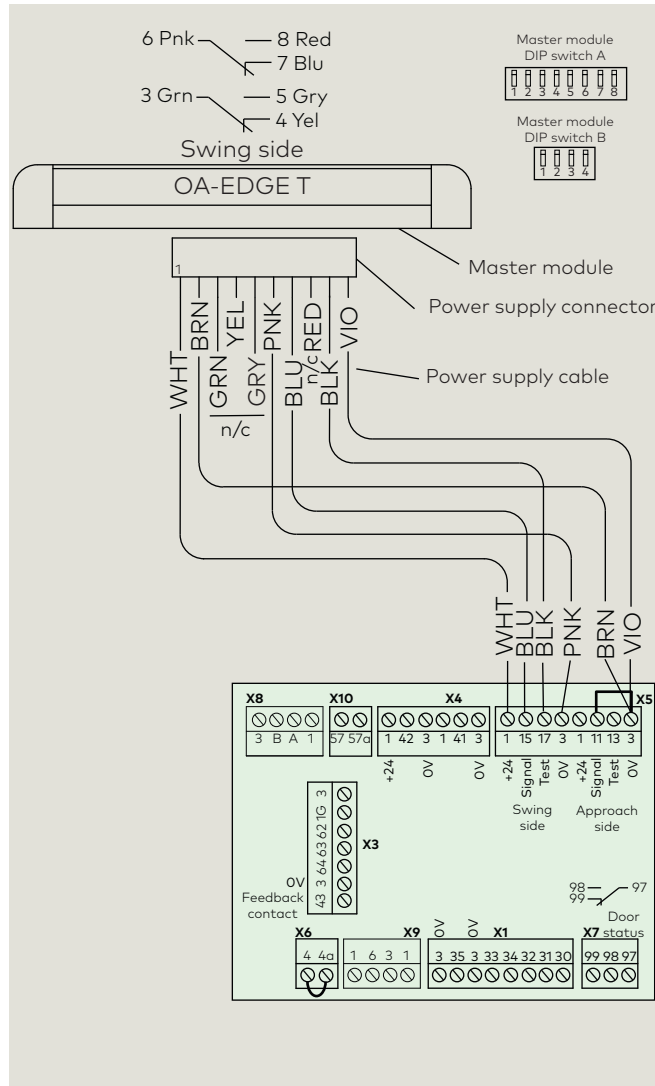

CAUTION

As shown, the Optex OA-Edge T does not comply with requirements of ANSI/BHMA 156.10, Para. 8.2.2.2, as a stand-alone presence sensor.

Fig. A7.2.2 One-way traffic

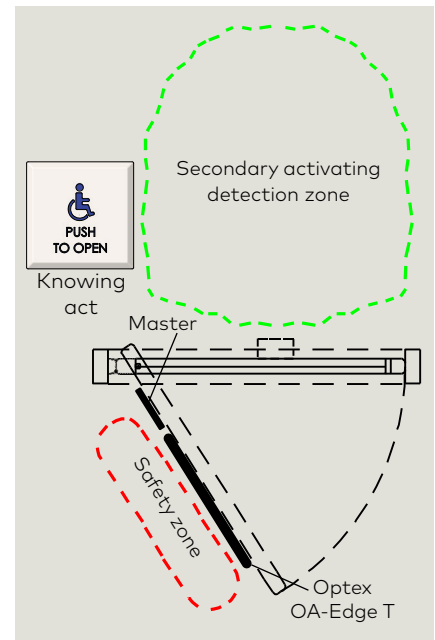

Table A7.2.1 Optex OA-Edge1 T wiring, swing side

Bodyguard-T function	Pin	Wire color	ED100/ED250	
24V (+)	1	Wht	X5-1	+24
24V (-)	2	Brn	X5-3	0v
Safety Output 2			Approach side (reactivate)	
Relay common	3	Grn	n/c	
Relay N.C.	4	Yel	n/c	
Relay N.O.	5	Gry	n/c	
Safety Output 1			Swing side (stall)	
Relay common	6	Pnk	X5-3	0V
Relay N.C.	7	Blu	X5-15	Presence swing side
Relay N.O.	8	Red	n/c	
Test input (+)	9	Blk	X5-17	Swing side test
Test input (-)	9	Vio	X5-3	0V

A7.2.1 Install and commission Optex OA Edge T swing side sensor.

CAUTION

ED100/ED250 operator must have full learning cycle completed prior to sensor installation.

NOTICE

Confirm controller firmware is v2.1 or higher during learn cycle.

1. Connect wires from power supply cable to controller. Refer to Fig. A7.2.1 and Table A7.2.1.
2. Jumper in place X5-11 to 3.
3. Remove jumper from X5-15 to 3.

CAUTION

Refer to Optex OA-Edge1 T / OA-Edge2 T operation manual for sensor installation, settings, initialization and learning.

4. Set Master module DIP switch A.

Master DIP switch A function	No.	Setting	Description
Non detection zone (A)	A1	On/Off	Non-detection zone; set in conjunction with DIP switch B as required to meet standards.
Frequency	A2	Off	For double doors; set each sensor's DIP switch differently.
Immunity	A3	Off	Set A3 to On when sensor operates by itself (ghosting).
Presence timer	A4 A5	On/Off	Set as required for sensor to function.
Future use	A6		
Test input	A7	On	Active low
Test input delay	A8	On	Test input delay time: 20 msec.

5. Set Master module DIP switch B.

Master DIP switch B Function	No.	Setting	Description
Non detection zone (B)	B1	On/Off	Non-detection zone; set in conjunction with DIP switch A as required to meet standards.
Area width	B2	On/Off	Set B2 to ON (2 spots) when narrow detection area is required.
Self monitoring mode	B3	On	Setting for USA.

Sensor side (output select)	B4	Off	Swing side	Safety output 1, LED Solid Red (detection)
-----------------------------	----	-----	------------	--

6. Set ED100/ED250 controller parameters for sensor initialization.

Parameter	Setting	Description
ST Safety Sensor Test	0	Sensor test off.

7. Initialize sensor per Optex operation manual.

8. ED100/ED250 parameter final settings:

Parameter	Setting	Description
ST Safety Sensor Test	4	Sensor test on swing side.- active-low

A7.3 Optex OA-Edge T door mounted presence sensor, single door, approach side, low energy application

Fig. A7.2.1 Optex OA-Edge T sensor wiring, approach side

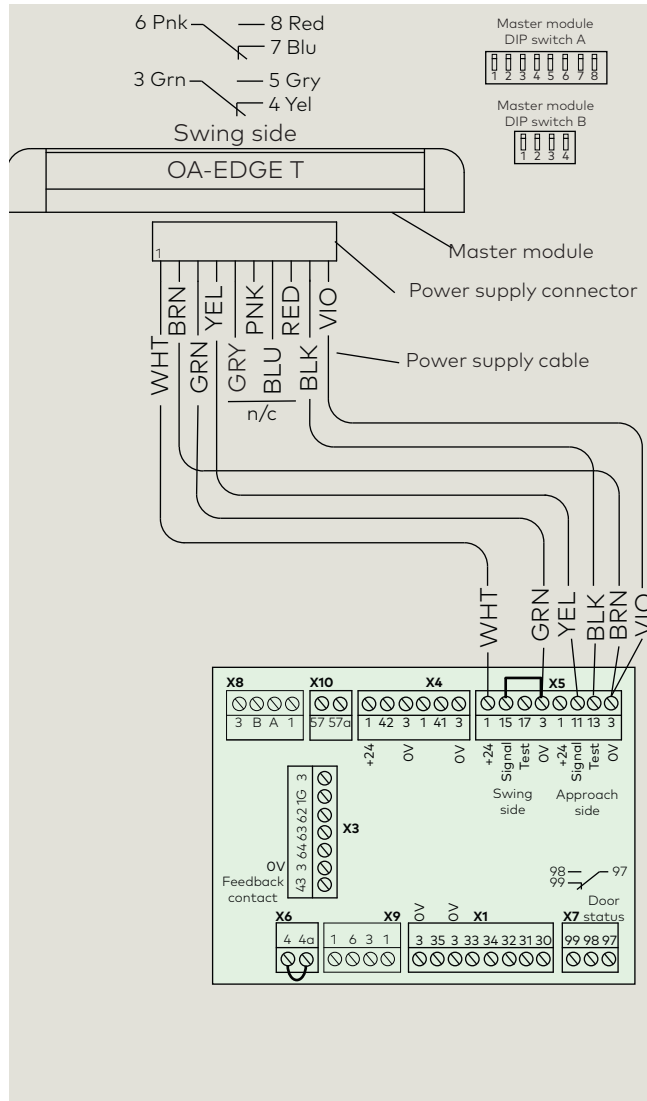

CAUTION

As shown, the Optex OA-Edge T does not comply with requirements of ANSI/BHMA 156.10, Para. 8.2.2.2, as a stand-alone presence sensor.

Fig. A7.3.2 One-way traffic

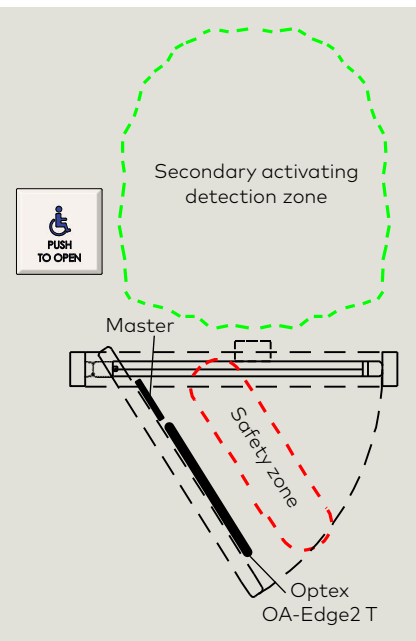

Table A7.3.1 Optex OA-Edge1T wiring

Bodyguard-T function	Pin	Wire color	ED100/ED250	
24V (+)	1	Wht	X5-1	+24
24V (-)	2	Brn	X5-3	0v
Safety Output 2	Approach side (reactivate)			
Relay common	3	Grn	X5-3	0V
Relay N.C.	4	Yel	X5-11	Presence approach side
Relay N.O.	5	Gry	n/c	
Safety Output 1	Swing side (stall)			
Relay common	6	Pnk	n/c	
Relay N.C.	7	Blu	n/c	
Relay N.O.	8	Red	n/c	
Test input (+)	9	Blk	X5-13	Approach side test
Test input (-)	9	Vio	X5-3	0V

A7.3.1 Install and commission Optex OA Edge T approach side sensor.

CAUTION

ED100/ED250 operator must have full learning cycle completed prior to sensor installation.

NOTICE

Confirm controller firmware is v2.1 or higher during learn cycle.

1. Connect wires from power supply cable to controller. Refer to Fig. A7.3.1 and Table A7.3.1.
2. Jumper in place X5-15 to 3.
3. Remove jumper from X5-11 to 3.

CAUTION

Refer to Optex OA-Edge1 T / OA-Edge2 T operation manual for sensor installation, settings, initialization and learning.

CAUTION

Parameter **hd** (Door Closer Mode) must be set to **"1" Automatic** for sensor setup and tuning!

4. Set Master module DIP switch A.

Master DIP switch A function	No.	Setting	Description
Non detection zone (A)	A1	On/Off	Non-detection zone; set in conjunction with DIP switch B as required to meet standards.
Frequency	A2	Off	For double doors; set each sensor's DIP switch differently.
Immunity	A3	Off	Set A3 to On when sensor operates by itself (ghosting).
Presence timer	A4 A5	On/Off	Set as required for sensor to function.
Future use	A6		
Test input	A7	On	Active low
Test input delay	A8	On	Test input delay time: 20 msec.

5. Set Master module DIP switch B.

Master DIP switch B Function	No.	Setting	Description
Non detection zone (B)	B1	On/Off	Non-detection zone; set in conjunction with DIP switch A as required to meet standards.
Area width	B2	On/Off	Set B2 to ON (2 spots) when narrow detection area is required.
Self monitoring mode	B3	On	Setting for USA.
Sensor side (output select)	B4	Off	Swing side Safety output 1, LED Solid Red (detection)

6. Set ED100/ED250 controller parameters for sensor initialization.

Parameter	Setting	Description
ST Safety Sensor Test	0	Sensor test off.

7. Initialize sensor per Optex operation manual.

8. ED100/ED250 parameter final settings:

Parameter	Setting	Description
ST Safety Sensor Test	5	Sensor test on approach side. Active-low

A8.1 Optex OA-FLEX T header mount presence sensor, single door, swing side, low energy application

Fig. A8.1.1 Optex Flex T sensor wiring

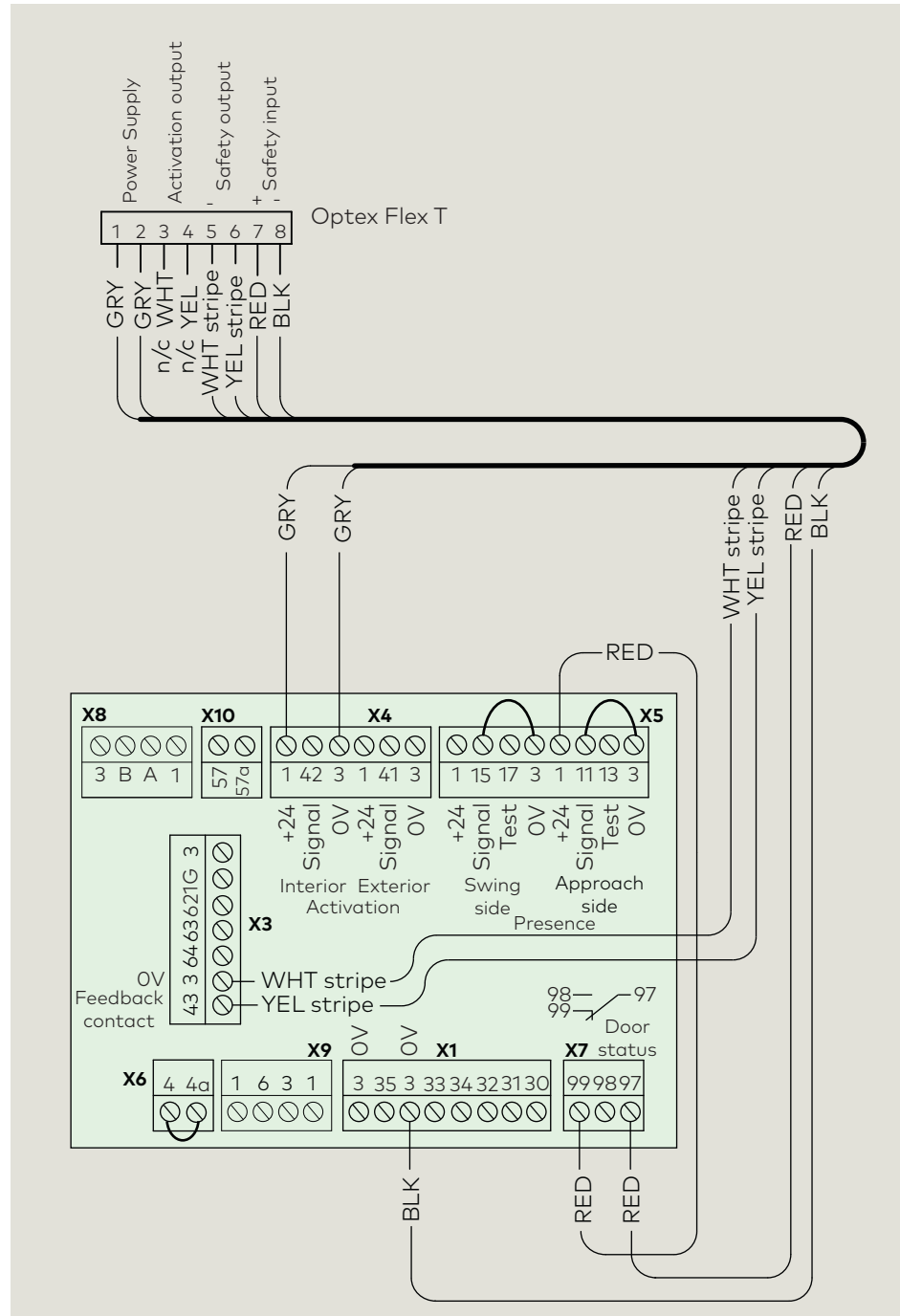

Fig. A8.1.2 Optex Premier T safety zone

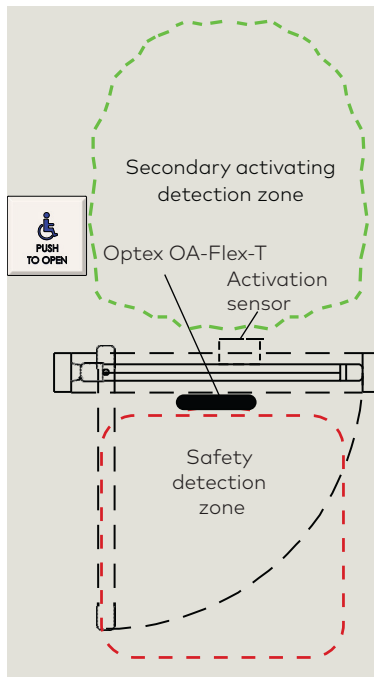

Table A8.1.1 Optex OA-FLEX T cable



Optex OA-FLEX T			ED100/ED250	
1	GRY	12 - 30Vdc	X4-1	+24 V
2	GRY	12 - 30Vdc	X4-3	0 V
3	WHT	Activation output	n/c	
4	YEL		n/c	
5	WHT stripe	Safety output	X3-3	0V
6	YEL stripe		X3-43	Feedback signal
7	RED	Test input +	X7-97	Door status
8	BLK	Test input -	X1-3	0 V

Table A8.1.2 Optex OA-FLEX T DIP switch

No.	Setting		Function
1			Sensitivity, set according to mounting height
2			Presence timer, 4 settings
3			
4	OFF		Frequency, when using more than one sensor close together, set frequency different for each sensor
5	OFF		
6			Row adjustment
7			
8	OFF		Immunity, set on when sensor operates by itself (ghosting)
9	ON	N.C.	Activation output to ED100/ED250
10	ON	N.C.	Safety output to ED100/ED250
11	ON	LOW	Safety input from ED100/ED250
12	ON		Presence area, presence timer is applied to all rows 1-6
13	n/a		
14	ON		Activation & Safety output will operate simultaneously regardless of detection area. Safety output will respond back with safety output when it receives safety input.
15			BLUEZONE (1st row)
16			Installation mode, set DIP switch ON to adjust 2nd row

A8.1.1 Install and commission Optex Premier-T sensor.

CAUTION

ED100/ED250 operator must have full learning cycle completed prior to sensor installation.

NOTICE

Confirm controller firmware is v2.1 or higher during learn cycle.

CAUTION

Refer to Optex Flex T installation manual for installation and setup.

1. Connect wires from connection cable to controller.
2. Jumpers in place 11 to 3 and 15 to 3.
4. Set ED100/ED250 controller parameters for sensor installation and setup.

Parameter	Setting	Description
ST Safety Sensor Test	8	Sensor test, overhead sensor type Bodyguard III or Premier T with monitoring input.



TIPS AND RECOMMENDATIONS

Door status relay **X7**, 97, 98, 99.
Sr status relay function parameter = **1** (factory setting).
 Status relay activated as soon as door reaches "closed" position.

